

Stasys 218

User Guide V1.1

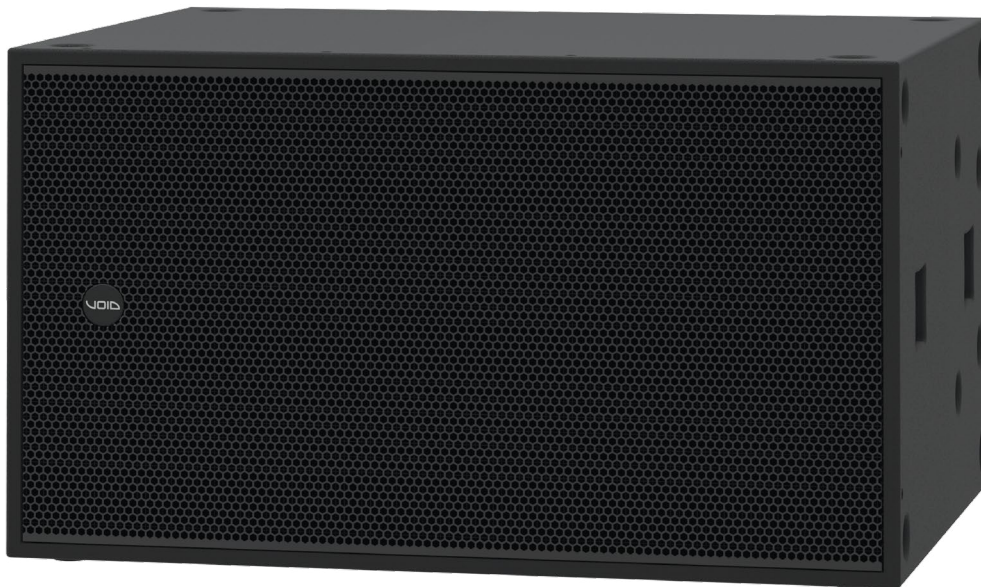

VOID

©2026 Void Acoustics Research Ltd.

Version 1.1

This user guide is subject to change without notice.
For the latest online version, visit: www.voidacoustics.com

Void Acoustics and the Void logo are registered trademarks of Void Acoustics Research Ltd. in the United Kingdom, USA and other countries; all other Void trademarks are the property of Void Acoustics Research Ltd.

Contents

1	Safety and regulations	4
1.1	Important safety instructions	4
1.2	Limitations	4
1.3	EC declaration of conformity	4
1.4	WEEE directive	4
1.5	Speaker Pole Mount Warning	4
2	Limited warranty	5
3	Unpacking and Checking	6
4	About	7
4.1	Welcome	7
4.2	Stasys 218 overview	7
4.3	Key features	7
4.4	Stasys 218 specifications	8
4.5	Stasys 218 dimensions	8
5	Cabling and wiring	9
5.1	Electrical safety	9
5.2	Cable consideration for fixed installations	9
5.3	Impedance graph	9
5.4	Stasys 218 wiring diagram	10
5.5	Bias V3/V9 4-pin locking connector wiring	10
5.6	Bias Q5 4-pin locking connector wiring	11
5.7	Amplifier loading guidelines	12
6	Operating modes	13
6.1	Manual handling guidelines	13
6.2	Typical modes	13
6.3	Cardioid modes	14
7	Adjustments	15
7.1	Wheel removal	15
7.2	Grille removal	16
8	Service	17
8.1	Return authorisation	17
8.2	Shipping and packing considerations	17
9	Appendix	18
9.1	Stasys 218 Architectural specification	18
9.2	Changelog	18

1 Safety and regulations

1.1 Important safety instructions



The lightning flash with an arrowhead symbol within an equilateral triangle is intended to alert the user to the presence of uninsulated "dangerous voltage" within the product's enclosure that may be of sufficient magnitude to constitute a risk of electric shock to persons.



The exclamation point within an equilateral triangle is intended to alert the user of the presence of important operating and maintenance (servicing) instructions in the literature accompanying the appliance.

Safety instructions - read this first

1. Read these instructions.
2. Keep these instructions.
3. Heed all warnings.
4. Follow all instructions.
5. Do not use this apparatus near water.
6. Clean only with a dry cloth.
7. Do not block any ventilation openings. Install in accordance with the manufacturer's instructions.
8. Do not install near any heat source such as radiators, heat registers, stoves, or other such apparatus that produce heat.
9. Do not defeat the safety purpose of the grounding-type plug. A grounding type plug has two blades and a third grounding prong. The third prong is provided for your safety. If the provided plug does not fit into your outlet, consult an electrician for replacement of the obsolete outlet.
10. Protect power cords from being walked on or pinched particularly at plugs, convenience receptacles, and the point where they exit the apparatus.
11. Only use attachments and accessories specified by Void Acoustics.
12. Only use with the cart, stand, tripod, bracket, or table specified by the manufacturer, or sold with the apparatus. When a cart is used, use caution when moving the cart/apparatus combination to avoid injury from tip-over.
13. Unplug the apparatus during lightning storms or when unused for long periods of time.
14. Refer all servicing to qualified service personnel. Servicing is required when the apparatus has been damaged in any way, such as when the power-supply cord or plug is damaged, liquid has been spilled or objects have fallen into the apparatus, the apparatus has been exposed to rain or moisture, does not operate normally, or has been dropped.
15. Since the mains power supply cord attachment plug is used to disconnect the device, the plug should always be easily accessible.
16. Void loudspeakers can produce sound levels capable of causing permanent hearing damage from prolonged exposure. The higher the sound level, the less exposure needed to cause such damage. Avoid prolonged exposure to the high sound levels from the loudspeaker.

1.2 Limitations

This guide is provided to help familiarise the user with the loudspeaker system and its accessories. It is not intended to provide comprehensive electrical, fire, mechanical and noise training and is not a substitute for industry-approved training. Nor does this guide absolve the user of their obligation to comply with all relevant safety legislation and codes of practice. While every care has been taken in creating this guide, safety is user-dependent and Void Acoustics Research Ltd cannot guarantee complete safety whenever the system is rigged and operated.

1.3 EC declaration of conformity

For EC Declaration of Conformity please go to:

www.voidacoustics.com/eu-declaration-loudspeakers

1.4 UKCA marking

For details of the UKCA marking go to:

www.voidacoustics.com/uk-declaration-loudspeakers

1.5 Warranty statement

For warranty statement go to:

<https://voidacoustics.com/terms-conditions/>

1.6 WEEE directive

If the time arises to throw away your product, please recycle all the components possible.



This symbol indicates that when the end-user wishes to discard this product, it must be sent to separate collection facilities for recovery and recycling. By separating this product from other household-type waste, the volume of waste sent to incinerators or land-fills will be reduced and natural resources will thus be conserved.

The Waste Electrical and Electronic Equipment Directive (WEEE Directive) aims to minimise the impact of electrical and electronic goods on the environment. Void Acoustics Research Ltd complies with the Directive 2002/96/EC and 2003/108/EC of the European Parliament on waste electrical and electronic equipment (WEEE) in order to reduce the amount of WEEE that is being disposed of in land-fill sites. All of our products are marked with the WEEE symbol; this indicates that this product must NOT be disposed of with other waste. Instead it is the user's responsibility to dispose of their waste electrical and electronic equipment by handing it over to an approved reprocessor, or by returning it to Void Acoustics Research Ltd for reprocessing. For more information about where you can send your waste equipment for recycling, please contact Void Acoustics Research Ltd or one of your local distributors.

1.7 Speaker Pole Mount Warning

M20 top hats are designed to support a maximum centric load of 35



kgs and not suitable for mounting heavier products such as the Air Motion or Tri Motion. Always place the base of the subwoofer on a flat and stable surface. The stability of the system depends on the height of the pole, and the size and weight of the speakers. It is the responsibility of the user to ensure the assembled system is secure and stable. Misuse could lead to injury or equipment damage. Always make sure that the M20 pole is fully fastened into the threaded top hat, damaged is likely to occur if not secured tightly.



2 Limited warranty

Limited warranty

The warranty

For a period of three (3) years from the date of delivery to the original purchaser (as shown on the original invoice or sales receipt; a copy of this may be required as proof of warranty dates), Void Acoustics Research Ltd (hereinafter "Void") warrants to the Original Owner (person or company who originally purchased the product brand new from either Void or a Void Authorised Dealer/Distributor) of each new Stasys Series product (provided it was purchased at an Authorised Void Dealer) that it is free of defects in materials and workmanship and that each product will meet or exceed all factory published specifications for each respective model. Void agrees to repair or replace (at its discretion) all defective parts at no charge for labour or materials; subject to following provisions:

Warranty violations

Void shall take no responsibility for repair or replacement as specified under this warranty, if the damaged product has been subject to misuse, accident, neglect or failure to comply with normal maintenance procedures; or if the serial number has been defaced, altered or removed. Nor will Void accept responsibility for, or resulting from, improper alterations or unauthorised parts or repairs. This warranty does not cover any damage to speakers or any other consequential damage resulting from breach of any written or implied warranty.

Void warranty provisions

Void will remedy any defect, regardless of the reason for failure (except as excluded) by repair, or replacement. Void will remedy the defect and ship the product within a reasonable time after receipt of the defective product at a Void Authorised Service Centre.

To obtain warranty service

If a Void product requires service, the Owner must contact Void or an Authorised Void Service Centre to receive an R.A.N. (Return Authorisation Number) and instructions on how to return the product to the Void Authorised Service Centre, or to Void.

Void (or its Authorised Service Centre) will initiate corrective repairs upon receipt of the returned product. Please save the original carton and all the packing materials in case shipping is required. All products being returned to the factory or service centre for repairs must be shipped prepaid.

If the repairs made by Void or the Void Authorised Service Centre are not satisfactory, the Owner is instructed to give written notice to Void. If the defect or malfunction remains after a reasonable number of attempts by Void to remedy the defect or malfunction, the Original Owner shall then have the option to elect either a refund or replacement of said Void product free of charge. The refund shall be an amount equal to but not greater than the actual purchase price, not including any taxes, interest, insurance, closing costs and other finance charges (minus reasonable depreciation on the product). If a refund is necessary, the Original Owner must make the defective or malfunctioning product available to Void free and clear of all liens or other restrictions.

Equipment modifications

Technical and design specifications are subject to change without notice.

Void reserves the right to modify or change equipment (in whole or part) at any time prior to delivery thereof, in order to include therein electrical or mechanical improvements deemed appropriate by Void, but without incurring any liability to modify or change any equipment previously delivered, or to supply new equipment in accordance with any earlier specifications.

Disclaimer of consequential and incidental damages

You, the Original Owner, are not entitled to recover from Void any incidental damages resulting from any defect in the Void product.

This includes any damage to another product or products resulting from such a defect.

Warranty alterations

No person has the authority to enlarge, amend, or modify this Warranty. This Warranty is not extended by the length of time which the Original Owner is deprived of the use of product. Repairs and replacement parts provided pursuant to the Warranty shall carry only the non-expired portion of the Warranty.

This Statement of Warranty supersedes all others contained in this user guide.

3 Unpacking and checking

All Void Acoustics products are carefully manufactured and thoroughly tested before being despatched. Your dealer will ensure that your Void products are in pristine condition before being forwarded to you but mistakes and accidents can happen.

Before signing for your delivery:

- Inspect your shipment for any signs of contamination, abuse or transit damage as soon as you receive it
- Check your Void Acoustics delivery fully against your order
- If your shipment is incomplete or any of its contents are found to be damaged; inform the shipping company and inform your dealer.

When you are removing your Stasys 218 loudspeaker from its original packaging:

- Stasys 218 loudspeakers come packaged in a lid and base carton that has a protective sleeve around it; avoid using sharp implements to remove the cardboard to protect the finish
- If you need to place the loudspeaker on a flat surface make sure it is free from debris
- When you have removed the Stasys 218 loudspeaker from the packaging inspect it to ensure there is no damage and keep all original packaging in case it needs to be returned for any reason.

See section 2 for warranty conditions and see section 8 if your product needs servicing.

4 About

4.1 Welcome

Many thanks for purchasing this Void Acoustics Stasys 218. We truly appreciate your support. At Void, we design, manufacture and distribute advanced professional audio systems for the installed and live sound market sectors. Like all Void products, our highly skilled and experienced engineers have successfully combined pioneering technologies with ground-breaking design aesthetics, to bring you superior sound quality and visual innovation. In buying this product, you are now part of the Void family and we hope using it brings you years of satisfaction. This guide will help you both use this product safely and ensure it performs to its full capability.

4.2 Stasys 218 overview

The Stasys 218 is a double 18 inch, reflex-loaded, low frequency enclosure built around traditional principles but designed with Stasys philosophy and attention to detail. Resonance mapping has influenced the optimal brace positioning and minimal destructive nodal conditions, creating a superior structure with minimum mass, the least possible cabinet colouration, and vastly increased output. Marrying a technologically advanced enclosure with a powerful transducer, results in a phenomenal package with state-of-the-art performance.

4.3 Key features

- Dual 18 inch neodymium low-frequency drivers with 4 inch voice coil
- 2400 W AES power handling
- Optimally damped, minimal mass cabinet to reduce colouration
- Dual 4-pin locking connector with link-through for quick and easy set up
- Optional castors and protective covers
- 18 mm birch plywood construction
- Black textured 'TourCoat' polyurea finish
- Available as standard in black with a black grille. White finishes and custom RAL finishes for the grille are available upon request

4 About

4.4 Stasys 218 specifications

Frequency Response ¹	34 Hz - Preset dependent
Maximum Output ²	134 dB cont, 140 dB peak
Nominal Dispersion	Array dependent
Sensitivity ²	101 dB 1W/1m
Driver Configuration	2 x 18" LF
Power Handling	2400 W AES
Nominal Impedance	4 Ω
Suggested Minimum Amplifier	Bias Q5
Weight	86 kg (189.6 lbs)
Connections	2 x 4-pin locking connector
Enclosure	18 mm birch plywood
Finish	Textured 'TourCoat' polyurea
Mounting	M20 top hat included
Height	586 mm (23.1")
Width	1020 mm (40.2")
Depth	775 mm (30.5")

¹ -10 dB IEC 60268-5 ² Calculated ³ Measured in half space

4.5 Stasys 218 dimensions

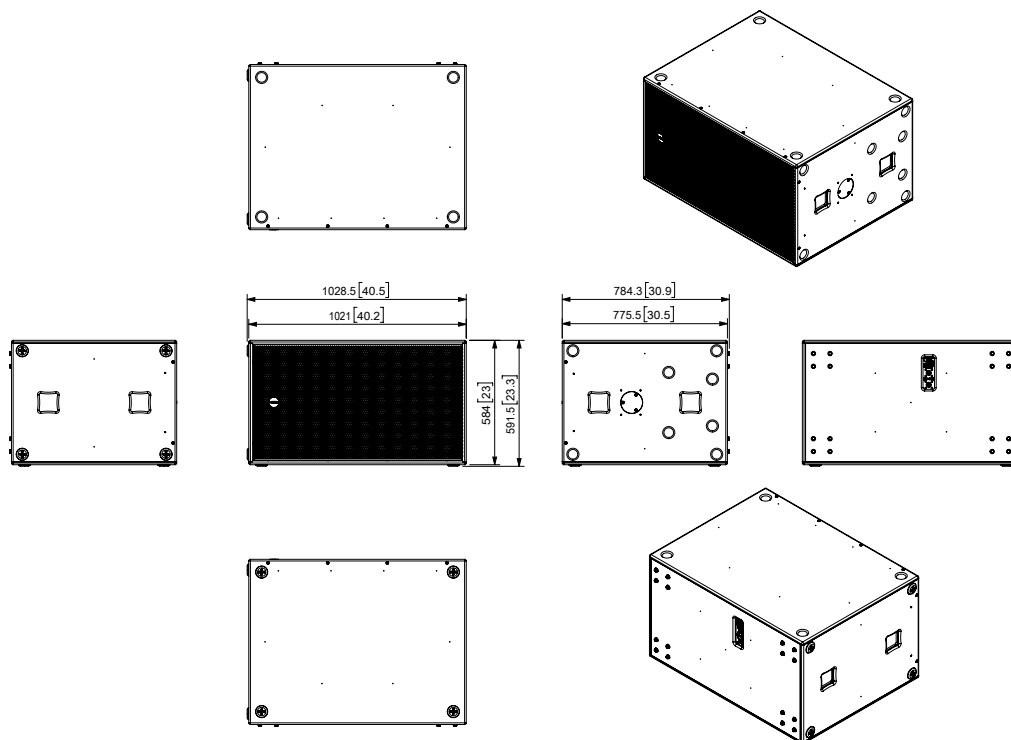

Figure 4.1: Dimensions

5 Cabling and wiring

5.1 Electrical safety



To avoid electrical hazards please note the following:

- Do not access the inside of any electrical equipment. Refer servicing to Void-approved service agents.

5.2 Cable considerations for fixed installations

We recommend specifying installation-grade Low Smoke Zero Halogen (LSZH) cables for permanent installations. The cables should use Oxygen Free Copper (OFC) of grade C11000 or above. Cables for permanent installations should be compliant with the following standards:

- IEC 60332.1 Fire retardancy of a single cable
- IEC 60332.3C Fire retardancy of bunched cables
- IEC 60754.1 Amount of Halogen Gas Emissions
- IEC 60754.2 Degree of acidity of released gases
- IEC 61034.2 Measurement of smoke density.

We suggest using the following maximum copper cable lengths to keep level losses below 0.6 dB.

Metric mm ²	Imperial AWG	4 Ω load	2 Ω load
2.50 mm ²	13 AWG	18 m	9 m
4.00 mm ²	11 AWG	30 m	15 m

5.3 Impedance graph

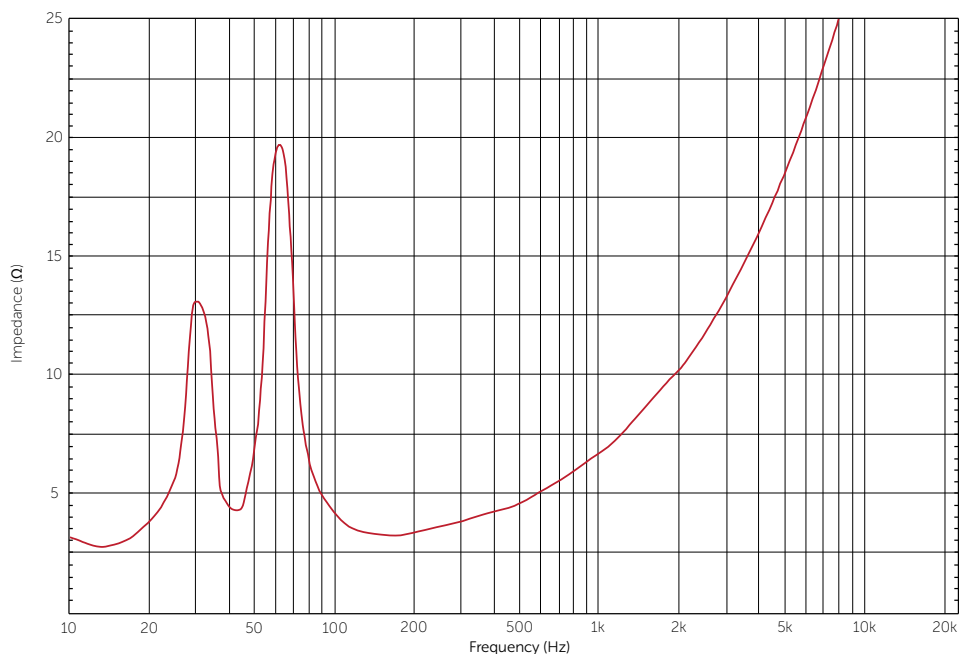

Figure 5.1: Impedance graph

5 Cabling and wiring

5.4 Stasys 218 wiring diagram

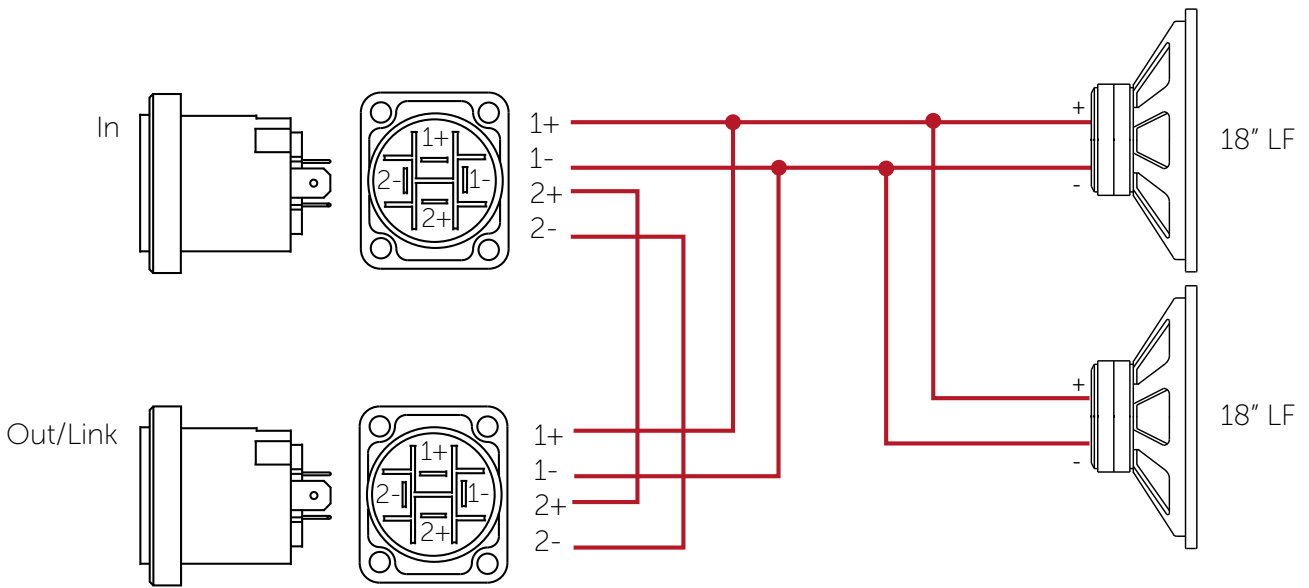

Figure 5.2: Wiring diagram

	4-pin locking connector pins 1+/1-	4-pin locking connector pins 2+/2-
In	LF (2 x 18")	n/c
Out	Link/out	n/c

5.5 Bias V3/V9 4-pin locking connector wiring

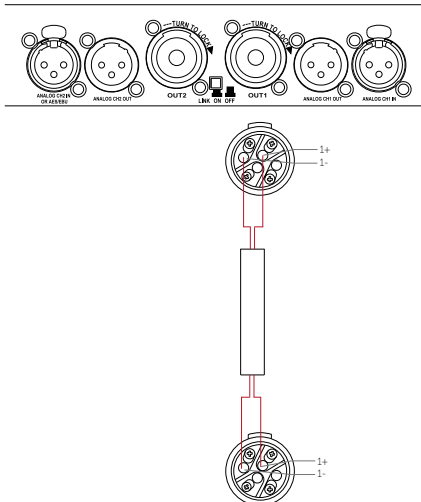

Figure 5.3: Bias V3

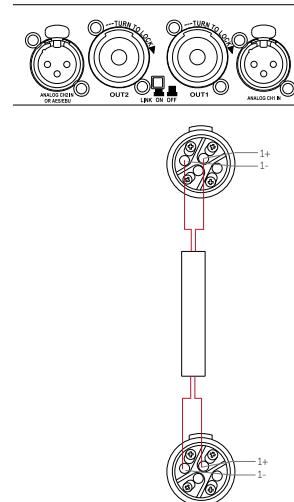

Figure 5.4: Bias V9

Bias V3/V9	Output 1 or 2
Output	LF (2 x 18")
Max parallel units	2 (2 Ω load to amplifier)

5 Cabling and wiring

5.6 Bias Q5 4-pin locking connector wiring

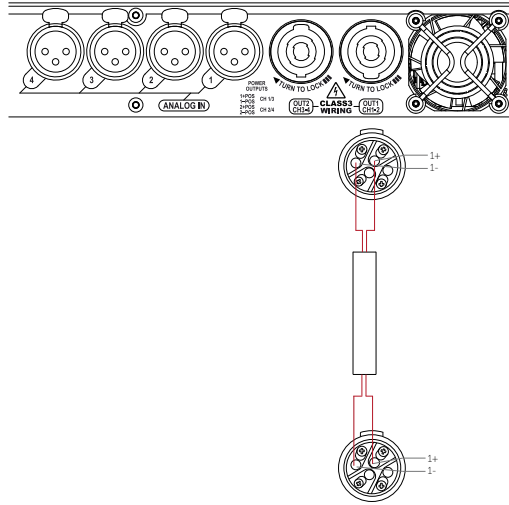

Figure 5.5: Bias Q5

Bias Q5	Output 1
Output	LF (2 x 18")
Max parallel units	2 (2 Ω load to amplifier)

5 Cabling and wiring

5.7 Amplifier loading guidelines

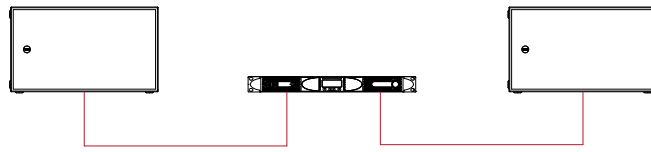

Figure 5.6: 2 x Stasys 218: 4 Ω per channel / 1 amplifier

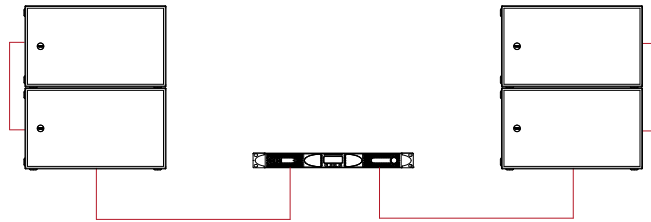

Figure 5.7: 4 x Stasys 218: 2 Ω per channel / 1 amplifier

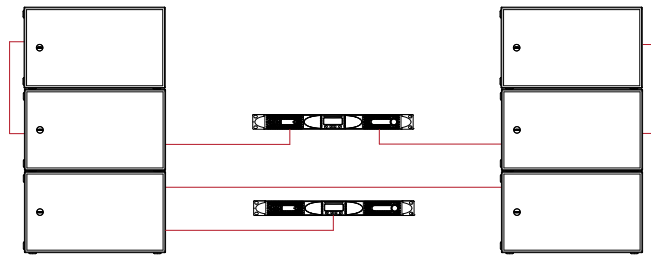

Figure 5.8: 6 x Stasys 218: 2 Ω per channel / 2 amplifier

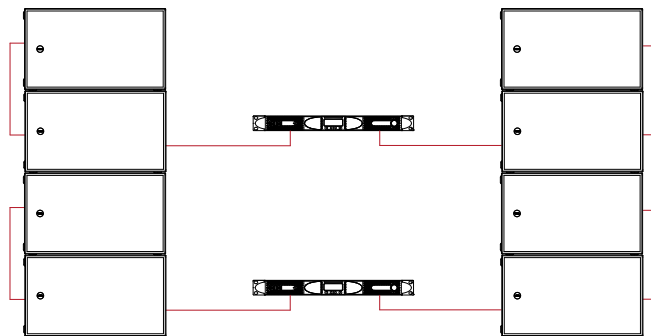

Figure 5.9: 8 x Stasys 218: 2 Ω per channel / 2 amplifier

Ensure all amplifier channels are loaded equally. Limiters engage correctly. Cabinets acoustic principles are the same.

6 Operating modes

6.1 Manual handling guidelines



To avoid manual handling hazards please note the following:

- Be sure to secure any loudspeaker systems following correct local procedures/guideline
- Low frequency enclosures are heavy and require a minimum of two people to move; for more information on safe handling consult INDG143.

6.2 Typical modes

Although the modes of arrangement shown here are typical operating modes for low frequency enclosures, the Stasys 218 system's symmetrical design lends itself to wide range of configurations. Simple planer arrays and stacks to directional and steerable arrays are possible given suitable electronics and presets. Contact your local Void distributor/dealer for more information.

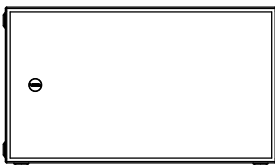

Single

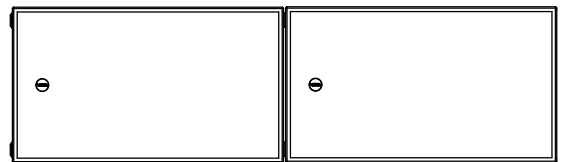

Horizontal

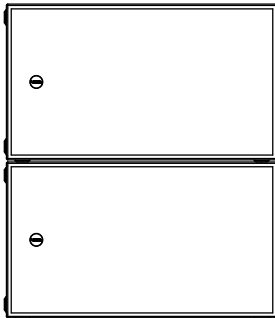

Vertical

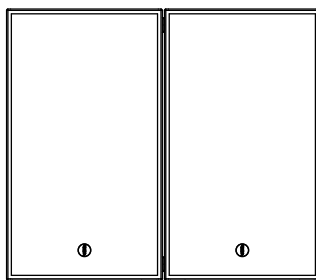

On-end

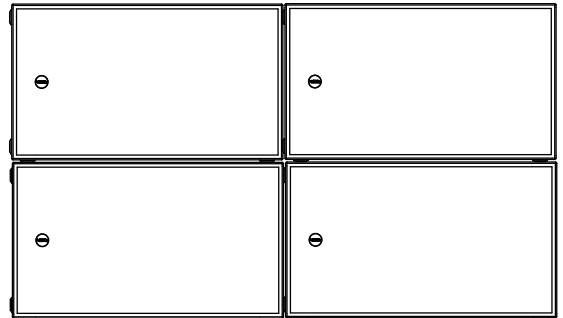

Block

Figure 6.1: Typical mode layouts

6 Operating modes

6.3 Cardioid modes

As low frequency enclosures are omnidirectional, rear projection can cause a range of difficulties. If there is a wall behind the array, the sound wave can reflect off the surface and may cause cancellation in front if it arrives out of phase with the wave from the source. Another problem may occur during performances where an array is deployed in front of the stage, possibly creating a maximum sound pressure level that makes it difficult for some performers. Adopting a cardioid configuration can overcome this problem as it creates a heart shaped horizontal dissipation reducing the rear projection. A variety of cardioid configurations are available, as shown below. For other layouts or more information, please contact your local Void distributor/dealer.

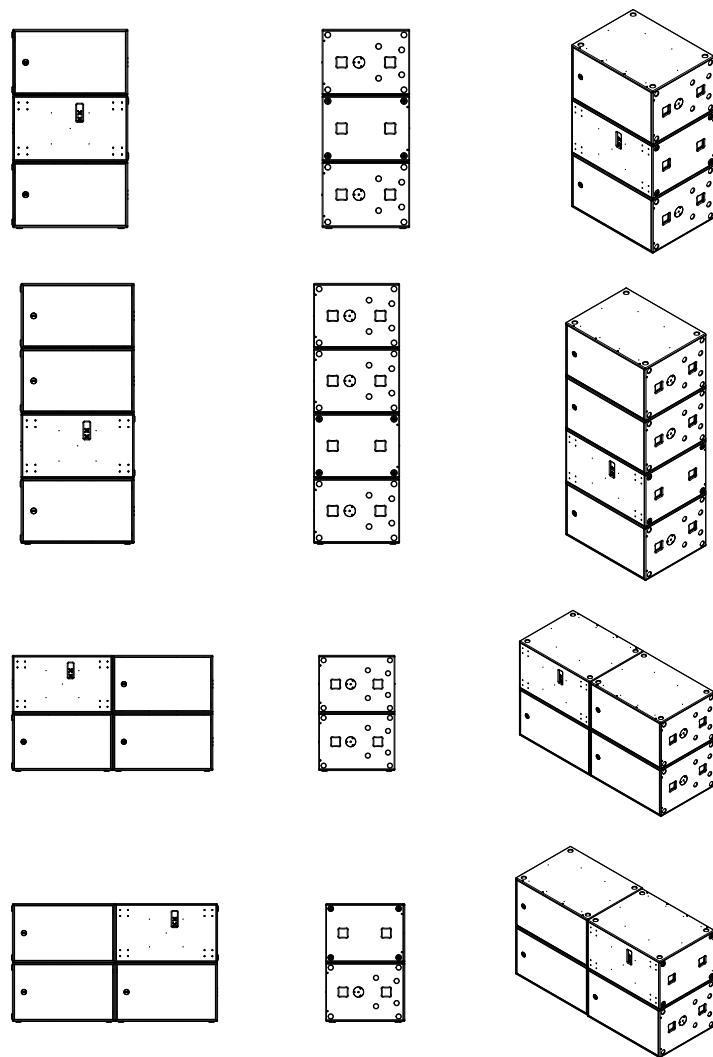

Figure 6.2: Cardioid mode layouts

7 Adjustments

To avoid damage when making adjustments please note the following:



- Removing the grille can cause debris to collect within the enclosure, take care to remove anything that may have collected internally
- Do not use impact tools.

7.1 Wheel removal

Step 1:

Remove all four M6 bolts with a 13 mm spanner/wrench.

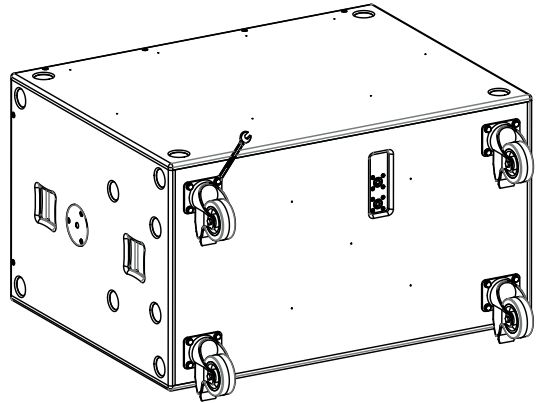

Figure 7.1: Bolt removal

Step 2:

Remove/add the wheels and keep in a safe place. Repeat the process for the other three wheels.

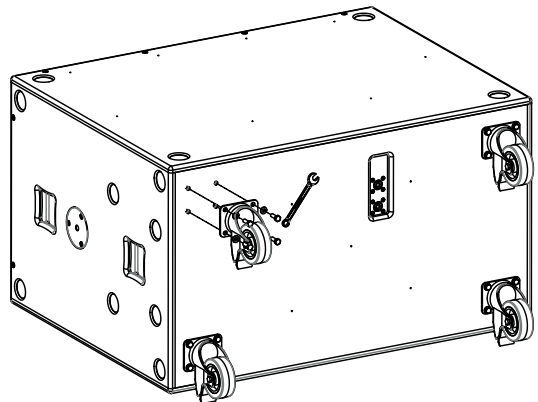

Figure 7.2: Wheel removal

Step 3:

Replace the M8 bolts by hand until finger tight before using hand tools.



Note: Replacing bolts is of particular importance as without them there can be air leakage and detuning.

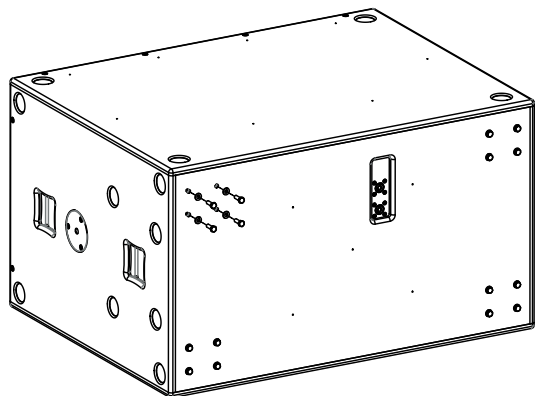

Figure 7.3: Bolt tightening

7 Adjustments

7.2 Grille removal

Step 1:

Undo all twelve M6 tab bolts using a 4 mm Allen key, take care NOT to remove the tab bolts as they may become lost within the enclosure.

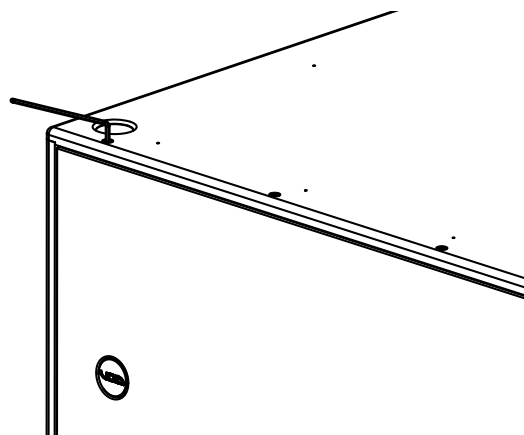

Figure 7.4: Bolt removal

Step 2:

Remove grille.

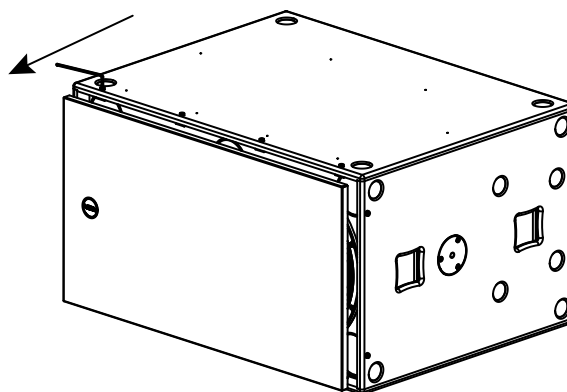

Figure 7.5: Grille removal

Step 3:

Replace the M6 bolts by hand until finger tight before using hand tools.

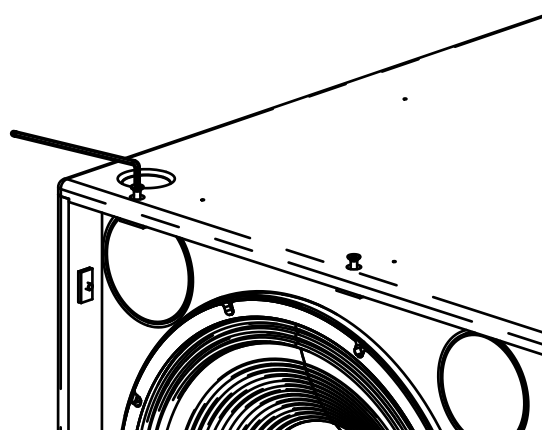

Figure 7.6: Bolt replacement

8 Service

Void Stasys 218 loudspeakers should only be serviced by a fully-trained technician.



No user serviceable parts inside. Refer servicing to your dealer.

8.1 Return authorisation

Before returning your faulty product for repair, please remember to get an R.A.N. (Return Authorisation Number) from the Void dealer who supplied the system to you. Your dealer will handle the necessary paperwork and repair. Failure to go through this return authorisation procedure could delay the repair of your product.

Note that your dealer will need to see a copy of your sales receipt as proof of purchase so please have this to hand when applying for return authorisation.

8.2 Shipping and packing considerations

- When sending a Void Stasys 218 loudspeaker to an authorised service centre, please write a detailed description of the fault and list any other equipment used in conjunction with the faulty product.
- Accessories will not be required. Do not send the instruction manual, cables or any other hardware unless your dealer asks you to.
- Pack your unit in the original factory packaging if possible. Include a note of the fault description with the product. Do not send it separately.
- Ensure safe transportation of your unit to the authorised service centre.

9 Appendix

9.1 Stasys 218 Architectural specification

The loudspeaker system shall be of the sub bass type consisting of two high power 18" (457.2 mm) direct radiating, reflex loaded, low frequency (LF) transducers in a rectangular enclosure.

The low frequency transducer shall be constructed on a cast aluminium frame, with a treated paper cone, long excursion 101.6 mm (4") voice coil, wound with copper wires on a high quality voice coil former and a neodymium magnet for high power handling and long-term reliability.

Performance specifications for a typical production unit shall be as follows: the usable bandwidth shall be 34 Hz to Preset dependent (-10 dB IEC 60268-5) and have a maximum on axis SPL of 134 dB continuous (140 dB peak) measured at 1 m using IEC265-5 pink noise. Power handling shall be 2400 W AES at a rated impedance of 4 Ω with pressure sensitivity of 101 dB measured at 1W/1m. The system shall be powered by its own dedicated power amplification module with DSP management. The wiring connection shall be via two 4-pin locking connector (one for input and one for loop-out to another speaker), to allow for pre-wiring of the connector before installation.

The enclosure shall be constructed from a 18 mm multi-laminate birch plywood finished in a textured polyurea and shall contain fixture points for a pressed weather-resistant, powder coated steel grille with foam filter to protect the low frequency transducer. The cabinet shall have four handles (two per side) for efficient manual handling. External dimensions of (H) 586 mm x (W) 1020 mm x (D) 775 mm (23.1" x 40.2" x 30.5"). Weight shall be 86 kg (189.6 lbs).

The loudspeaker system shall be a Void Acoustics Stasys 218.

9.2 Changelog

Document Version	Notes	Valid for S.N
UG11089-1.1	Updated specs to IEC 60268-5	S218XXX - Current

North America

Void Acoustics North America
+1 (630) 686-6616
sales.usa@voidacoustics.com

Head Office

Void Acoustics Research Ltd
Unit L, The Fulcrum
Vantage Way
Poole
Dorset
BH12 4NU
England

+44 (0) 1202 666 006
hello@voidacoustics.com

Registered in England & Wales No. 07533536

www.voidacoustics.com

