



VOID

Air 12

User Guide

Contents

1	Safety and Regulations	1
1.1	Important Safety Instructions	1
1.2	Limitations	1
1.3	EC Declaration of Conformity	1
1.4	UKCA Conformity	1
1.5	Warranty Statement	1
1.6	WEEE Directive	1
2	Unpacking and Checking	2
3	About	3
3.1	Welcome	3
3.2	Air 12 Overview	3
3.3	Key Features	3
3.4	Air 12 Specifications	4
3.5	Air 12 Dimensions	5
4	Cable and Wiring	6
4.1	Electrical Safety	6
4.2	Cable Considerations for Fixed Installations	6
4.3	Air 12 Wiring Diagram	6
4.4	Air 12 Gland Connector Wiring	7
4.5	Bias D1+/Q1+/Q1.5+/Q2+ Phoenix Wiring	7
4.6	Bias Q3/Q5 4-pin locking connector Wiring	8
4.7	Max Parallel Units	8
5	Mounting	9
5.1	Installation Safety	9
5.2	Air 12 Tilt Bracket Assembly	10
5.3	Air 12 Tilt Bracket Adjustability	11
5.4	Air 12 Flush-Mount Bracket Assembly	12

5.5	T80XL Wall Bracket Assembly	13
5.6	T80XL Wall Bracket Adjustability	14
5.7	T80 Corner Bracket Assembly	15
5.8	T80 Corner Bracket Adjustability	16
5.9	T80 Ceiling Bracket Assembly	17
5.10	T80 Ceiling Bracket Adjustability	18
5.11	T80 Pole Bracket Assembly	19
5.12	T80 Pole Bracket Adjustability	20
6	Maintenance	21
6.1	Cleaning and Maintenance	21
7	Service	22
7.1	Return Authorisation	22
7.2	Shipping and Packing Considerations	22
8	Appendix	23
8.1	Architectural Specification	23
8.2	Changelog	23

1.0 Safety and Regulations



1.1 Important safety instructions



The lightning flash with an arrowhead symbol within an equilateral triangle is intended to alert the user to the presence of uninsulated “dangerous voltage” within the product’s enclosure that may be of sufficient magnitude to constitute a risk of electric shock to persons.



The exclamation point within an equilateral triangle is intended to alert the user of the presence of important operating and maintenance (servicing) instructions in the literature accompanying the appliance.

Safety instructions - read this first

1. Read these instructions.
2. Keep these instructions.
3. Heed all warnings.
4. Follow all instructions.
5. Do not use this apparatus near water.
6. Clean only with a dry cloth.
7. Do not block any ventilation openings. Install in accordance with the manufacturer’s instructions.
8. Do not install near any heat source such as radiators, heat registers, stoves, or other such apparatus that produce heat.
9. Do not defeat the safety purpose of the grounding-type plug. A grounding-type plug has two blades and a third grounding prong. The third prong is provided for your safety. If the provided plug does not fit into your outlet, consult an electrician for replacement of the obsolete outlet.
10. Protect power cords from being walked on or pinched particularly at plugs, convenience receptacles, and the point where they exit the apparatus.
11. Only use attachments and accessories specified by Void Acoustics.
12. Only use with the cart, stand, tripod, bracket, or table specified by the manufacturer, or sold with the apparatus. When a cart is used, use caution when moving the cart/apparatus combination to avoid injury from tip-over.
13. Unplug the apparatus during lightning storms or when unused for long periods of time.
14. Refer all servicing to qualified service personnel. Servicing is required when the apparatus has been damaged in any way, such as when the power-supply cord or plug is damaged, liquid has been spilled or objects have fallen into the apparatus, the apparatus has been exposed to rain or moisture, does not operate normally, or has been dropped.
15. Since the mains power supply cord attachment plug is used to disconnect the device, the plug should always be easily accessible.
16. Void loudspeakers can produce sound levels capable of causing permanent hearing damage from prolonged exposure. The higher the sound level, the less exposure needed to cause such damage. Avoid prolonged exposure to the high sound levels from the loudspeaker.
17. Installation must be carried out by qualified personnel only.

1.2 Limitations

This guide is provided to help familiarise the user with the loudspeaker system and its accessories. It is not intended to provide comprehensive electrical, fire, mechanical and noise training and is not a substitute for industry-approved training. Nor does this guide absolve the user of their obligation to comply with all relevant safety legislation and codes of practice. While every care has been taken in creating this guide, safety is user-dependent and Void Acoustics Research Ltd cannot guarantee complete safety whenever the system is rigged and operated.

1.3 EC declaration of conformity

For EC Declaration of Conformity please go to:

voidacoustics.com/eu-declaration-loudspeakers

1.4 UKCA marking

For details of the UKCA marking go to:

voidacoustics.com/uk-declaration-loudspeakers

1.5 Warranty statement

For warranty statement go to:

voidacoustics.com/terms-conditions/

1.6 WEEE directive

If the time arises to throw away your product, please recycle all the components possible.



This symbol indicates that when the end-user wishes to discard this product, it must be sent to separate collection facilities for recovery and recycling. By separating this product from other household-type waste, the volume of waste sent to incinerators or land-fills will be reduced and natural resources will thus be conserved.

The Waste Electrical and Electronic Equipment Directive (WEEE Directive) aims to minimise the impact of electrical and electronic goods on the environment. Void Acoustics Research Ltd complies with the Directive 2002/96/EC and 2003/108/EC of the European Parliament on waste electrical finance the cost of treatment and recovery of electronic equipment (WEEE) in order to reduce the amount of WEEE that is being disposed of in land-fill sites. All of our products are marked with the WEEE symbol; this indicates that this product must NOT be disposed of with other waste. Instead it is the user’s responsibility to dispose of their waste electrical and electronic equipment by handing it over to an approved reprocessor, or by returning it to Void Acoustics Research Ltd for reprocessing. For more information about where you can send your waste equipment for recycling, please contact Void Acoustics Research Ltd or one of your local distributors.

2.0 Unpacking and Checking

All Void Acoustics products are carefully manufactured and thoroughly tested before being despatched. Your dealer will ensure that your Void products are in pristine condition before being forwarded to you, but mistakes and accidents can happen.

Before signing for your delivery:

- Inspect your shipment for any signs of contamination, abuse or transit damage as soon as you receive it.
- Check your Void Acoustics delivery fully against your order.
- If your shipment is incomplete or any of its contents are found to be damaged, inform the shipping company and your dealer.

When you are removing your Air 12 loudspeaker from its original packaging:

- Air 12 loudspeakers come double-boxed and stapled shut; take care when unboxing by removing the staples to avoid injury or damage to the loudspeaker.
- Lift the loudspeaker out of the box from the outer rim ensuring pressure isn't put on the grille of the Air 12.
- If you need to place the loudspeaker on a flat surface ensure you use a soft, non-abrasive lint-free product to protect the finish.
- When you have removed the Air 12 loudspeaker from the packaging inspect it to ensure there is no damage and keep all original packaging in case it needs to be returned for any reason.

3.0 About

3.1 Welcome

Many thanks for purchasing this Void Acoustics Air Series loudspeaker. We truly appreciate your support. At Void, we design, manufacture and distribute advanced professional audio systems for the installed and live sound market sectors. Like all Void products, our highly skilled and experienced engineers have successfully combined pioneering technologies with ground-breaking design aesthetics, to bring you superior sound quality and visual innovation. In buying this product, you are now part of the Void family and we hope using it brings you years of satisfaction. This guide will help you both use this product safely and ensure it performs to its full capability.

3.2 Air 12 Overview

The Air 12 is a compact, high-output coaxial loudspeaker that combines exceptional performance with a unique and visually impactful design.

Featuring a 400 W AES power-handling coaxial driver, delivering an exceptionally uniform radiation pattern for precise sound coverage and unmatched audio clarity. The Air 12 is constructed from a low-resonance fibreglass composite, with optimised internal geometry to minimise cabinet distortions.

Designed for versatility, the Air 12 comes supplied with a low-profile flush-mount bracket, with optional tilt and swivel bracket and T80 accessory compatibility. Air 12 carries an IP-54 rating and features a new hydrophobic membrane for enhanced ingress protection. Combined with ingress-proof rear connectors for enhanced durability when installed outside.

Available in Void Red, Black, and White finishes, with custom RAL and KROME options upon request.

3.3 Key Features

- Visually striking, sculpted design in a low-resonance fibreglass enclosure
- Compact two-way reflex system
- High-performance coaxial driver with optimised neodymium motor design
- Controlled 80° x 80° dispersion for consistent coverage
- 400 W AES power handling
- Weather-resistant input glands with Phoenix connector and link-through functionality
- Weather protected with an IP-54 rating
- Hydrophobic membrane for enhanced ingress protection
- T80-style rear fixing points compatibility with a wide range of mounting options
- Supplied with a low-profile flush-mount bracket, positioning the Air 12 at a fixed 30° declining angle
- Optional tilt and swivel bracket
- Available as standard in red with a black grille, black with a black grille, and white with a white grille. Custom RAL and KROME finishes are available upon request.

3.4 Air 12 Specifications

Frequency Response¹	75 Hz - 20 kHz
Maximum Output²	124 dB cont, 130 dB peak
Nominal Dispersion	80°H x 80°V
Sensitivity³	98 dB 1W/1m
Driver configuration	1 x 12" LF, 1 x 1" Coaxial
Power Handling	400 W AES
Nominal Impedance	8 Ω
Suggested Minimum Amplifier	Bias Q1.5+
Weight	12.5 kg (27.6 lbs)
IP rating	IP-54
Connections	Phoenix connector with link out
Enclosure	Fibreglass Composite
Finish	Smooth cellulose
Mounting	Low profile flush-mount bracket included, ype 80 plate.
Grille	Perforated aluminium with foam filter and hydrophobic membrane
Colour	Void red, black and white finishes, with RAL and KROME options upon request
Height	424mm (17 inch)
Width	367mm (14 inch)
Depth	329mm (13 inch)

1 -10 dB IEC 60268-5 2 Calculated 3 Measured in half space

3.5 Air 12 dimensions

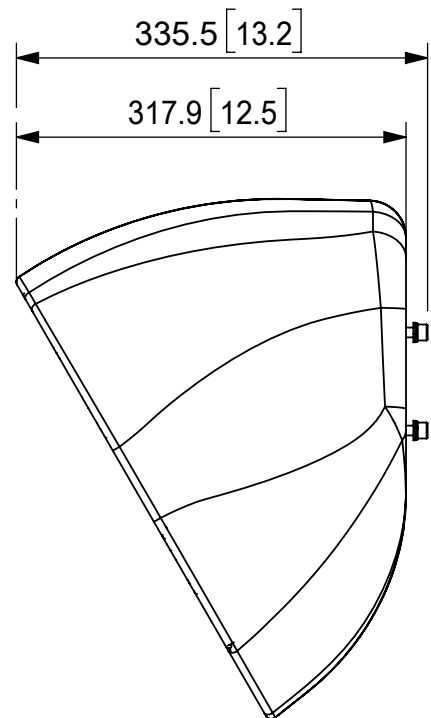
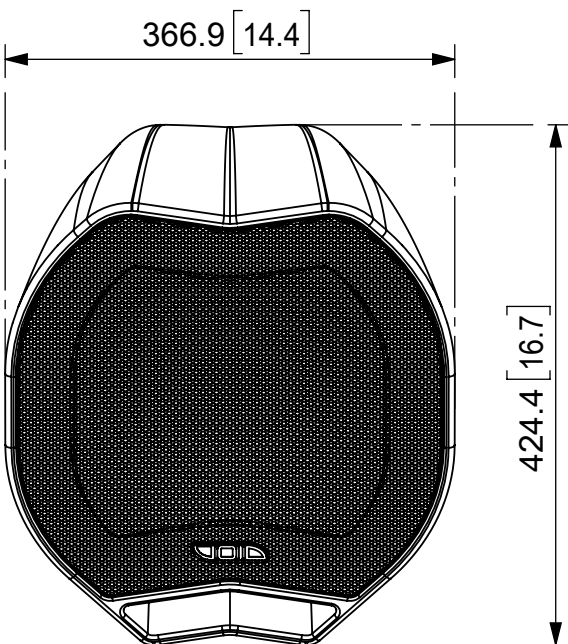
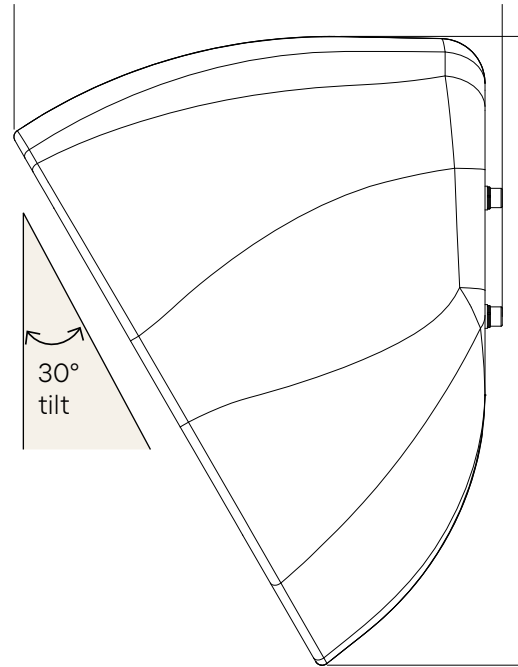
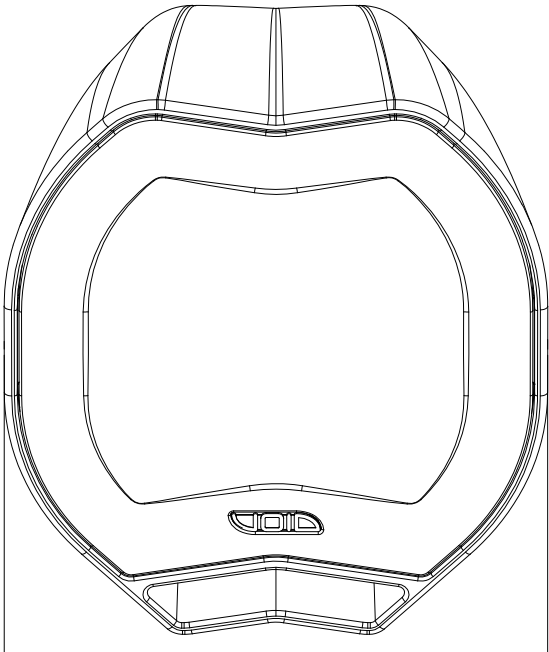

4.0 Cabling and Wiring

4.1 Electrical safety



To avoid electrical hazards please note the following:
 Do not access the inside of any electrical equipment.
 Refer servicing to Void-approved service agents.

4.2 Cable considerations for fixed installations

We recommend specifying installation-grade Low Smoke Zero Halogen (LSZH) cables for permanent installations. The cables should use Oxygen Free Copper (OFC) of grade C11000 or above. Cables for permanent installations should be compliant with the following standards:

- IEC 60332.1 Fire retardancy of a single cable
- IEC 60332.3C Fire retardancy of bunched cables
- IEC 60754.1 Amount of Halogen Gas Emissions
- IEC 60754.2 Degree of acidity of released gases
- IEC 61034.2 Measurement of smoke density.

We suggest using the following maximum copper cable lengths to keep level losses below 0.6 dB.

Metric mm ²	Imperial AWG	8 Ω load	4 Ω load	2 Ω load
2.50 mm ²	13 AWG	36m	18m	9m
4.00 mm ²	11 AWG	60m	30m	15m

4.3 Air 12 Wiring Diagram

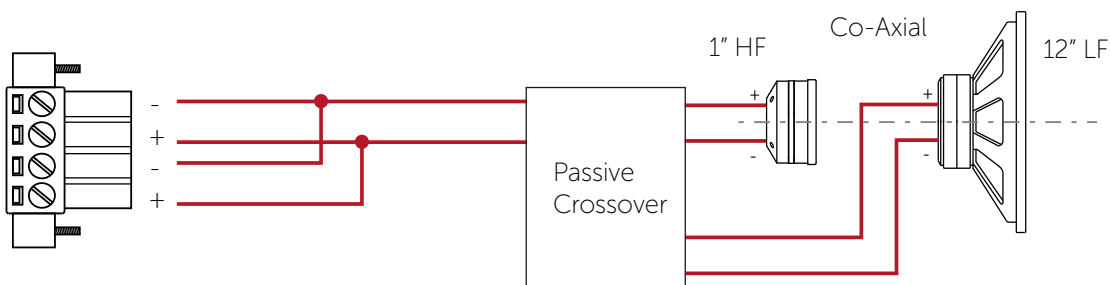
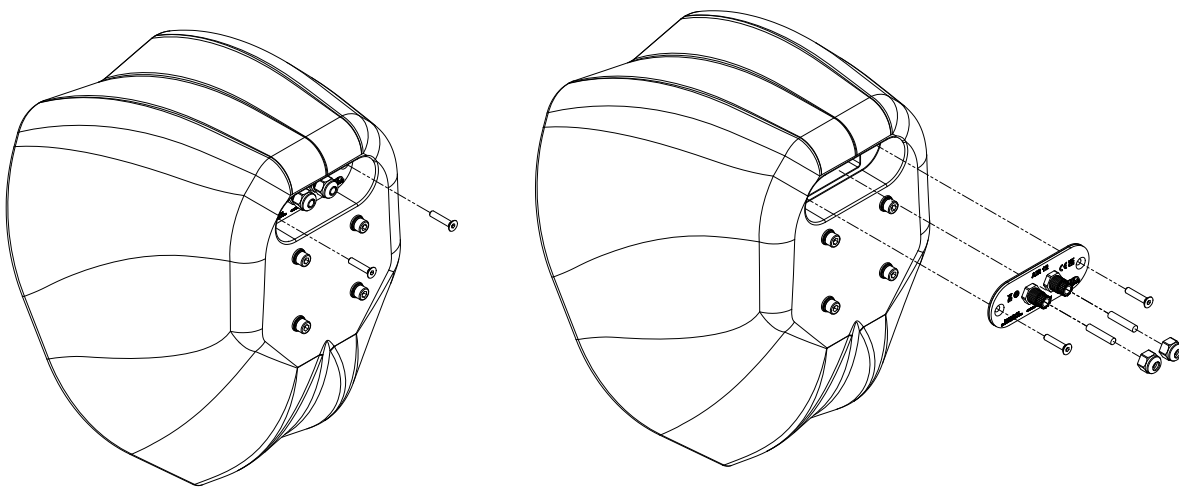

Figure 4.1: Air 12 wiring diagram

4.4 Air 12 gland connector wiring

- Remove the M6 bolts on the connector plate.
- Undo the collar of the glanded connectors on the connector plate and remove the rubber plugs. The collar does not need to be completely removed, just loosened.
- Insert the cable through the glanded connectors and terminate on the supplied Phoenix plug.
- Plug the Phoenix into the Air 12 loudspeaker and tighten the screws.
- Reposition the connector plate and attach using the M6 bolts. Tighten the collar of the gland around the cable.



4.5 Bias D1+/Q1+/Q1.5+/Q2+ Phoenix Wiring

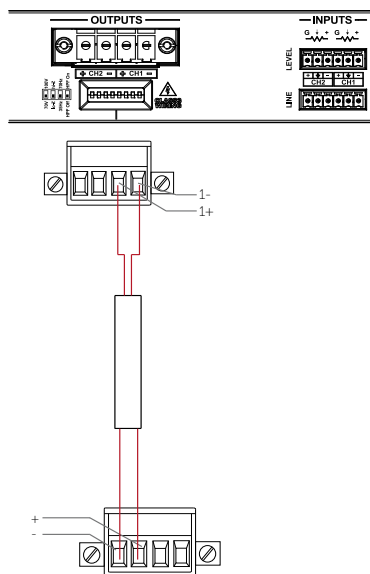

Figure 4.2: Bias D1+ wiring diagram

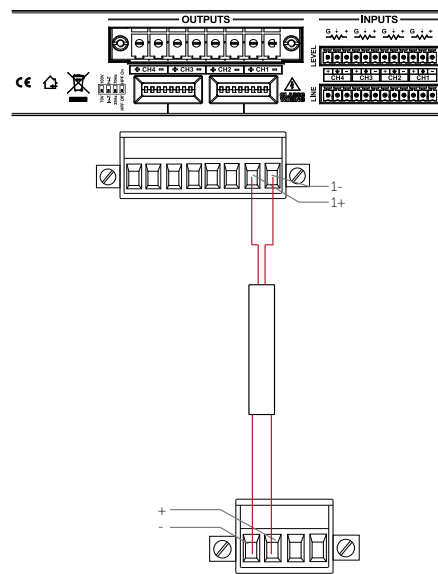

Figure 4.3: Bias Q1+/Q1.5+/Q2+ wiring diagram

4.6 Bias Q3/Q5 4-pin locking connector wiring

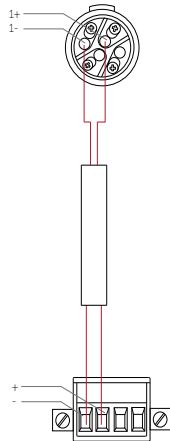
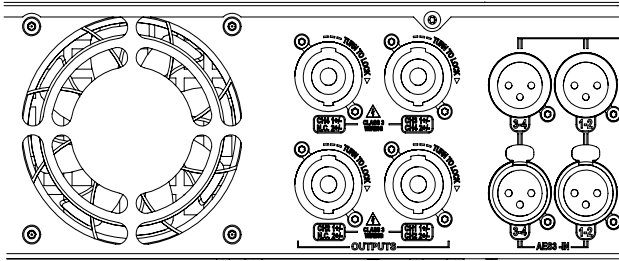

Figure 4.4: Bias Q3

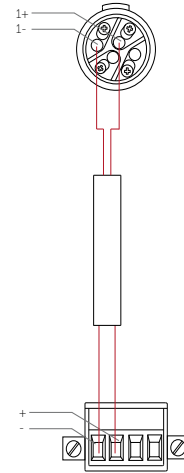
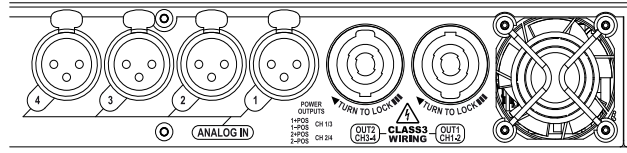

Figure 4.5: Bias Q5

4.7 Max Parallel Units

	Output
Output	400 W AES / 8 Ω
Max Parallel Units	4 (2 Ω load to amplifier)*

* Please make sure to select an amplifier with adequate power for your intended parallel configuration

* Half quoted max parallel units if bridging amp channels and consult your amplifier user guide for bridged wiring instructions

5.0 Mounting

5.1 Installation Safety

To avoid mechanical hazards, please note the following:



- Safety regulations vary in different regions. Full compliance with those regulations must be your priority.
 - Installations must only be undertaken by fully qualified and experienced engineers/technicians who understand local regulations.
 - This may include consulting a structural engineer before installation of wall brackets.
 - Remember that all personnel have a duty of care to themselves, to their assistants, to the venue staff and to the public.
- Before lifting any part of the system above head height, check for loose tools or other items that may fall and cause injury.
 - Do not use a telephone (even if hands-free) whilst installing. Always concentrate fully on the installation operation.
 - Do not install equipment that is worn, damaged, corroded, mishandled or overstressed in any way.
 - Use only Void-approved accessories that have been verified as safe to use with the loudspeaker.
 - Ensure that the ceiling or wall can safely support the combined weight of the loudspeaker and bracket. Mount only to solid, load-bearing structures. For hollow surfaces, fix into framework such as wall studs or ceiling joists, or reinforce the area before installation.
 - Use fixings suitable for both the structure and the load, and ensure that the bracket is securely fastened.
 - Use Nyloc nuts, or apply thread locker or equivalent methods to prevent fixings from loosening over time.



Secondary safeties should be provided in all instances where cabinets are flying or fixing overhead and should conform to local regulations.

Remove all four M8 bolts, washers and spring washers from the rear of the loudspeaker.

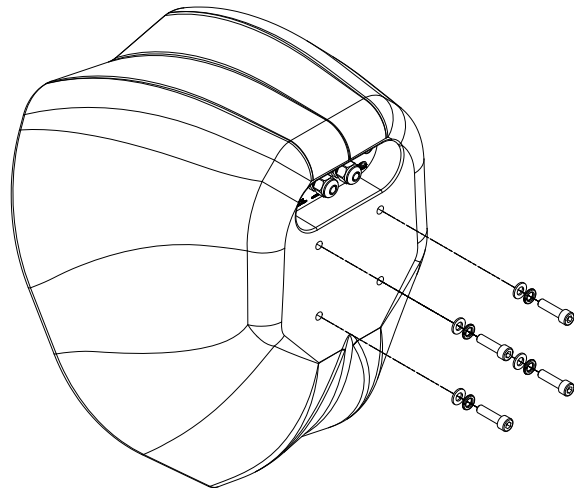

5.2 Air 12 Tilt Bracket Assembly

Air 12 has a downtilt of 30 degrees built into the enclosure design. Air 12 tilt bracket has a maximum vertical uptilt of +30 degrees, giving an effective tilt range of 0° to -30°.

IT6079 T80 - Swivel Bracket Assembly ● Black

IT6496 T80 - Swivel Bracket Assembly ○ White

Step 1

Separate the two components of the bracket by removing the two M8 bolts.

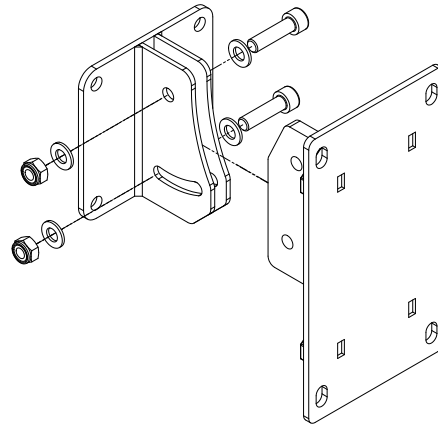

Step 2

Attach the front of the bracket to the speaker using four M8 Bolts, Washers and Spring Washers.

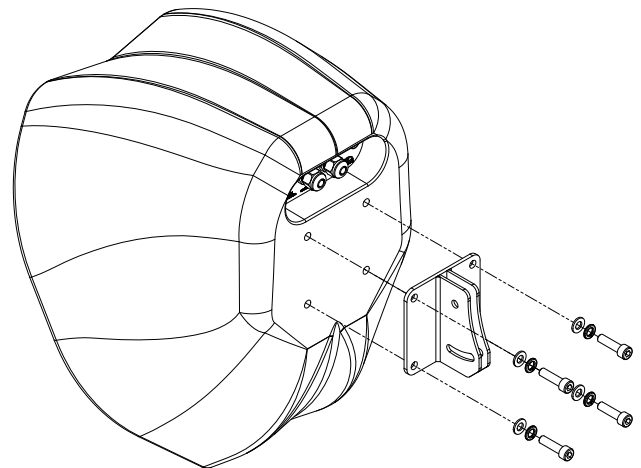

Step 3

Reattach the two components of the bracket together by lifting the Air 12 Loudspeaker, aligning it with its counterpart and securing using the two M8 Bolts, Washers and Nuts.

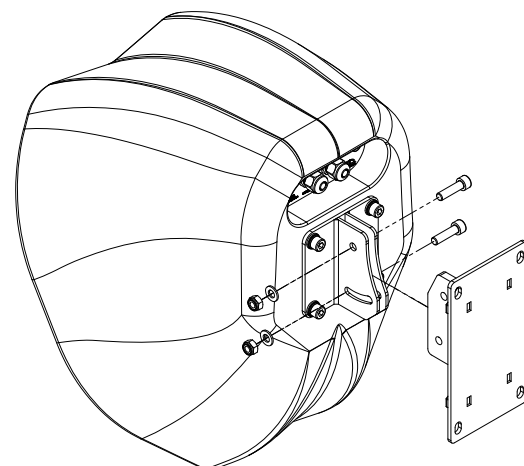

5.3 Air 12 Tilt Bracket Adjustability

Max Vertical Rotation: +30°, -0°

Max Horizontal Rotation: ±40°

Step 1

To adjust the horizontal angle, loosen the two M10 bolts on the top and bottom and manually adjust by pivoting bracket around the bolts. Refasten when the desired angle is reached.

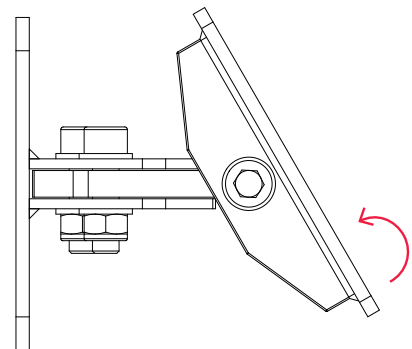
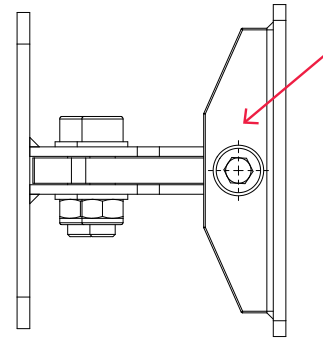

Step 2

To adjust the vertical angle, loosen the two M8 bolts and pivot the bracket around the top bolt. Refasten when the desired angle is reached.

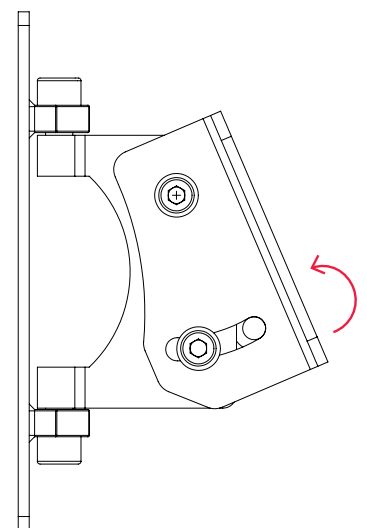
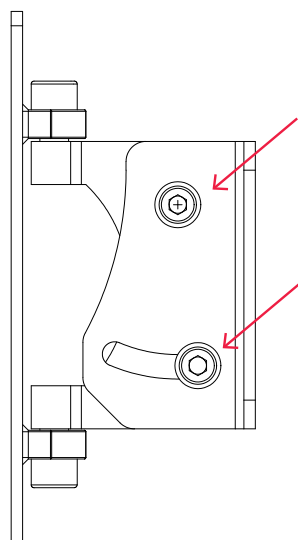

5.4 Air 12 Flush Mount Bracket assembly

IT6206 T80 - Flush Mount Bracket ● Black
 IT6499 T80 - Flush Mount Bracket ○ White

Step 1

Separate the two components by removing the M3 screws on either side and then simply lift them apart.

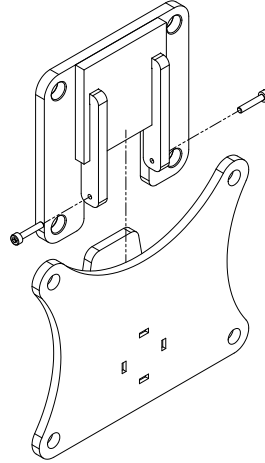

Step 2

Attach the top component of the bracket to the Air 12 using four M8 Bolts, Washers and Spring Washers.

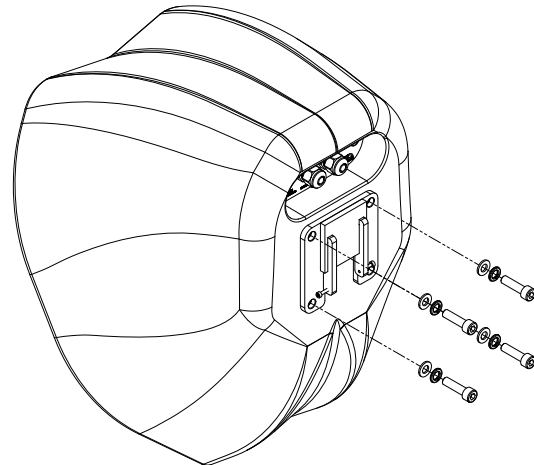

Step 3

Reattach the two components of the bracket together by lowering the Air 12 Loudspeaker, aligning it with its counterpart and securing using the two M3 Bolts.

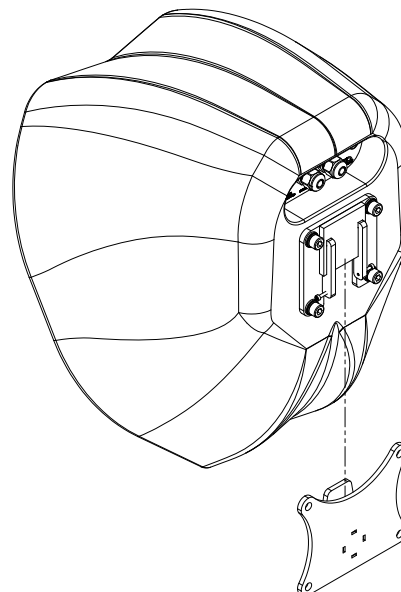

5.5 T80XL Wall Bracket Assembly

- IT1114 T80XL Wall Bracket ● Black
 IT1115 T80XL Wall Bracket ○ White

Step 1

Separate the two components by removing the M8 screw that secures them and lifting them apart.

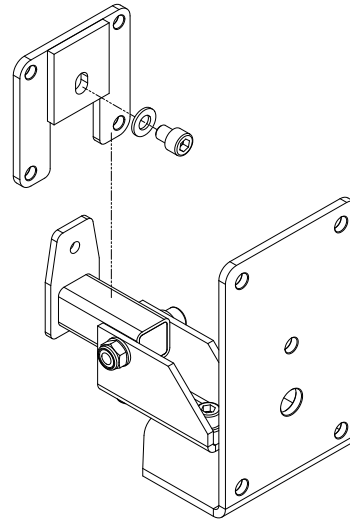

Step 2

Attach the top components of the bracket to the Air 12 using four M8 Bolts, Washers and Spring Washers.

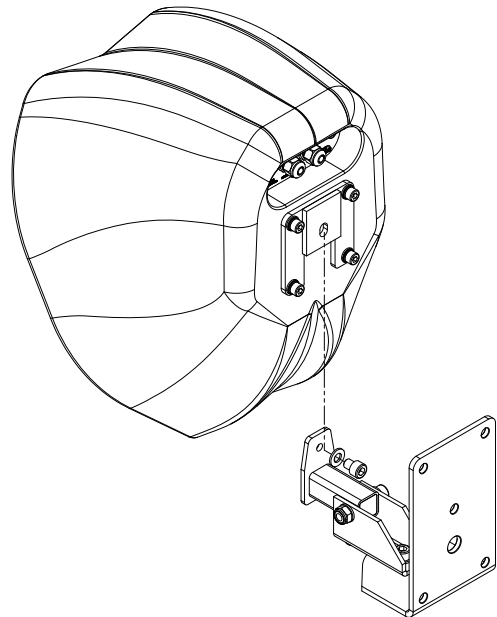

Step 3

Reattach the two components of the bracket together by lowering the Air 12 Loudspeaker, aligning it with its counterpart and securing using the M8 Bolts and Washer.

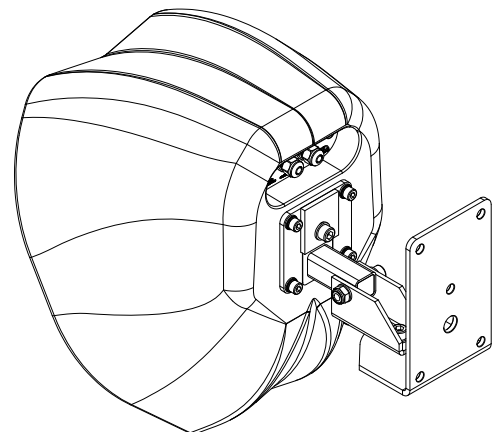

5.6 T80XL Wall Bracket Adjustability

Max Vertical Rotation: $+28^{\circ}$, -0°

Max Horizontal Rotation: $\pm 70^{\circ}$

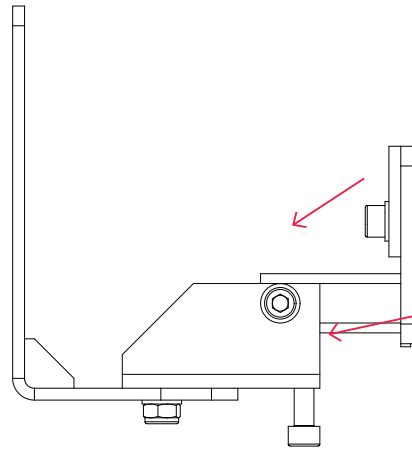

Step 1

To adjust the vertical angle, loosen the top M8 bolt and use the bottom vertical bolt to adjust the angle. Refasten when the desired angle is reached.

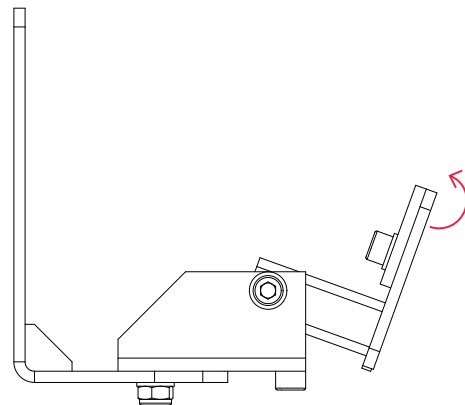

Step 2

To adjust the horizontal angle, loosen the M8 bolt and manually adjust by pivoting bracket around bolt. Refasten when the desired angle is reached.

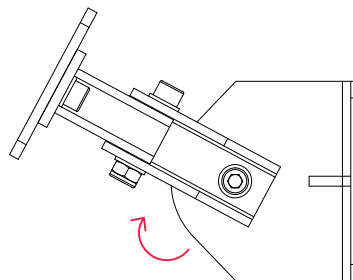
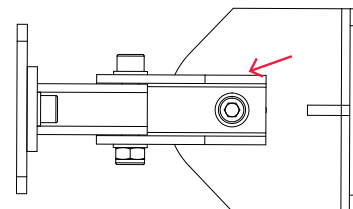

5.7 T80 Corner Bracket Assembly

- IT6492 Corner Bracket Assembly ● Black
- IT6500 Corner Bracket Assembly ○ White

Step 1

Separate the two components by removing the M8 screw that secures them and lifting them apart.

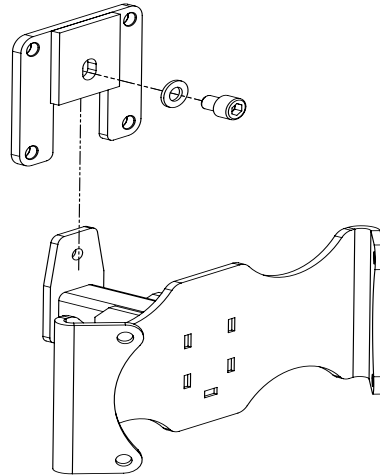

Step 2

Attach the top components of the bracket to the Air 12 using four M8 Bolts, Washers and Spring Washers.

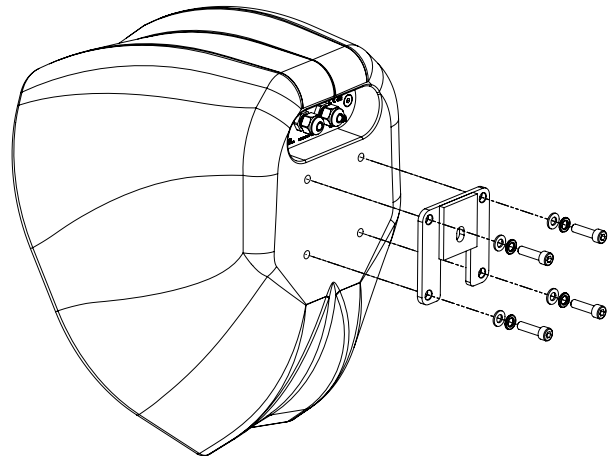

Step 3

Reattach the two components of the bracket together by lowering the Air 12 Loudspeaker, aligning it with its counterpart and securing using the M8 Bolts and Washer.

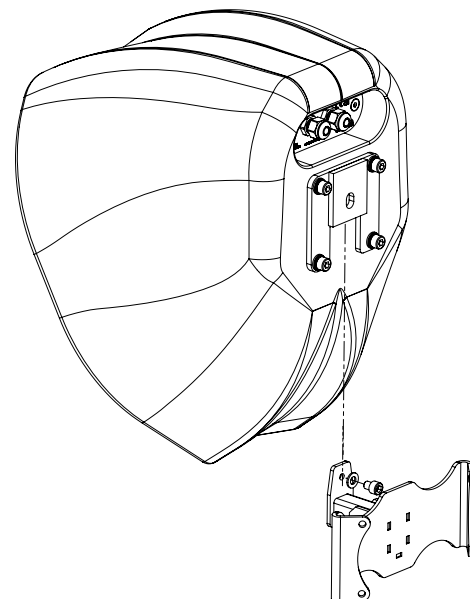

5.8 T80 Corner Bracket Adjustability

Max Vertical Rotation: +30°, -33°

Max Horizontal Rotation: 0°

Step 1

To adjust the vertical angle, loosen the top M8 bolt and use the bottom vertical bolt to adjust the angle. Refasten when the desired angle is reached.

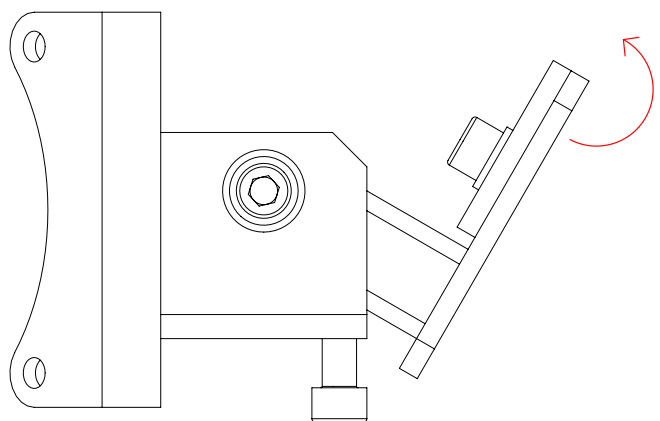
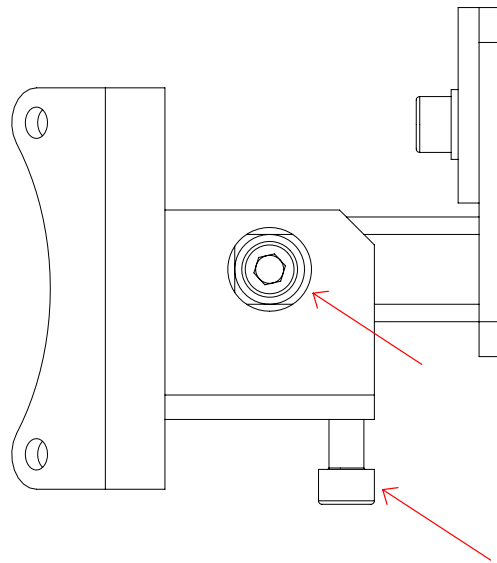

5.9 T80 Ceiling Bracket Assembly

IT1105	T80 Ceiling Bracket	● Black
IT1106	T80 Ceiling Bracket	○ White

Step 1

Separate the two components by removing the M10 Nut and Washer that secures the two components together.

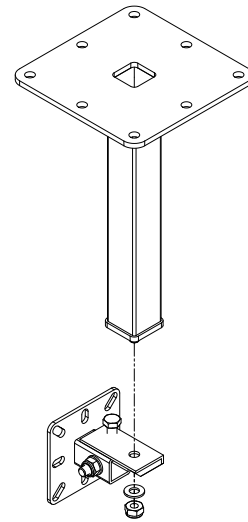

Step 2

Attach the bottom components of the bracket to the Air 12 using four M8 Bolts, Washers and Spring Washers.

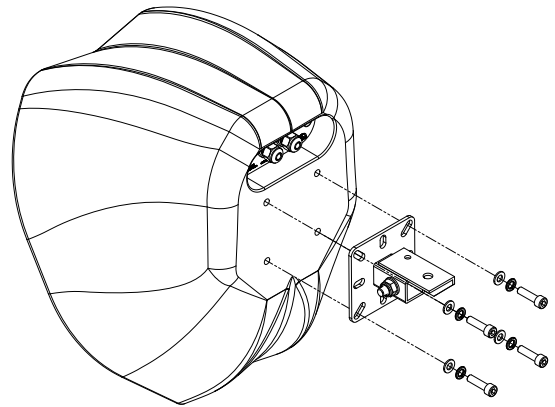

Step 3

Reattach the two components of the bracket together by lifting the Air 12 Loudspeaker, aligning it with the M8 Bolt and then securing using the nut and washer.

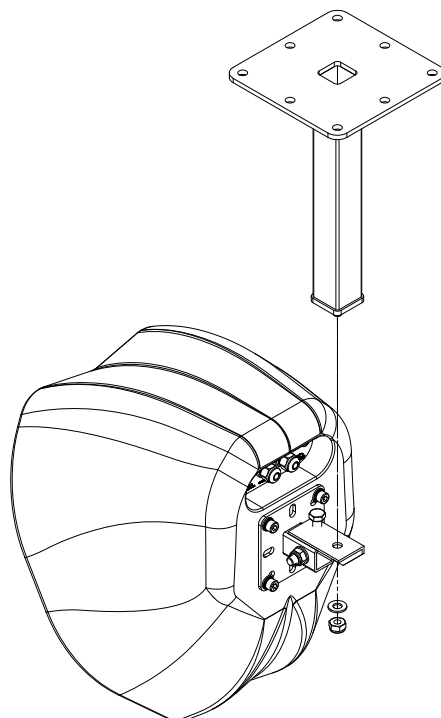

5.10 T80 Ceiling Bracket Adjustability

Max Vertical Rotation: $\pm 12^\circ$

Max Horizontal Rotation: 360°

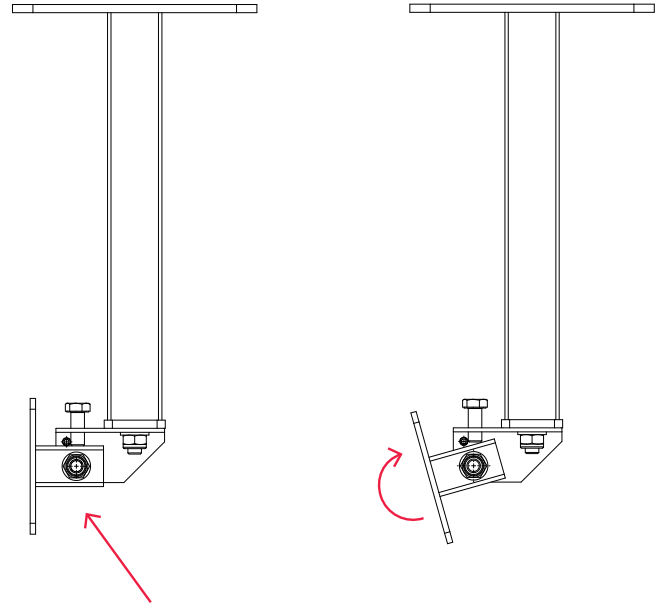

Step 1

To adjust the vertical angle, loosen the M8 bolt and use the top vertical bolt to adjust the angle. Refasten when the desired angle is reached.

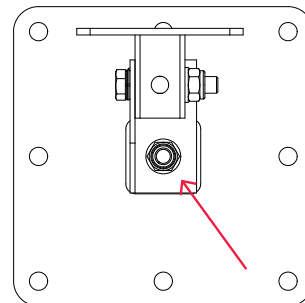

Step 2

To adjust the horizontal angle, loosen the M8 bolt and manually adjust by pivoting bracket around bolt. Refasten when the desired angle is reached.

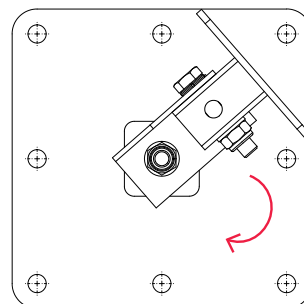

5.11 T80 Pole Bracket Assembly

- IT3725 T80 Pole Bracket ● Black
- IT3726 T80 Pole Bracket ○ White

Step 1

To attach the two components, fasten the M12 bolt and washers through the top hat casing.

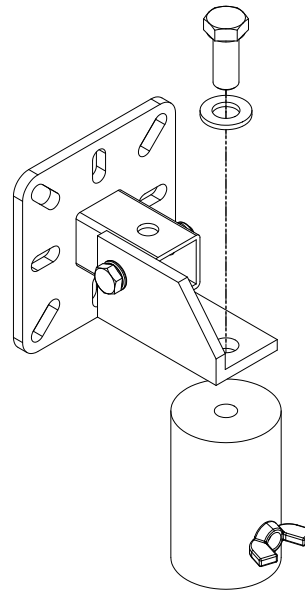

Step 2

Attach the bracket to the Air 12 using four M8 Bolts, Washers and Spring Washers.

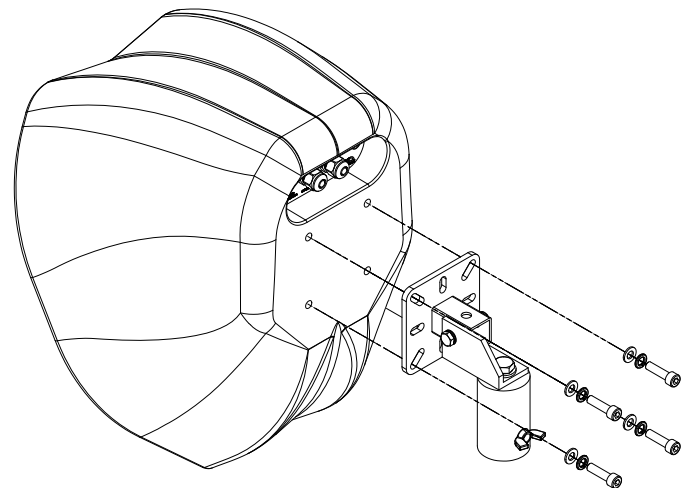

Step 3

Lift the speaker and align and place on pre-installed pole. Use the wing bolt to secure it in place.

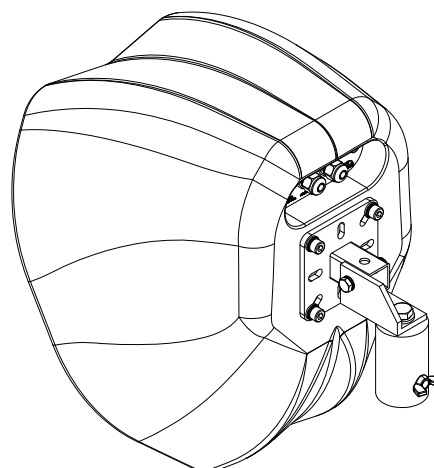

5.12 T80 Pole Bracket Adjustability

Max Vertical Rotation: $+28^{\circ}$, -0°

Max Horizontal Rotation: 360°

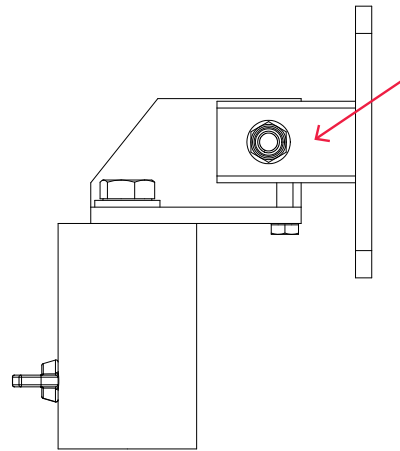

Step 1

To adjust the vertical angle, loosen the top M8 bolt and use the bottom vertical bolt to adjust the angle. Refasten when the desired angle is reached.

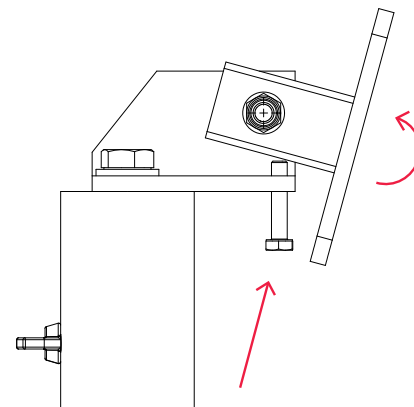

Step 2

To adjust the horizontal angle, loosen the M8 bolt and manually adjust by pivoting bracket around bolt. Refasten when the desired angle is reached.

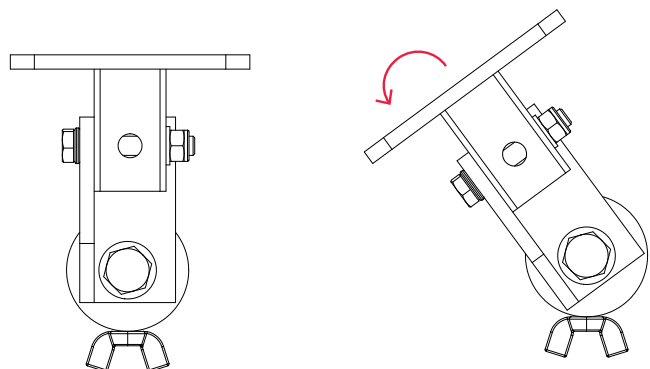

6.0 Maintenance

6.1 Cleaning and Maintenance

The following guide will help to prevent corrosion and prolong both the product aesthetics and sonic performance. It is recommended that this process is implemented weekly.

Step 1

Wash the grille with deionised water, ensuring all build-up of contamination is removed completely from the grille and the foam.

Step 2

Using a clean microfibre cloth and deionised water, use circular motions working from the top of the product down to remove contamination. Dry the product with a clean, dry microfibre cloth.

Step 3

Use a soft bristled brush and deionised water to clean the bracketry, ensuring all contamination is removed completely.

7.0 Service

7.1 Return authorisation

Before returning your faulty product for repair, please remember to get an R.A.N. (Return Authorisation Number) from the Void dealer who supplied the system to you. Your dealer will handle the necessary paperwork and repair. Failure to go through this return authorisation procedure could delay the repair of your product.

Note that your dealer will need to see a copy of your sales receipt as proof of purchase so please have this to hand when applying for return authorisation.

7.2 Shipping and packing considerations

- When sending a Void Air 12 loudspeaker to an authorised service centre, please write a detailed description of the fault and list any other equipment used in conjunction with the faulty product.
- Accessories will not be required. Do not send the cables or any other hardware unless your dealer asks you to.
- Pack your unit in the original factory packaging if possible. Include a note of the fault description with the product. Do not send it separately.
- Ensure safe transportation of your unit to the authorised service centre.
- Put a copy of the R.A.N. inside the packaging and on the outside of the box.

8.0 Appendix

8.1 Architectural specification

The loudspeaker shall be a passive, two-way system consisting of one high power 12" (304.8 mm) low frequency (LF) transducer and a 1" (25.4 mm) coaxial high frequency (HF) compression driver mounted in a direct radiating, reflex loaded, aesthetically designed enclosure.

The enclosure shall be constructed of low resonance fibreglass composite with a smooth cellulose finish and shall include integral threaded inserts for the fitment of mounting hardware. The external dimensions are (H) 425 mm x (W) 367 mm x (D) 330 mm (16.7" x 14.5" x 13"). Weight is 12.5kg (27.6lbs).

Performance specifications of a typical production unit shall be as follows: frequency response of 75 Hz - 20 kHz (-10 dB IEC 60268-5); Power handling shall be 400 W AES at a rated impedance of 8 Ω .

The wiring connection shall be via a single removable lockable wiring connector with four screw-down terminals (one pair for input and one pair for loop-out to another loudspeaker) to provide secure wiring and to allow for pre-wiring of the connector before the installation. This connector should then screw lock to the enclosure to ensure secure attachment.

The low frequency transducer shall feature a neodymium magnet structure and be constructed on a resonant free and heavy-duty basket design with a 3" (75.5 mm) voice coil, wound with copper wire on a high-quality former for high power handling and long-term reliability.

The loudspeaker system shall be a Void Acoustics Air 12.

8.2 Changelog

Document Version	Notes	Valid for S.N
TD11013-1.0	Initial Release	A12XXXX - Current
TD11013-1.1	Updated specs to IEC 60268-5	A12XXXX - Current

HEAD OFFICE

Void Acoustics Research Ltd,
Unit L The Fulcrum, Vantage Way,
Poole, Dorset,
BH12 4NU
United Kingdom

Call: +44(0) 1202 666006

Email: hello@voidacoustics.com

NORTH AMERICA

Void Acoustics North America

Call: +1(630) 6866616

Email: hello@voidacoustics.com

voidacoustics.com

