

VOID

Hear. Feel. Connect.

voidacoustics.com

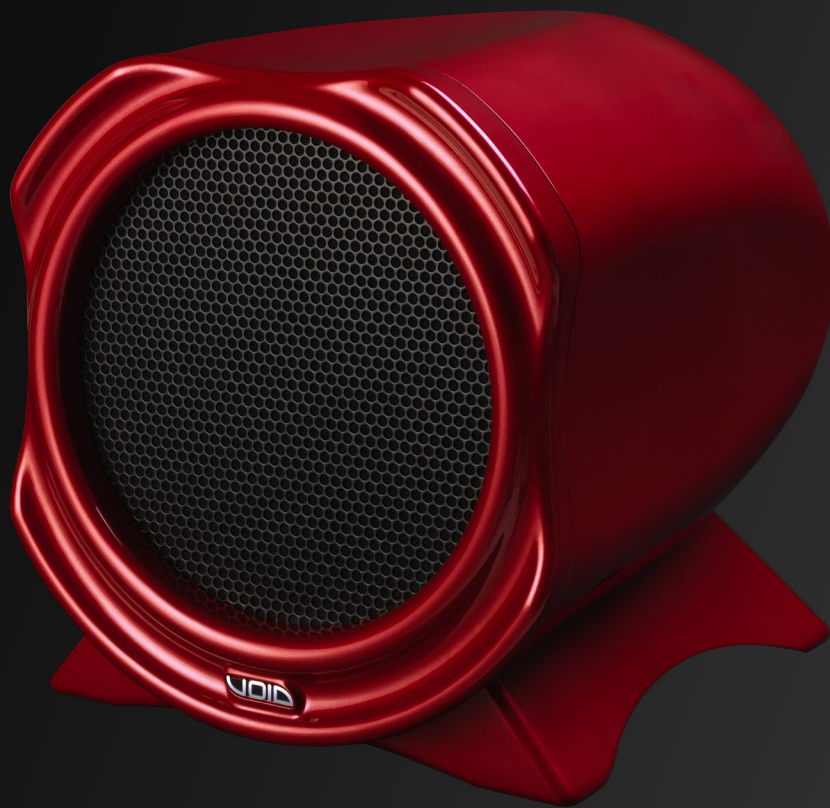

Air 15

Prominent Power & Effective Styling

USER GUIDE V1.1

©2026 Void Acoustics Research Ltd.

This user guide is subject to change without notice.
For the latest online version, visit: www.voidacoustics.com

Void Acoustics and the Void logo are registered trademarks of Void Acoustics Research Ltd. in the United Kingdom, USA and other countries; all other Void trademarks are the property of Void Acoustics Research Ltd.

Contents

1	Safety and Regulations	4
1.1	Important Safety Instructions	4
1.2	Limitations	4
1.3	EC Declaration of Conformity	4
1.4	UKCA Conformity	4
1.5	Warranty Statement	4
1.6	WEEE Directive	4
2	Unpacking and Checking	5
3	About	6
3.1	Welcome	6
3.2	Air 15 Overview	6
3.3	Key Features	6
3.4	Air 15 Specifications	7
3.5	Air 15 Dimensions	8
4	Cable and Wiring	9
4.1	Electrical Safety	9
4.2	Cable Considerations for Fixed Installations	9
4.3	Phoenix Connector	9
4.4	Glanded Connector Wiring	10
4.5	Air 15 Wiring Diagram	11
4.6	Bias D1/Q2 Phoenix Wiring	12
4.7	Bias Q3/Q5 4-pin locking connector Wiring	12
5	Service	13
5.1	Return Authorisation	13
5.2	Shipping and Packaging Considerations	13
6	Appendix	14
6.1	Architectural Specifications	14
6.2	Changelog	14

1 Safety and Regulations

1.1 Important safety instructions



The lightning flash with an arrowhead symbol within an equilateral triangle is intended to alert the user to the presence of uninsulated "dangerous voltage" within the product's enclosure that may be of sufficient magnitude to constitute a risk of electric shock to persons.



The exclamation point within an equilateral triangle is intended to alert the user of the presence of important operating and maintenance (servicing) instructions in the literature accompanying the appliance.

Safety instructions - read this first

1. Read these instructions.
2. Keep these instructions.
3. Heed all warnings.
4. Follow all instructions.
5. Do not use this apparatus near water.
6. Clean only with a dry cloth.
7. Do not block any ventilation openings. Install in accordance with the manufacturer's instructions.
8. Do not install near any heat source such as radiators, heat registers, stoves, or other such apparatus that produce heat.
9. Do not defeat the safety purpose of the grounding-type plug. A grounding type plug has two blades and a third grounding prong. The third prong is provided for your safety. If the provided plug does not fit into your outlet, consult an electrician for replacement of the obsolete outlet.
10. Protect power cords from being walked on or pinched particularly at plugs, convenience receptacles, and the point where they exit the apparatus.
11. Only use attachments and accessories specified by Void Acoustics.
12. Only use with the cart, stand, tripod, bracket, or table specified by the manufacturer, or sold with the apparatus. When a cart is used, use caution when moving the cart/apparatus combination to avoid injury from tip-over.
13. Unplug the apparatus during lightning storms or when unused for long periods of time.
14. Refer all servicing to qualified service personnel. Servicing is required when the apparatus has been damaged in any way, such as when the power-supply cord or plug is damaged, liquid has been spilled or objects have fallen into the apparatus, the apparatus has been exposed to rain or moisture, does not operate normally, or has been dropped.
15. Since the mains power supply cord attachment plug is used to disconnect the device, the plug should always be easily accessible.
16. Void loudspeakers can produce sound levels capable of causing permanent hearing damage from prolonged exposure. The higher the sound level, the less exposure needed to cause such damage. Avoid prolonged exposure to the high sound levels from the loudspeaker.

1.2 Limitations

This guide is provided to help familiarise the user with the loudspeaker system and its accessories. It is not intended to provide comprehensive electrical, fire, mechanical and noise training and is not a substitute for industry-approved training. Nor does this guide absolve the user of their obligation to comply with all relevant safety legislation and codes of practice. While every care has been taken in creating this guide, safety is user-dependent and Void Acoustics Research Ltd cannot guarantee complete safety whenever the system is rigged and operated.

1.3 EC declaration of conformity

For EC Declaration of Conformity please go to:

www.voidacoustics.com/eu-declaration-loudspeakers

1.4 UKCA marking

For details of the UKCA marking go to:

www.voidacoustics.com/uk-declaration-loudspeakers

1.5 Warranty statement

For warranty statement go to:

<https://voidacoustics.com/terms-conditions/>

1.6 WEEE directive

If the time arises to throw away your product, please recycle all the components possible.



This symbol indicates that when the end-user wishes to discard this product, it must be sent to separate collection facilities for recovery and recycling. By separating this product from other household-type waste, the volume of waste sent to incinerators or land-fills will be reduced and natural resources will thus be conserved.

The Waste Electrical and Electronic Equipment Directive (WEEE Directive) aims to minimise the impact of electrical and electronic goods on the environment. Void Acoustics Research Ltd complies with the Directive 2002/96/EC and 2003/108/EC of the European Parliament on waste electrical and electronic equipment (WEEE) in order to reduce the amount of WEEE that is being disposed of in land-fill sites. All of our products are marked with the WEEE symbol; this indicates that this product must NOT be disposed of with other waste. Instead it is the user's responsibility to dispose of their waste electrical and electronic equipment by handing it over to an approved reprocessor, or by returning it to Void Acoustics Research Ltd for reprocessing. For more information about where you can send your waste equipment for recycling, please contact Void Acoustics Research Ltd or one of your local distributors.



2 Unpacking and Checking

All Void Acoustics products are carefully manufactured and thoroughly tested before being despatched. Your dealer will ensure that your Void products are in pristine condition before being forwarded to you but mistakes and accidents can happen.

Before signing for your delivery:

- Inspect your shipment for any signs of contamination, abuse or transit damage as soon as you receive it
- Check your Void Acoustics delivery fully against your order
- If your shipment is incomplete or any of its contents are found to be damaged; inform the shipping company and inform your dealer.

3 About

3.1 Welcome

Many thanks for purchasing this Void Acoustics Air Series loudspeaker. We truly appreciate your support. At Void, we design, manufacture and distribute advanced professional audio systems for the installed and live sound market sectors. Like all Void products, our highly skilled and experienced engineers have successfully combined pioneering technologies with ground-breaking design aesthetics, to bring you superior sound quality and visual innovation. In buying this product, you are now part of the Void family and we hope using it brings you years of satisfaction. This guide will help you both use this product safely and ensure it performs to its full capability.

3.2 Air 15 overview

The Air 15 is a reflex-loaded 15" fibreglass subwoofer with styling that compliments mid-high enclosures from both the Air and Cyclone series. Its large-scale output allows fully formed systems to be achieved in any environment.

Air 15's non-resonant fibreglass enclosure contributes to its impressive SPL and low frequency extension capabilities. Key features include an IP-X3 rating made possible by 'ingress proof vent technology' and UV-resilient paint, allowing Air 15 to perform in both internal and external spaces requiring comprehensive coverage. Perfect for medium sized nightclubs and dance venues, larger bars, restaurants and beach clubs, retail settings and theme parks.

3.3 Key features

- Reflex-loaded 15 inch subwoofer
- Tough, high-excursion transducer with 4 inch voice coil
- Low-resonance fibreglass composite construction
- Weather-resistant input glands with Phoenix connector and link-through functionality
- Stainless steel fittings
- Visually striking appearance for style led environment
- Available as standard in red with a black grille, black and a black grille, and white with a white grille. Custom RAL and KROME finishes are available upon request.

3 About

3.4 Air 15 specifications

Frequency Response ¹	40 Hz - Preset dependent
Maximum Output ²	123 dB cont, 129 dB peak
Nominal Dispersion	Array dependent
Sensitivity ³	98 dB 1W/1m
Driver Configuration	1 x 15" LF
Power Handling	800 W AES
Nominal Impedance	8 Ω
Suggested Minimum Amplifier	Bias Q1.5+
Weight	37.7 kg (83.1 lbs)
IP Rating	IP-X3
Connections	Phoenix connector with link out
Enclosure	Fibreglass composite
Finish	Smooth cellulose
Height	551 mm (21.7")
Width	487 mm (19.2")
Depth	644 mm (25.4")

1 -10 dB IEC 60268-5 2 Calculated 3 Measured in half space

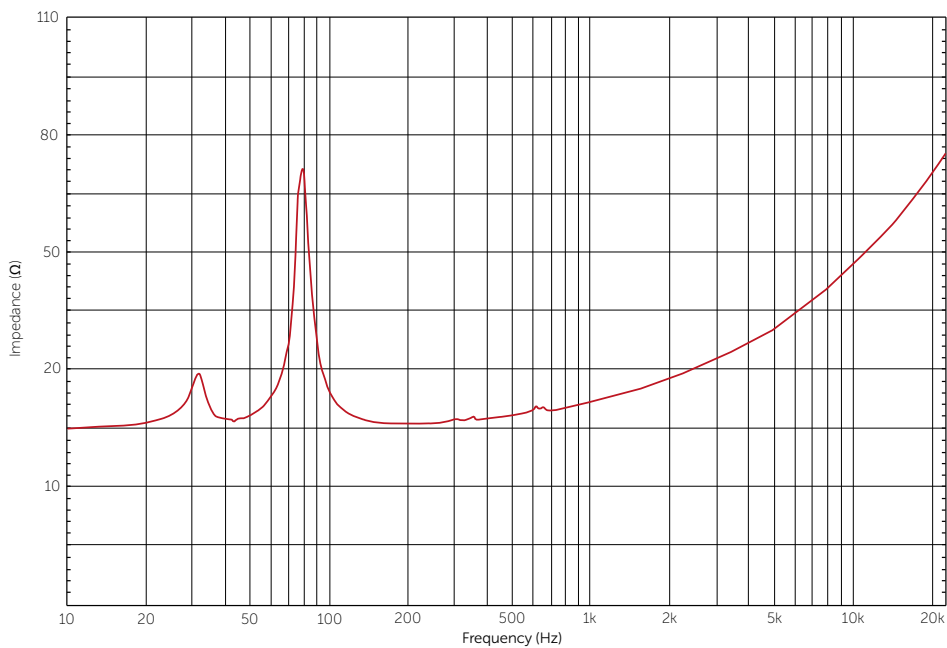

Figure 3.1: Impedance graph

3 About

3.5 Air 15 dimensions

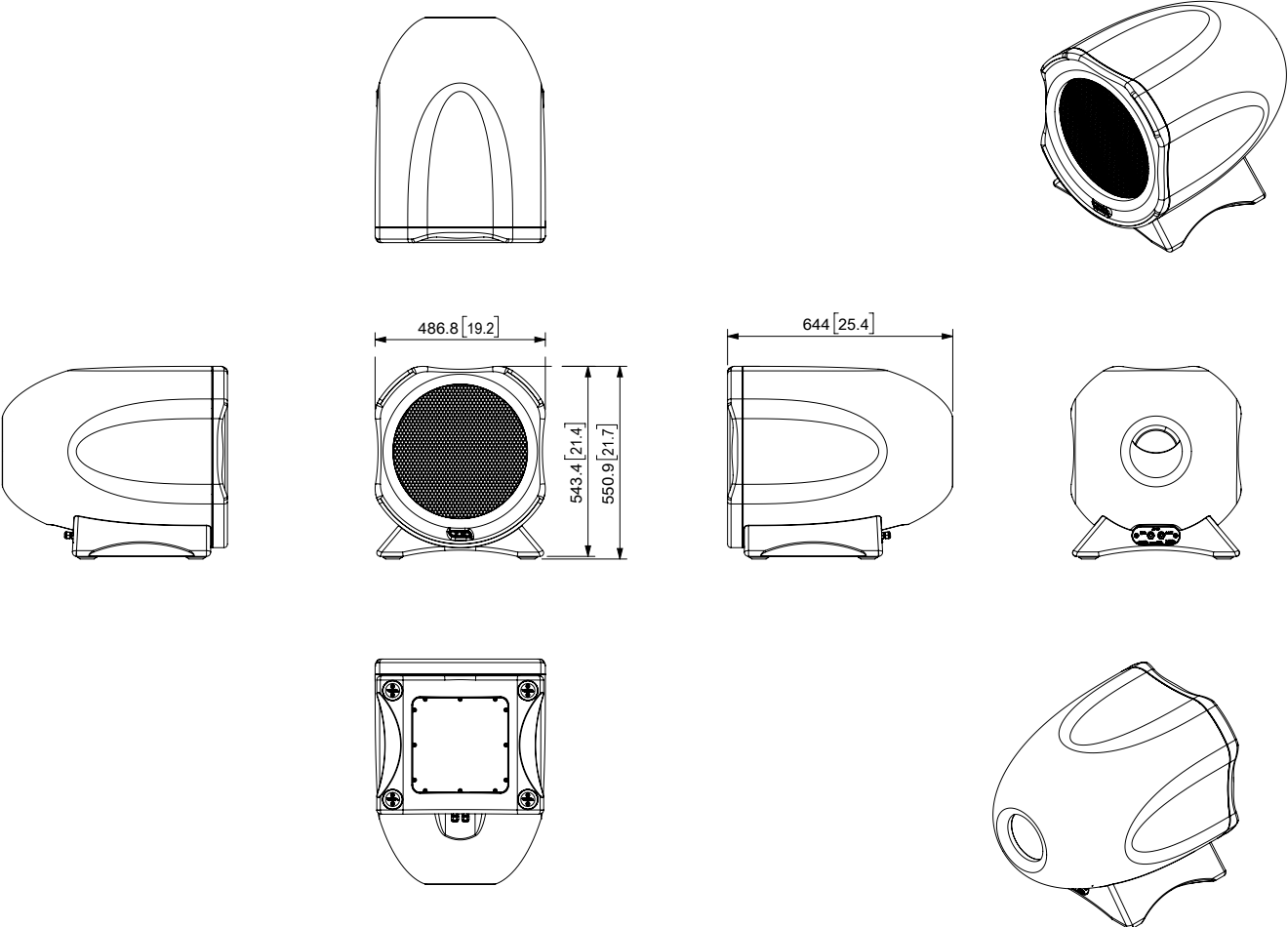

Figure 3.2: Dimensions

4 Cable and Wiring

4.1 Electrical safety



To avoid electrical hazards please note the following:

- Do not access the inside of any electrical equipment. Refer servicing to Void-approved service agents.

4.2 Cable considerations for fixed installations

We recommend specifying installation-grade Low Smoke Zero Halogen (LSZH) cables for permanent installations. The cables should use Oxygen Free Copper (OFC) of grade C11000 or above. Cables for permanent installations should be compliant with the following standards:

- IEC 60332.1 Fire retardancy of a single cable
- IEC 60332.3C Fire retardancy of bunched cables
- IEC 60754.1 Amount of Halogen Gas Emissions
- IEC 60754.2 Degree of acidity of released gases
- IEC 61034.2 Measurement of smoke density.

We suggest using the following maximum copper cable lengths to keep level losses below 0.6 dB.

Metric mm ²	Imperial AWG	8 Ω load	4 Ω load	2 Ω load
2.50 mm ²	13 AWG	36 m	18 m	9 m
4.00 mm ²	11 AWG	60 m	30 m	15 m

4.3 Phoenix connector

Figure 4.1 shows the rear panel of a Air 15 loudspeaker with the polarity of the Phoenix connector labelled. When viewed from the rear the connectors are negative, positive, negative, positive, from left to right.

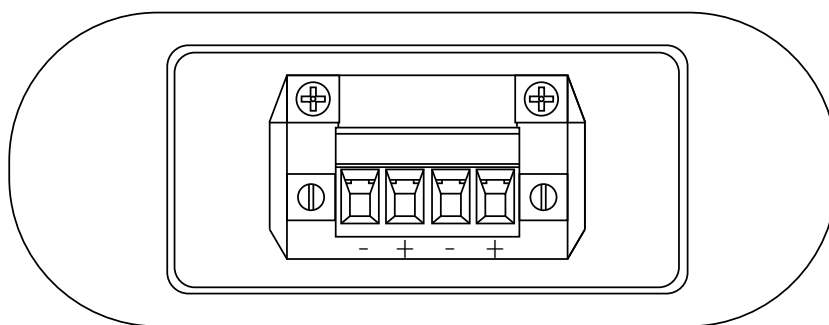

Figure 4.1: Phoenix connector diagram

4 Cable and Wiring

4.4 Glanded connector wiring

Remove all both M6 bolts from the rear of the connector plate.

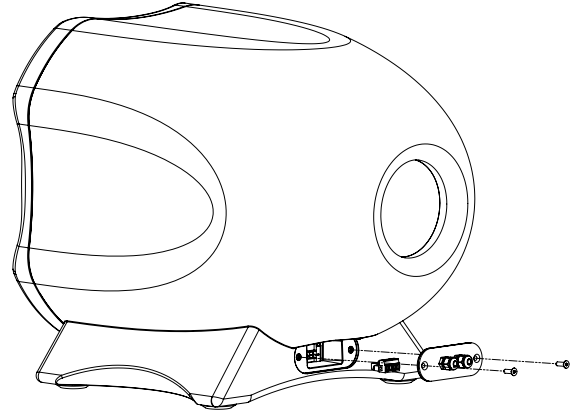

Figure 4.2: Connector plate removal

Undo the glanded connectors from the rear of the connector plate and remove the rubber plugs from the connectors.

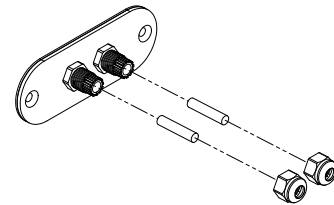

Figure 4.3: Glanded connector removal

Insert the cable through the glanded connectors and insert the cable into the connector block as shown.

(Note: The configuration with two cables is for use with link out, if attaching only one Air 15 then re-insert one of the rubber plugs into the unused glanded connector.)

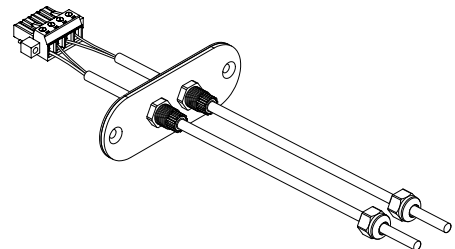

Figure 4.4: Cable connection

4 Cable and Wiring

Attach the cable to the phoenix connector then position the connector plate and attach it using the M6 bolts.

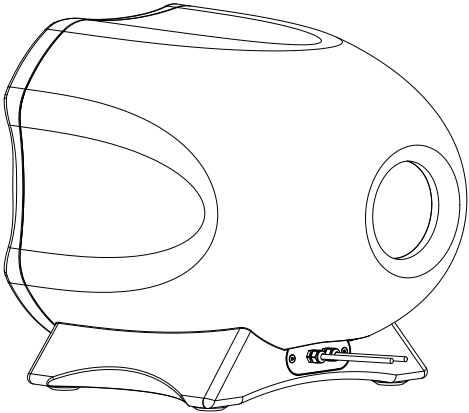

Figure 4.5: Phoenix attachment

4.5 Air 15 wiring diagram

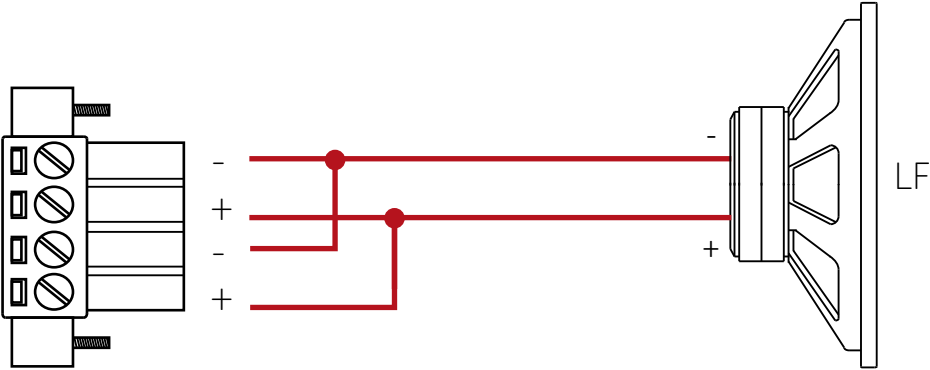

Figure 4.6: Air 15 wiring diagram

4 Cable and Wiring

4.6 Bias D1/Q2 Phoenix wiring

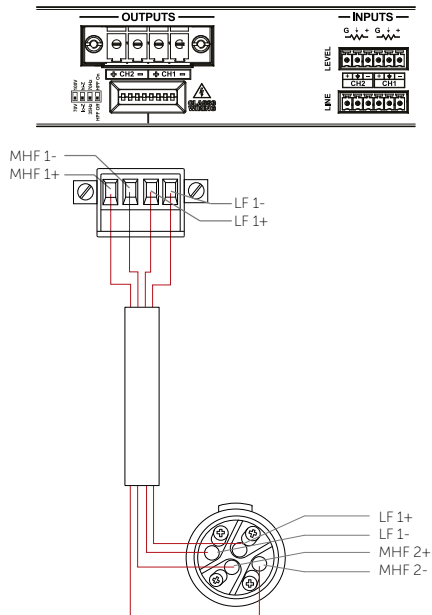

Figure 4.7: Bias D1 output connection

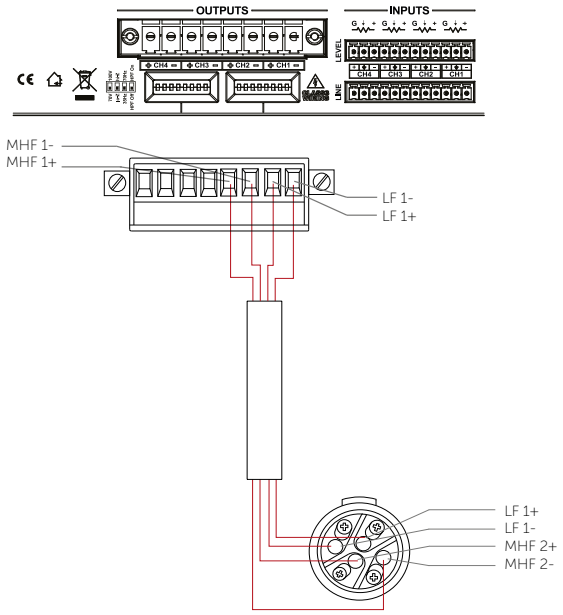

Figure 4.8: Bias Q2 output connection

Bias D1/Q2	Out 1
Output	LF (12")
Max parallel units	4 (2 Ω load to amplifier)

4.7 Bias Q3/Q5 4-pin locking connector wiring

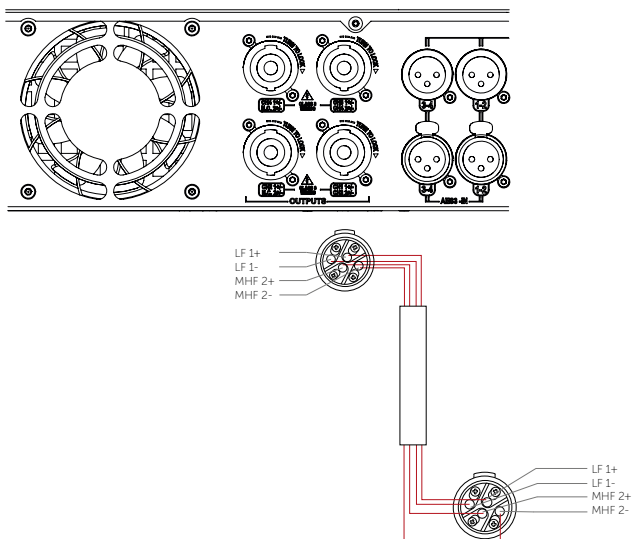

Figure 4.9: Bias Q3

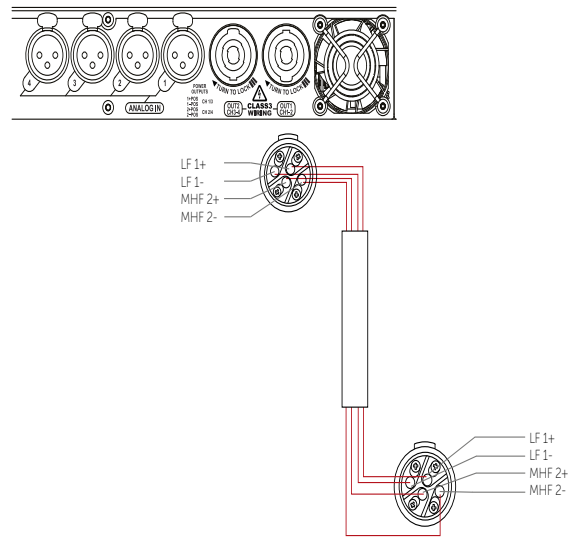

Figure 4.10: Bias Q5

Bias Q3/Q5	Out 1
Output	LF (12")
Max quantity per channel	4 (2 Ω load to amplifier)

5 Service

Void Air Series loudspeakers should only be serviced by a fully-trained technician.



No user serviceable parts inside. Refer servicing to your dealer.

5.1 Return authorisation

Before returning your faulty product for repair, please remember to get an R.A.N. (Return Authorisation Number) from the Void dealer who supplied the system to you. Your dealer will handle the necessary paperwork and repair. Failure to go through this return authorisation procedure could delay the repair of your product.

Note that your dealer will need to see a copy of your sales receipt as proof of purchase so please have this to hand when applying for return authorisation.

5.2 Shipping and packing considerations

- When sending a Air Series loudspeaker to an authorised service centre, please write a detailed description of the fault and list any other equipment used in conjunction with the faulty product.
- Accessories will not be required. Do not send the instruction manual, cables or any other hardware unless your dealer asks you to.
- Pack your unit in the original factory packaging if possible. Include a note of the fault description with the product. Do not send it separately.
- Ensure safe transportation of your unit to the authorised service centre.

6 Appendix

6.1 Architectural specification

The loudspeaker shall be a reflex-loaded 15" low frequency loudspeaker comprised of a single high-power handling 15" (381 mm) low frequency (LF) transducer in a reflex loaded non-resonant fibreglass enclosure.

The low frequency transducer shall be constructed on a resonant free and heavy-duty aluminium basket with a water-resistant treated paper cone, featuring a 4" (101 mm) voice coil, wound with copper wire on a high-quality voice coil former, for high power handling and long-term reliability.

Performance specifications for a typical production unit shall be as follows: the usable on-axis bandwidth shall be 40 Hz – preset dependent Hz (-10 dB IEC 60268-5) with a maximum SPL of 129 dB peak measured at 1 m using IEC268-5 pink noise. Power handling shall be 800 W AES at a rated impedance of 8 Ω .

The wiring connection shall be as follows: a removable, lockable wiring connector with four screw-down terminals (one pair for input and one pair for link through to another loudspeaker) to provide secure wiring and allow for pre-wiring of the connector before the installation (this connector should then screw lock to the enclosure for secure attachment).

The enclosure shall be of a moulded fibreglass reinforced plastic construction with a smooth cellulose finish and UV-resilient paint. External dimensions shall be (H) 551 mm x (W) 487 x (D) 644. The weight shall be 37.7 kg (83.11 lbs).

The loudspeaker shall be a Void Acoustics Air 15.

6.2 Changelog

Document Version	Notes	Valid for S.N
UG10709-1.2	Updated specs to IEC 60268-5	A15XXXX - Current

NORTH AMERICA

Void Acoustics North America

Call: +1 (630) 686 6616

Email: sales.usa@voidacoustics.com

HEAD OFFICE

Void Acoustics Research Ltd,

Unit L, The Fulcrum

Vantage Way

Poole

BH12 4NU

United Kingdom

Call: +44(0) 1202 666006

Email: hello@voidacoustics.com



Hear. Feel. Connect.

voidacoustics.com