

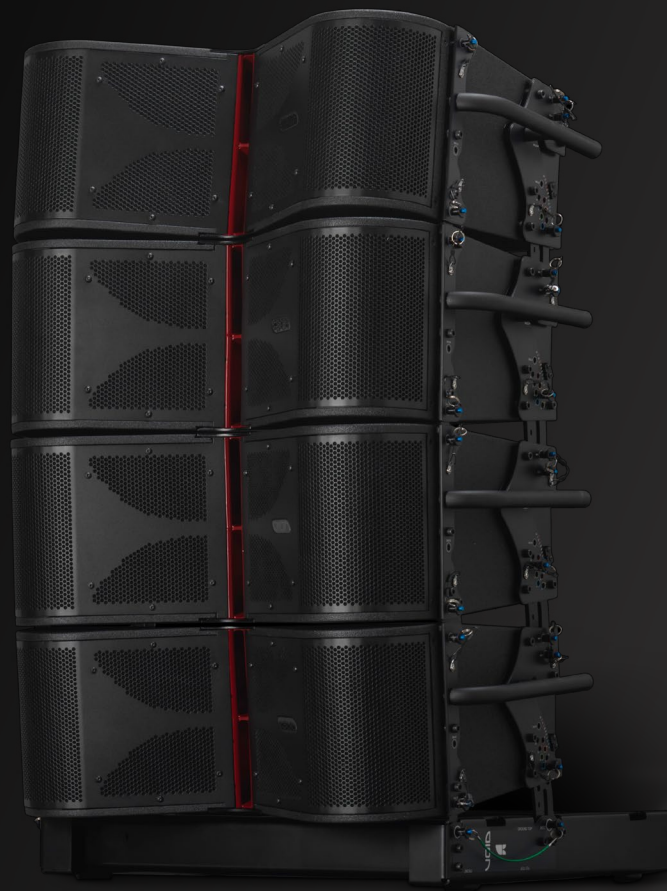

Hear. Feel. Connect.

voidacoustics.com



Arcline 8/212

Attractive composition, exceptional power

USER GUIDE V2.2

©2025 Void Acoustics Research Ltd.

This user guide is subject to change without notice.
For the latest online version, visit: www.voidacoustics.com

Void Acoustics and the Void logo are registered trademarks of Void Acoustics Research Ltd. in the United Kingdom, USA and other countries; all other Void trademarks are the property of Void Acoustics Research Ltd.

Contents

| | | | | | |
|----------|--|-----------|------------|--|-----------|
| 1 | Safety and Regulations | 4 | 6.3 | Typical Flying Procedure | 24 |
| 1.1 | Important Safety Instructions | 4 | 6.4 | Stacking | 29 |
| 1.2 | Limitations | 4 | | | |
| 1.3 | EC Declaration of Conformity | 4 | 7 | Typical Configurations | 32 |
| 1.4 | UKCA Conformity | 4 | 7.1 | Stacking | 32 |
| 1.5 | Warranty Statement | 4 | 7.2 | Flying Arcline 8 | 33 |
| 1.6 | WEEE Directive | 4 | 7.3 | Flying Arcline 8 with Arcline 212 | 33 |
| 2 | Unpacking and Checking | 5 | 8 | Service | 34 |
| 3 | About | 6 | 8.1 | Return Authorisation | 34 |
| 3.1 | Welcome | 6 | 8.2 | Shipping and Packing Considerations | 34 |
| 3.2 | Arcline 8 | 6 | 9 | Appendix A - Accessories | 35 |
| 3.2.1 | Overview | 6 | 9 | Appendix B - Connectors and Cabling | 36 |
| 3.2.2 | Key Features | 6 | 9 | Appendix C - Architectural Specifications | 38 |
| 3.2.3 | Arcline 8 Specifications | 7 | | | |
| 3.2.4 | Arcline 8 Dimensions | 8 | | | |
| 3.3 | Arcline 212 | 9 | | | |
| 3.3.1 | Overview | 9 | | | |
| 3.3.2 | Key Features | 9 | | | |
| 3.3.3 | Arcline 212 Specifications | 9 | | | |
| 3.3.4 | Arcline 212 Dimensions | 10 | | | |
| 3.4 | System Compliance | 11 | | | |
| 4 | Cable and Wiring | 12 | | | |
| 4.1 | Electrical Safety | 12 | | | |
| 4.2 | Cable Considerations for Fixed Installations | 12 | | | |
| 4.3 | Arcline 8 Wiring Diagram | 13 | | | |
| 4.4 | Arcline 212 Wiring Diagram | 13 | | | |
| 4.5 | Arcline 8 Bias Q5 speakON™ wiring | 14 | | | |
| 4.6 | Arcline 212 Bias Q5 speakON™ wiring | 15 | | | |
| 5 | Amplification and Control | 16 | | | |
| 5.1 | System Control Using Armonia software | 16 | | | |
| 6 | Flying and Stacking | 17 | | | |
| 6.1 | Arcline Rigging Components and key Features | 17 | | | |
| 6.1.1 | Arcline Fly Frame | 17 | | | |
| 6.1.2 | Laser/Inclinometer | 18 | | | |
| 6.1.3 | Arcline 8 | 19 | | | |
| 6.1.4 | Arcline 212 | 22 | | | |
| 6.2 | Rigging Safety | 24 | | | |

1 Safety and Regulations

1.1 Important safety instructions



The lightning flash with an arrowhead symbol within an equilateral triangle is intended to alert the user to the presence of uninsulated "dangerous voltage" within the product's enclosure that may be of sufficient magnitude to constitute a risk of electric shock to persons.



The exclamation point within an equilateral triangle is intended to alert the user of the presence of important operating and maintenance (servicing) instructions in the literature accompanying the appliance.

Safety instructions - read this first

1. Read these instructions.
2. Keep these instructions.
3. Heed all warnings.
4. Follow all instructions.
5. Do not use this apparatus near water.
6. Clean only with a dry cloth.
7. Do not block any ventilation openings. Install in accordance with the manufacturer's instructions.
8. Do not install near any heat source such as radiators, heat registers, stoves, or other such apparatus that produce heat.
9. Do not defeat the safety purpose of the grounding-type plug. A grounding type plug has two blades and a third grounding prong. The third prong is provided for your safety. If the provided plug does not fit into your outlet, consult an electrician for replacement of the obsolete outlet.
10. Protect power cords from being walked on or pinched particularly at plugs, convenience receptacles, and the point where they exit the apparatus.
11. Only use attachments and accessories specified by Void Acoustics.
12. Only use with the cart, stand, tripod, bracket, or table specified by the manufacturer, or sold with the apparatus. When a cart is used, use caution when moving the cart/apparatus combination to avoid injury from tip-over.
13. Unplug the apparatus during lightning storms or when unused for long periods of time.
14. Refer all servicing to qualified service personnel. Servicing is required when the apparatus has been damaged in any way, such as when the power-supply cord or plug is damaged, liquid has been spilled or objects have fallen into the apparatus, the apparatus has been exposed to rain or moisture, does not operate normally, or has been dropped.
15. Since the mains power supply cord attachment plug is used to disconnect the device, the plug should always be easily accessible.
16. Void loudspeakers can produce sound levels capable of causing permanent hearing damage from prolonged exposure. The higher the sound level, the less exposure needed to cause such damage. Avoid prolonged exposure to the high sound levels from the loudspeaker.

1.2 Limitations

This guide is provided to help familiarise the user with the loudspeaker system and its accessories. It is not intended to provide comprehensive electrical, fire, mechanical and noise training and is not a substitute for industry-approved training. Nor does this guide absolve the user of their obligation to comply with all relevant safety legislation and codes of practice. While every care has been taken in creating this guide, safety is user-dependent and Void Acoustics Research Ltd cannot guarantee complete safety whenever the system is rigged and operated.

1.3 EC declaration of conformity

For EC Declaration of Conformity please go to:

www.voidacoustics.com/eu-declaration-loudspeakers

1.4 UKCA marking

For details of the UKCA marking go to:

www.voidacoustics.com/uk-declaration-loudspeakers

1.5 Warranty statement

For warranty statement go to:

<https://voidacoustics.com/terms-conditions/>

1.6 WEEE directive

If the time arises to throw away your product, please recycle all the components possible.



This symbol indicates that when the end-user wishes to discard this product, it must be sent to separate collection facilities for recovery and recycling. By separating this product from other household-type waste, the volume of waste sent to incinerators or land-fills will be reduced and natural resources will thus be conserved.

The Waste Electrical and Electronic Equipment Directive (WEEE Directive) aims to minimise the impact of electrical and electronic goods on the environment. Void Acoustics Research Ltd complies with the Directive 2002/96/EC and 2003/108/EC of the European Parliament on waste electrical finance the cost of treatment and recovery of electronic equipment (WEEE) in order to reduce the amount of WEEE that is being disposed of in land-fill sites. All of our products are marked with the WEEE symbol; this indicates that this product must NOT be disposed of with other waste. Instead it is the user's responsibility to dispose of their waste electrical and electronic equipment by handing it over to an approved reprocessor, or by returning it to Void Acoustics Research Ltd for reprocessing. For more information about where you can send your waste equipment for recycling, please contact Void Acoustics Research Ltd or one of your local distributors.



2 Unpacking and Checking

All Void Acoustics products are carefully manufactured and thoroughly tested before being despatched. Your dealer will ensure that your Void products are in pristine condition before being forwarded to you but mistakes and accidents can happen.

Before signing for your delivery:

- Inspect your shipment for any signs of contamination, abuse or transit damage as soon as you receive it
- Check your Void Acoustics delivery fully against your order
- If your shipment is incomplete or any of its contents are found to be damaged; inform the shipping company and inform your dealer.

Arcline loudspeakers are heavy and require a minimum two people to lift.

- Undo the four butterfly catches on the transport case then remove the lid making sure the lid is clear before moving sideways
- If you need to place the Arcline on a flat surface ensure you use a lint free product to protect the finish
- When removing the Arcline take care not to damage the lower tray of the transport case.

Keep the original packaging in case you need to return a product for service later.

See section 1.5 for warranty conditions and see section 9 if your product needs servicing.

3 About

3.1 Welcome

Many thanks for purchasing this Void Acoustics Arcline Series product. We truly appreciate your support. At Void, we design, manufacture and distribute advanced professional audio systems for the installed and live sound market sectors. Like all Void products, our highly skilled and experienced engineers have successfully combined pioneering technologies with groundbreaking design aesthetics, to bring you superior sound quality and visual innovation. In buying this product, you are now part of the Void family and we hope using it brings you years of satisfaction. This guide will help you both use this product safely and ensure it performs to its full capability.

3.2 Arcline 8

3.2.1 Overview

A host of new technologies dramatically improve the perceived sound quality and definition of the Arcline 8, while an advanced rigging system reduces setup time and the need for more than one person to rig multiple enclosures. Delivering a true 110-degree dispersion results in a highly uniform polar pattern, bringing uniform sound quality across the entire sound field.

The high frequency horn design optimises the waveguide and a new phase shading device allows multiple Arcline 8 enclosures to form a true cylindrical wavefront by splitting two acoustic sources into four, with the acoustic centre positioned optimally for coupling. Rigging angles can also be pre-selected before flying the system.

3.2.2 Key features

- Two-way active, three-way line array module
- 110° horizontal dispersion
- True cylindrical wavefront
- 2 x 8" mid transducers with phase devices
- 2 x 8" horn loaded low frequency transducers
- 2 x 1.4" compression drivers
- Rigging angle pre-selected before lifting the enclosures
- Ground stackable

3 About

3.2.3 Arcline 8 specifications

| | |
|-----------------------------|--|
| Frequency response | 110 Hz - 20 kHz single enclosure, 90 Hz - 20 kHz three enclosures ± 3 dB |
| Efficiency ¹ | LF: 97 dB (100 dB referenced to 1 W) MF/HF: 103 dB (106 dB referenced to 1 W) |
| Crossover points | LF: 110 Hz - 300 Hz, HMF: 300 Hz - passive 1.2 kHz |
| Nominal impedance | 2 x 16 Ω |
| Power handling ² | LF: 500 W AES, HF: 500 W AES |
| Maximum output ³ | 128 dB cont, 145 dB peak |
| Driver configuration | 2 x 1.4" compression drivers 2 x 8" mid drivers with phase device 2 x 8" horn loaded low frequency drivers |
| Dispersion | 110°H x 12°V |
| Protection | Internal electronic control |
| Connectors | 2 x 4-pole speakON™ NL4 |
| Height | 285 mm (11.2") |
| Width | 881 mm (34.7") |
| Depth | 470 mm (18.5") |
| Weight | 39 kg (86 lbs) |
| Enclosure | 15 mm multi-laminate plywood |
| Rigging | Rigging angle pre selected before you lift the enclosures Ground stackable A2 stainless steel |
| Finish | Textured TourCoat polyurea |
| Grille | Perforated steel with foam filter |

¹ Measured in half space ² AES2 - 1984 compliant ³ Calculated

3 About

3.2.4 Arcline 8 dimensions

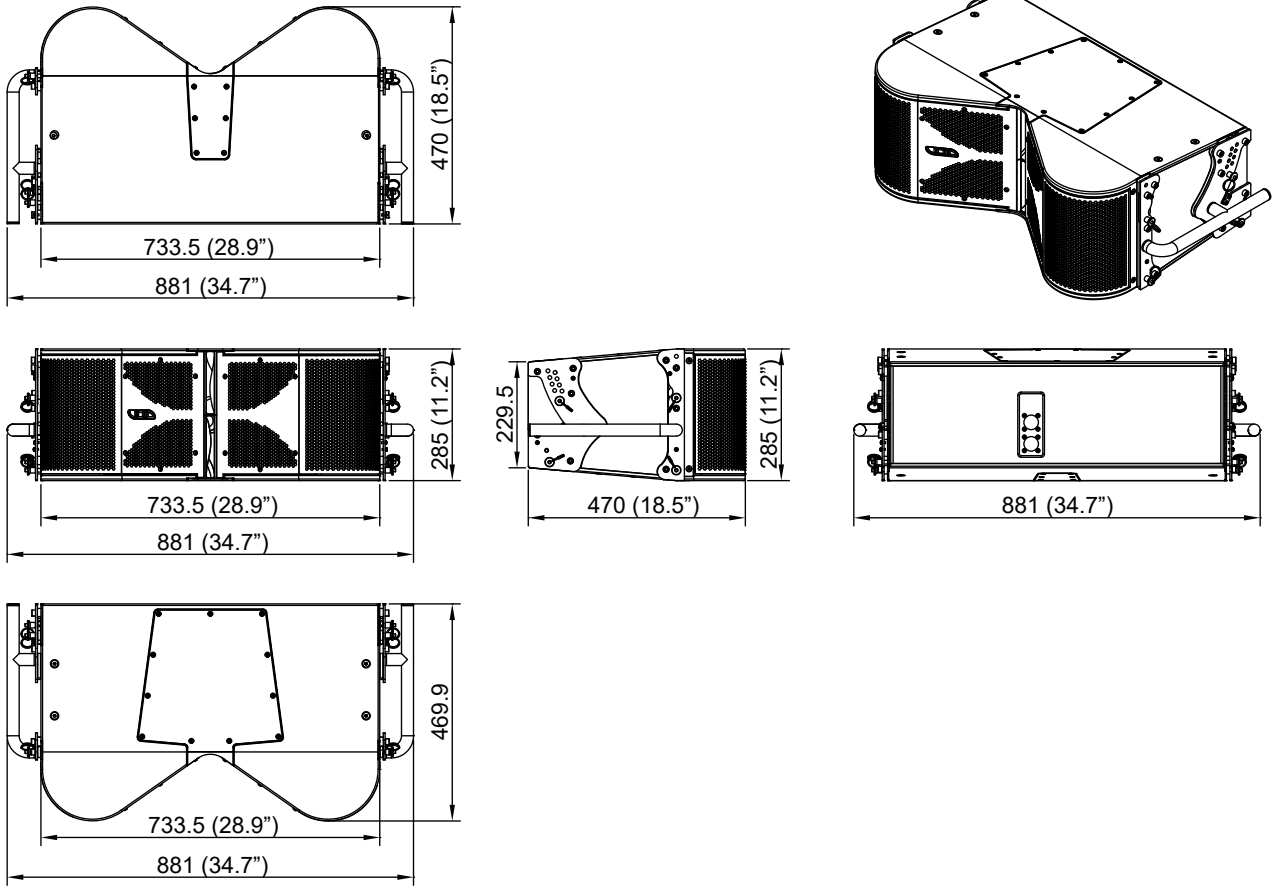

Figure 3.1: Arcline 8 dimensions

3 About

3.3 Arcline 212

3.3.1 Overview

Specially designed to extend the low frequency range of the Arcline line array, the Arcline 212 features two 12" 900 W low frequency drivers. This makes it possible to extend the frequency response range to as low as 50Hz, while also reaching up to 200Hz.

For ease, the Arcline 212 is flyable with the Arcline 8. It can be used in any application where suspended bass is required, including large venues and medium to large scale touring. Two Neutrik speakON™ NL4 connectors provide input and link through connections. Its lightweight birch plywood enclosure is finished in a textured TourCoat polyurea finish, bringing longevity for life on the road.

3.3.2 Key features

- Extended frequency range from 55 Hz to 120 Hz
- Flyable with Arcline 8
- Cardioid configuration integrated in the rigging
- FEA optimised porting

3.3.3 Arcline 212 specifications

| | |
|-----------------------------|--|
| Frequency response | 50 Hz to 200 Hz |
| Efficiency ¹ | 99 dB |
| Nominal impedance | 2 x 8 Ω |
| Power handling ² | 2 x 900 W AES |
| Maximum output ³ | 132 dB cont, 138 dB peak |
| Driver configuration | 2 x 12" low frequency drivers |
| Dispersion | Array dependent |
| Connectors | 2 x 4-pole speakON™ NL4 |
| Height | 367 mm (14.4") |
| Width | 877.5 mm (34.5") |
| Depth | 470 mm (18.5") |
| Weight | 42 kg (92.6 lbs) |
| Enclosure | 15 mm multi-laminate plywood |
| Rigging | A2 stainless steel rigging for use with Arcline 8 when flown or ground stacked |
| Finish | Textured TourCoat polyurea |
| Grille | Perforated steel with foam filter |

¹ Measured in half space ² AES2 - 1984 compliant ³ Calculated

3 About

3.3.4 Arcline 212 dimensions

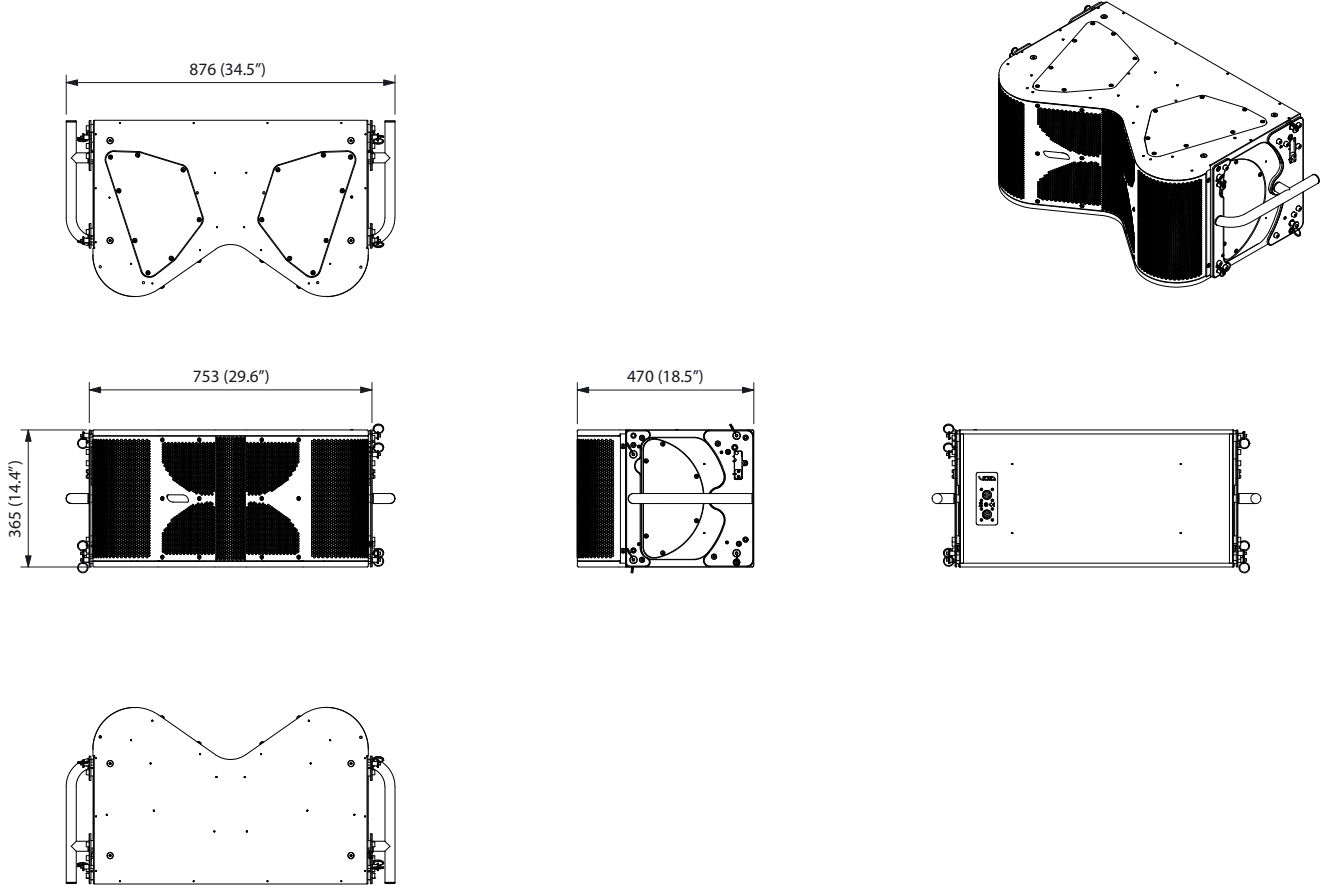

Figure 3.2: Arcline 212 dimensions

3 About

3.4 System compliance

| Product | Standards applied | Limitations of use |
|--|--------------------------------|---|
| Arcline 8 fly frame | BGV C1 | Conforms to BGV C1 for suspending: 12 Arcline 8 line-array elements |
| | BS7906-1 Category A | Conforms to BS7906-1 Category A for suspending: 12 Arcline 8 line-array elements |
| | BGV D8 and BS7906-1 Category B | Conforms to BGV D8 and BS7906-1 Category B for suspending: 12 Arcline 8 line-array elements as a static load with secondary suspension |
| Arcline 8 line-array element suspension system | BGV C1 | Conforms to BGV C1 for suspending: 12 Arcline 8 line-array elements |
| | BS7906-1 Category A | Conforms to BS7906-1 Category A for suspending: 12 Arcline 8 line-array elements as a dynamic load without secondary suspension |
| | BGV D8 and BS7906-1 Category B | Conforms to BGV D8 and BS7906-1 Category B for suspending: 12 Arcline 8 line-array elements as a static load with secondary suspension |
| Arcline 212 fly frame | BGV C1 | Conforms to BGV C1 for suspending: 12 Arcline 212 line-array elements |
| | BS7906-1 Category A | Conforms to BS7906-1 Category A for suspending: 12 Arcline 212 line-array elements |
| | BGV D8 and BS7906-1 Category B | Conforms to BGV D8 and BS7906-1 Category B for suspending: 12 Arcline 212 line-array elements as a static load with secondary suspension |
| Arcline 212 line-array element suspension system | BGV C1 | Conforms to BGV C1 for suspending: 12 Arcline 212 line-array elements |
| | BS7906-1 Category A | Conforms to BS7906-1 Category A for suspending: 12 Arcline 212 line-array elements as a dynamic load without secondary suspension |
| | BGV D8 and BS7906-1 Category B | Conforms to BGV D8 and BS7906-1 Category B for suspending: 12 Arcline 212 line-array elements as a static load with secondary suspension |

Note: Must be safetied once in position.

4 Cable and Wiring

4.1 Electrical safety



To avoid electrical hazards please note the following:

- Only connect electrical equipment to 50-60 Hz AC power outlets rated at 100-120 VAC or 200-240 VAC
- Do not supply electrical power to equipment without a safety ground connection
- Do not supply electrical power to equipment that has been exposed to moisture (e.g. rain)
- Do not supply electrical power to equipment that has become coated in moisture (e.g. condensation)
- Do not access the inside of any electrical equipment. Refer servicing to Void-approved service agents.

4.2 Cable considerations for fixed installations

We recommend specifying installation-grade Low Smoke Zero Halogen (LSZH) cables for permanent installations. The cables should use Oxygen Free Copper (OFC) of grade C11000 or above. Cables for permanent installations should be compliant with the following standards:

- IEC 60332.1 Fire retardancy of a single cable
- IEC 60332.3C Fire retardancy of bunched cables
- IEC 60754.1 Amount of Halogen Gas Emissions
- IEC 60754.2 Degree of acidity of released gases
- IEC 61034.2 Measurement of smoke density.

We suggest using the following maximum copper cable lengths to keep level losses below 0.6 dB.

| Arcline cabinets in parallel | | 2 x Arcline 8 | 4 x Arcline 8 |
|------------------------------|--------------|-----------------|-----------------|
| | | 1 x Arcline 212 | 2 x Arcline 212 |
| Metric mm ² | Imperial AWG | 8 Ω load | 4 Ω Load |
| 2.5 mm ² | 13 AWG | 36 m | 18 m |
| 4 mm ² | 11 AWG | 60 m | 30 m |

4 Cable and Wiring

4.3 Arcline 8 wiring diagram

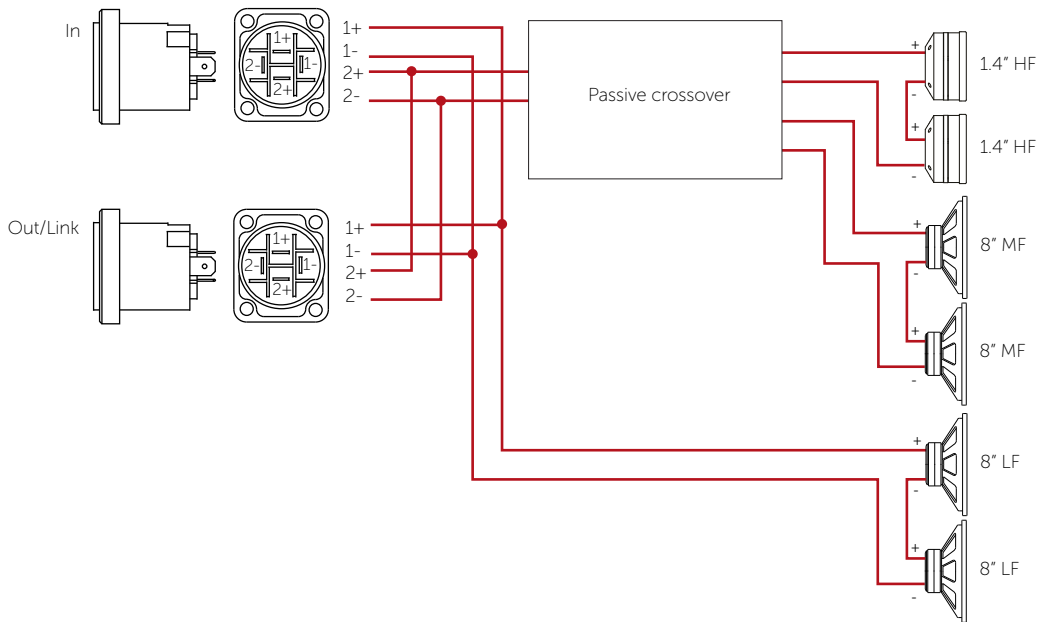

Figure 4.1: Arcline 8 wiring diagram

| | speakON™ pins 1+/1- | speakON™ pins 2+/2- |
|-----|---------------------|---------------------------|
| In | LF (2 x 8") | MHF (2 x 8" and 2 x 1.4") |
| Out | LF link | MHF link |

4.4 Arcline 212 wiring diagram

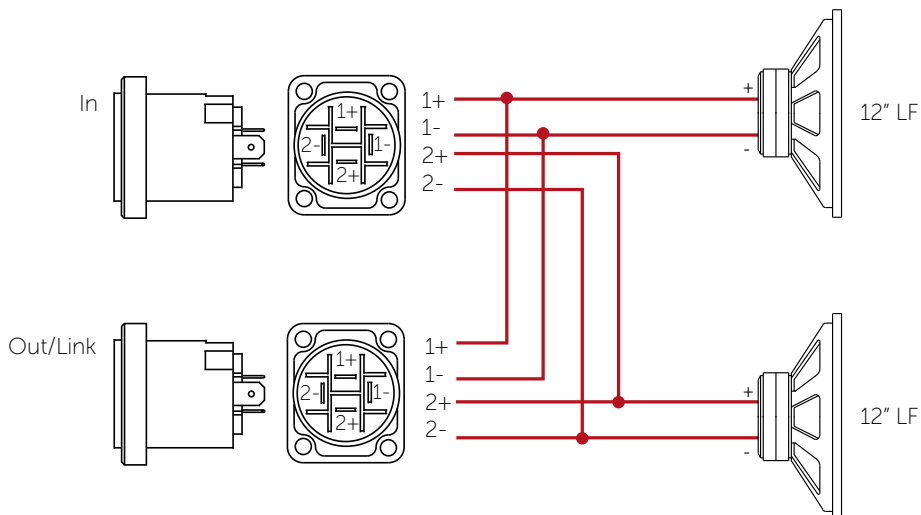

Figure 4.2: Arcline 212 wiring diagram

| | speakON™ pins 1+/1- | speakON™ pins 2+/2- |
|-----|---------------------|---------------------|
| In | LF (12") | LF (12") |
| Out | LF link | LF link |

4 Cable and Wiring

4.5 Arcline 8 Bias Q5 speakON™ wiring

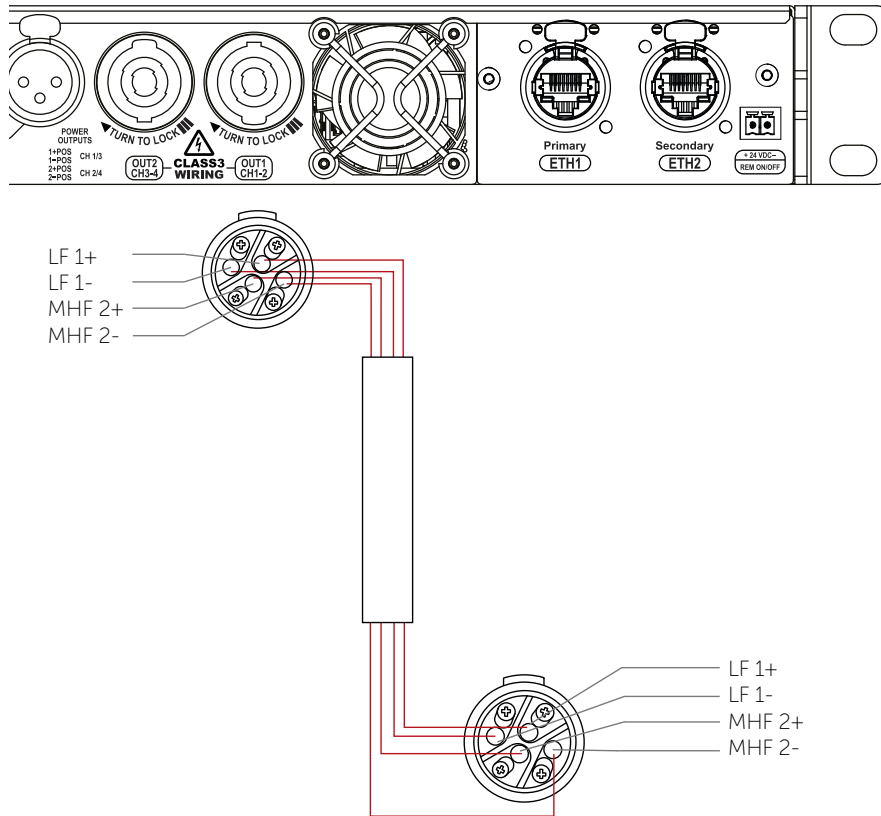

Figure 4.3: Arcline 8 Bias Q5 wiring

| Bias Q5 | Output 1 | Output 2 |
|---------|-------------|---------------------------|
| Output | LF (2 x 8") | MHF (2 x 8" and 2 x 1.4") |



Note that Q5 amplifier output channels do not share a common ground for "1-" and "2-"

- Avoid grounding Q5 amplifier outlet pins or loudspeaker connector pins
- Never wire loudspeaker installation panels with common Ch1 and Ch2 loudspeaker return lines

4 Cable and Wiring

4.6 Arcline 212 Bias Q5 speakON™ wiring

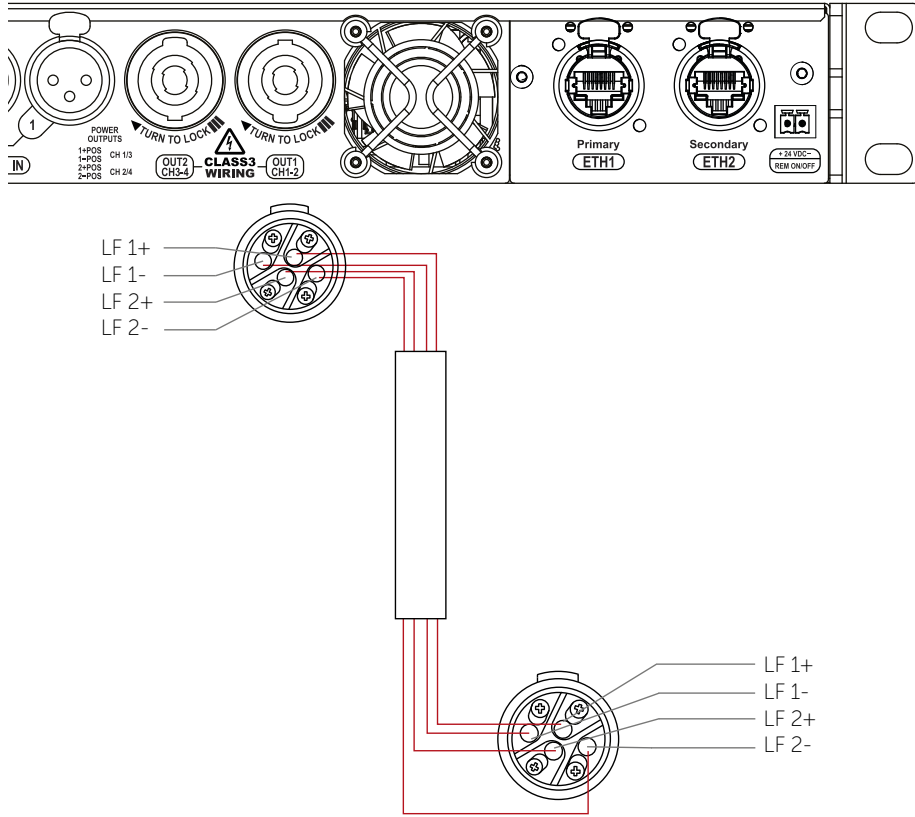

Figure 4.4: Arcline 212 Bias Q5 wiring

| | | |
|---------|----------|----------|
| Bias Q5 | Output 1 | Output 2 |
| Output | LF (12") | LF (12") |



Note that Q5 amplifier output channels do not share a common ground for "1-" and "2-"

- Avoid grounding Q5 amplifier outlet pins or loudspeaker connector pins
- Never wire loudspeaker installation panels with common Ch1 and Ch2 loudspeaker return lines

5 Amplification and Control

5.1 System control using Armonía software

Arcline systems are powered by Bias Q5 DSP power amplifiers that are controlled via Powersoft's Armonía Plus System Manager.

Armonía Plus System Manager software, updates and tutorials are provided via the www.powersoft-audio.com website as follows:

Armonía on-line support go to <https://armonia.powersoft.it/> for details

Ensure that all your Bias Q5 amplifiers are loaded with the same firmware version.

1. Different firmware versions on different amplifiers may lead to latency mismatches
2. Keeping your amplifier firmware up-to-date will ensure that your Bias Q5 amplifiers work with the latest version of Armonía Plus.



Figure 5.6: Armonía Plus workspace for a Void Arcline 8/Arcline 212/Arcline 218

Arcline presets and updates

All void prestes are available through the marketplace in Armonía Plus as well as the latest firmware updates.

6 Flying and Stacking

6.1 Arcline rigging components and key features

6.1.1 Arcline fly frame

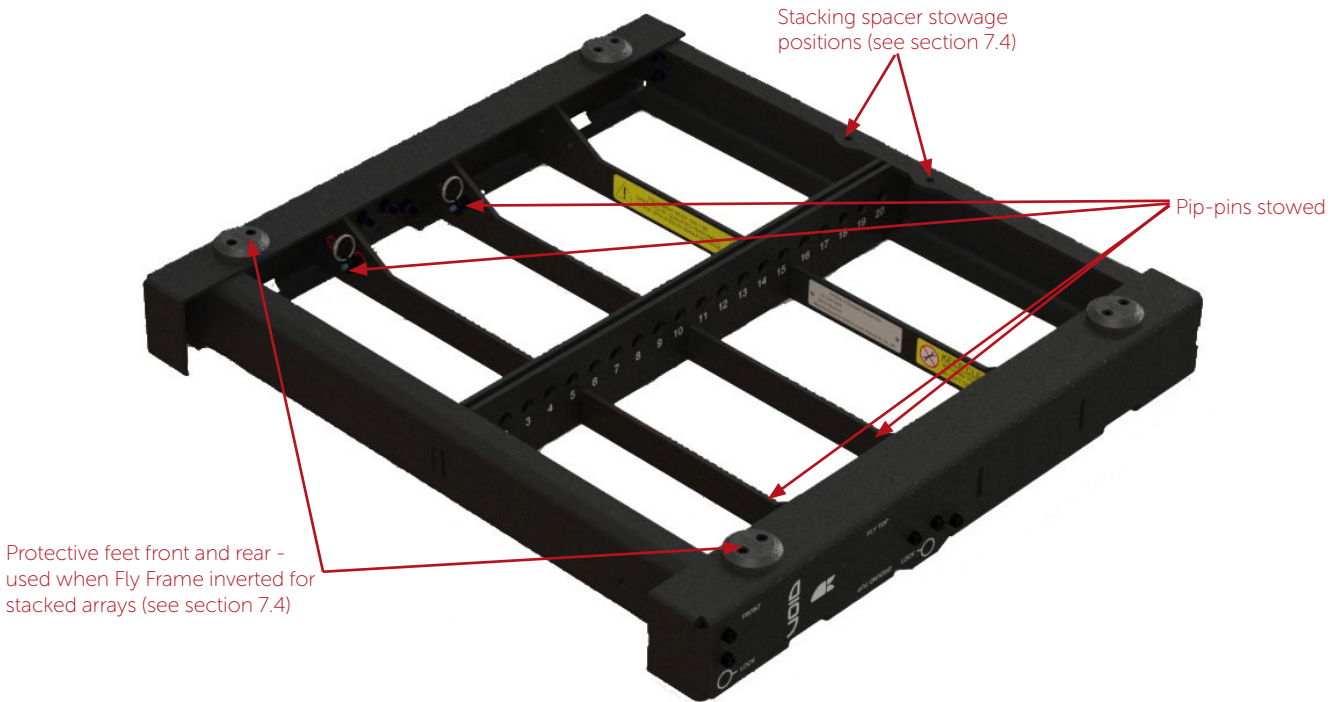

Figure 6.1: Void Arcline 8 Fly Frame looking from front right - shackles and pip-pins stowed for trucking (Top four protective feet used when Fly Frame inverted for stacking)



Note! The stowage positions should never be used as flying or safety points!

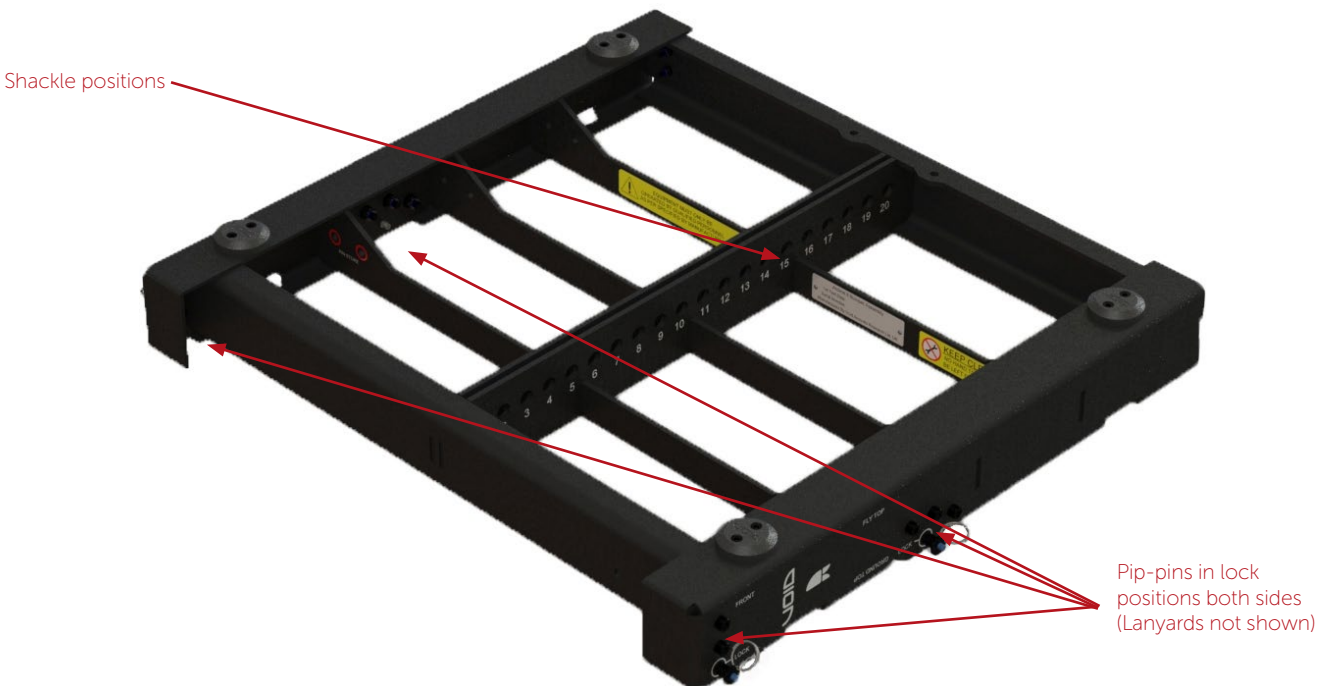

Figure 6.2: Void Arcline 8 Fly Frame looking from front left - shackles and pip-pins deployed

6 Flying and Stacking

6.1.2 Laser/inclinometer

Your Void Arcline flying system can be fitted with a Sigma Electronics Prosight2 Laser/inclinometer system for Fly Frame tilt angle verification and aiming.

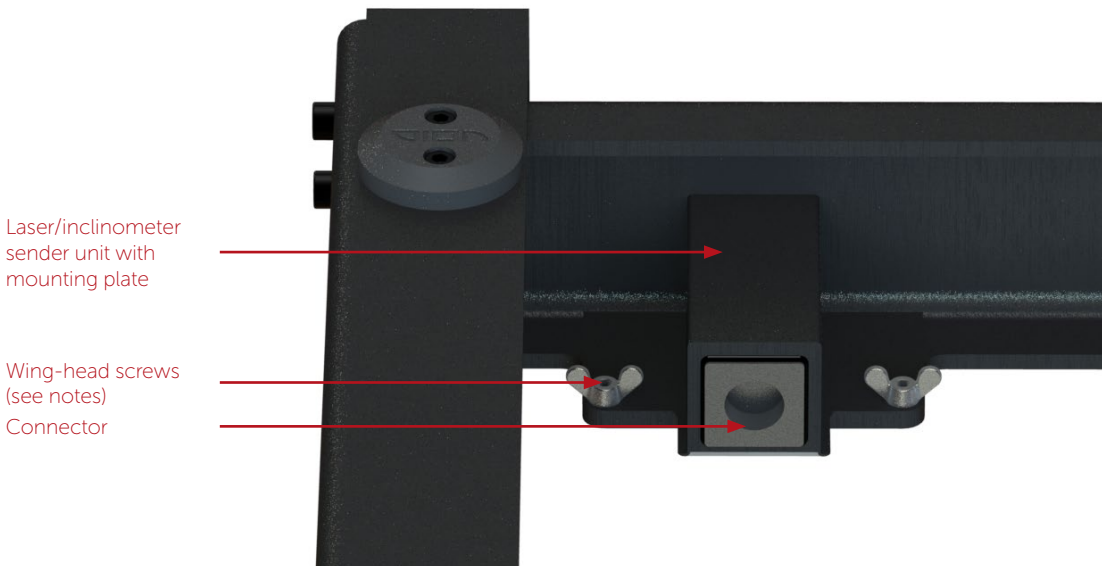

Figure 6.3: Void Arcline 8 Fly Frame laser/inclinometer sender unit mounting

Important notes:



- The sender unit must be fitted with a safety lanyard
- Thread-locking fluid must be used on the wing-head screw threads to prevent loosening.



Always observe laser safety precautions.

Click [here](#) to download the Prolight2 User Guide



Cabling

Data is transferred from the sender unit to the meter via a fully-populated (all pins connected) Cat5e cable with EtherCON connectors. The sender unit gets its power via this fully-populated Power over Ethernet (PoE) cable.

The laser/inclinometer's PoE cabling must NEVER be patched into your amplifier control network.

For further details, see - www.prosight2.co.uk

6 Flying and Stacking

6.1.3 Arcline 8

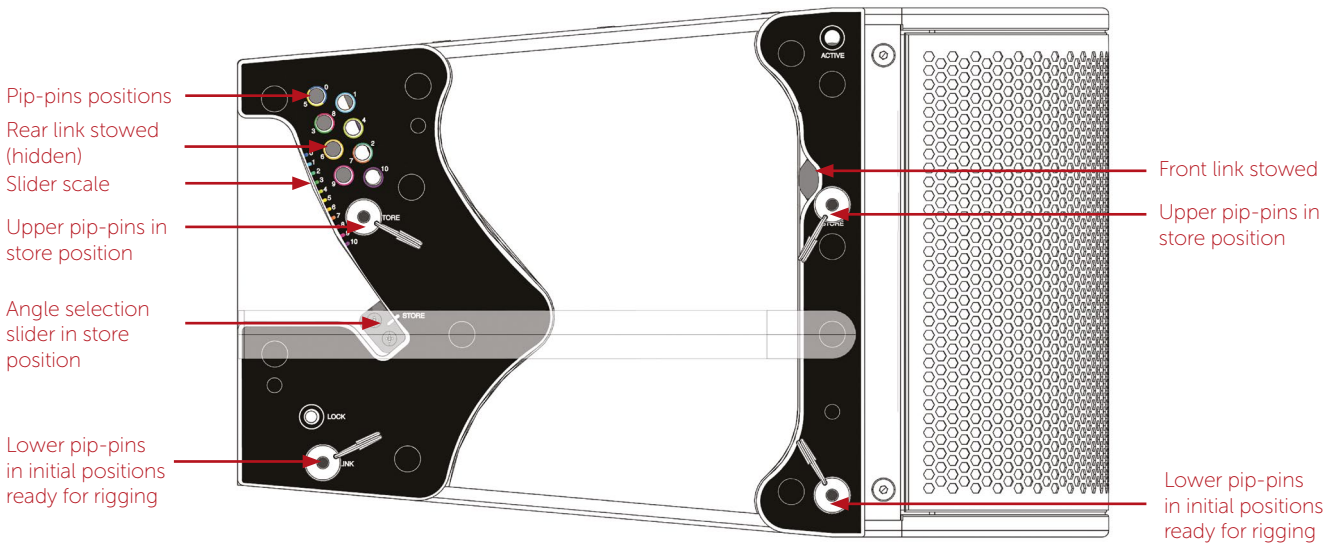

Figure 6.4: Void Arcline 8 left side view—links stowed

Note that Arcline 8 cabinets are usually trucked in groups of four, either cased straight (all set to 0°) to take up the minimum truck space or preset to the required inter-cabinet angle and cased tight-packed.

See information on rear link positions later.

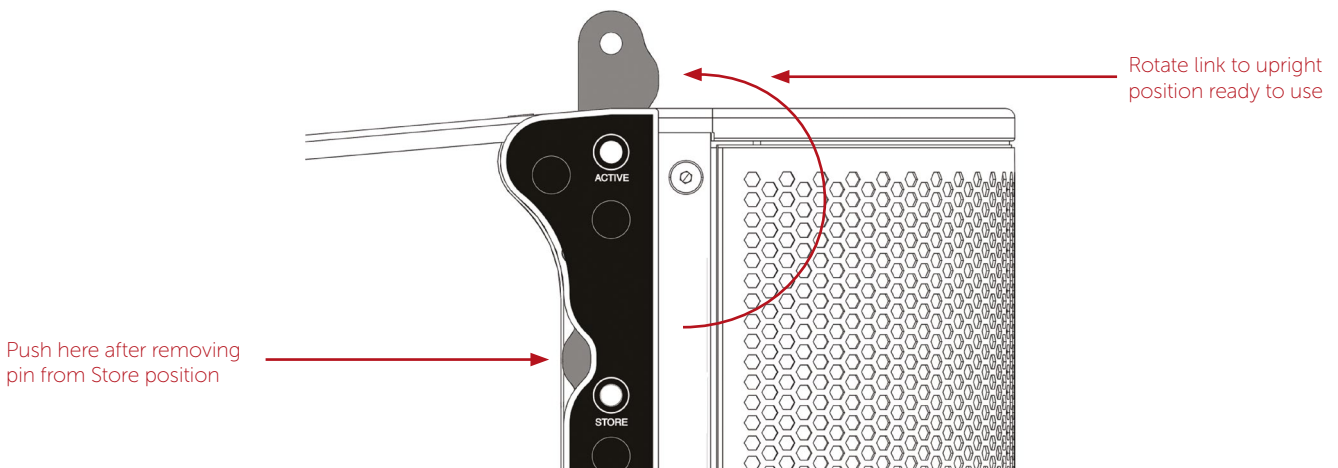

Figure 6.5: Void Arcline 8 front link deployment

Once the pip-pin is removed from the Store position, the link can easily be pushed forward to emerge from the front of the rigging mechanism. It may then be rotated to a vertical position ready for use.

6 Flying and Stacking

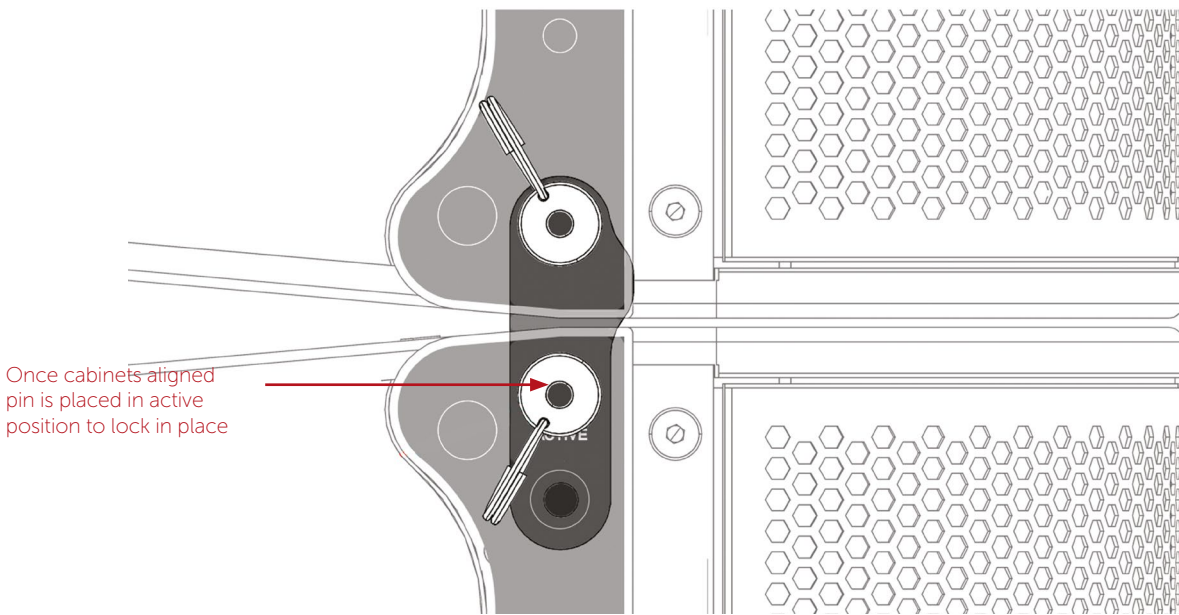

Figure 6.6: Front link pinned in Active position

Once upper and lower cabinets have been physically aligned and successfully linked, a pin is inserted into the Active position to maintain close coupling.

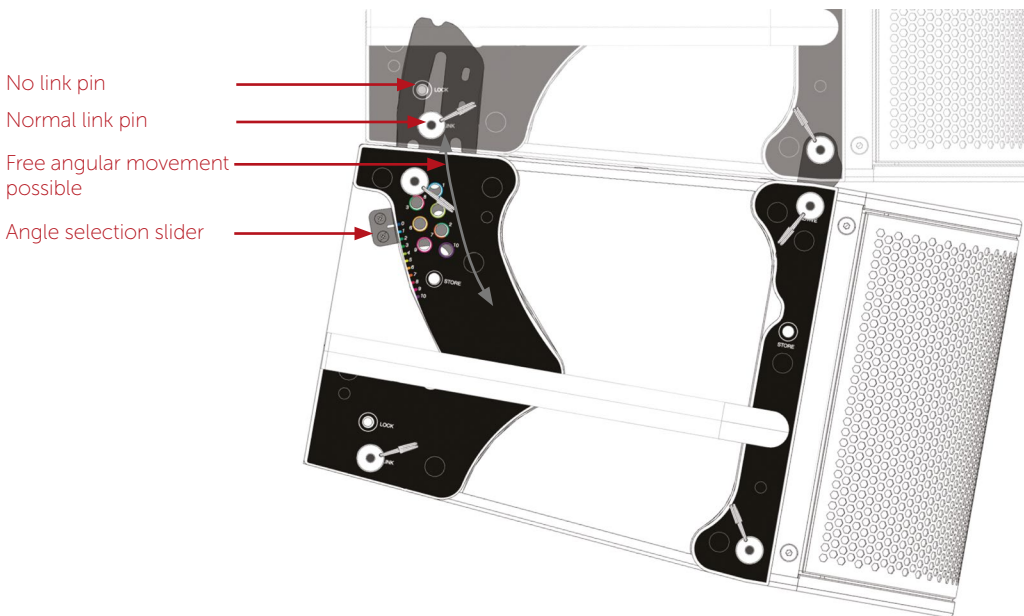

Figure 6.7: Rear link unlocked – cabinets tight-packed

When cabinets are linked together with only the rear Link pins, full angular movement is available due to the slotted rear link mechanism. Arcline 8 cabinets may be tight-packed – typically in groups of four – allowing all the inter-cabinet angles to be preset with the Angle Selection Slider and pre-pinned. This example shows two cabinets preset for a 0° splay angle. Groups of cabinets are usually raised at the rear (to tight-pack) and then lowered in a controlled way using a small chain hoist or lever hoist. See later.

6 Flying and Stacking

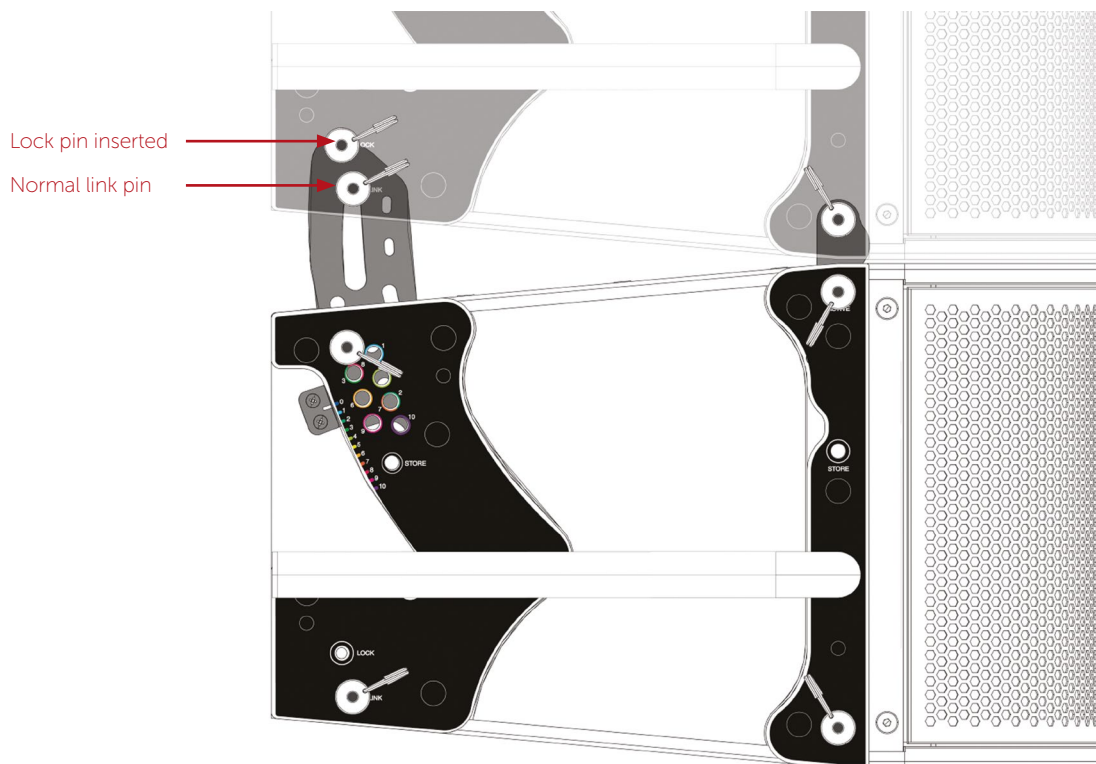
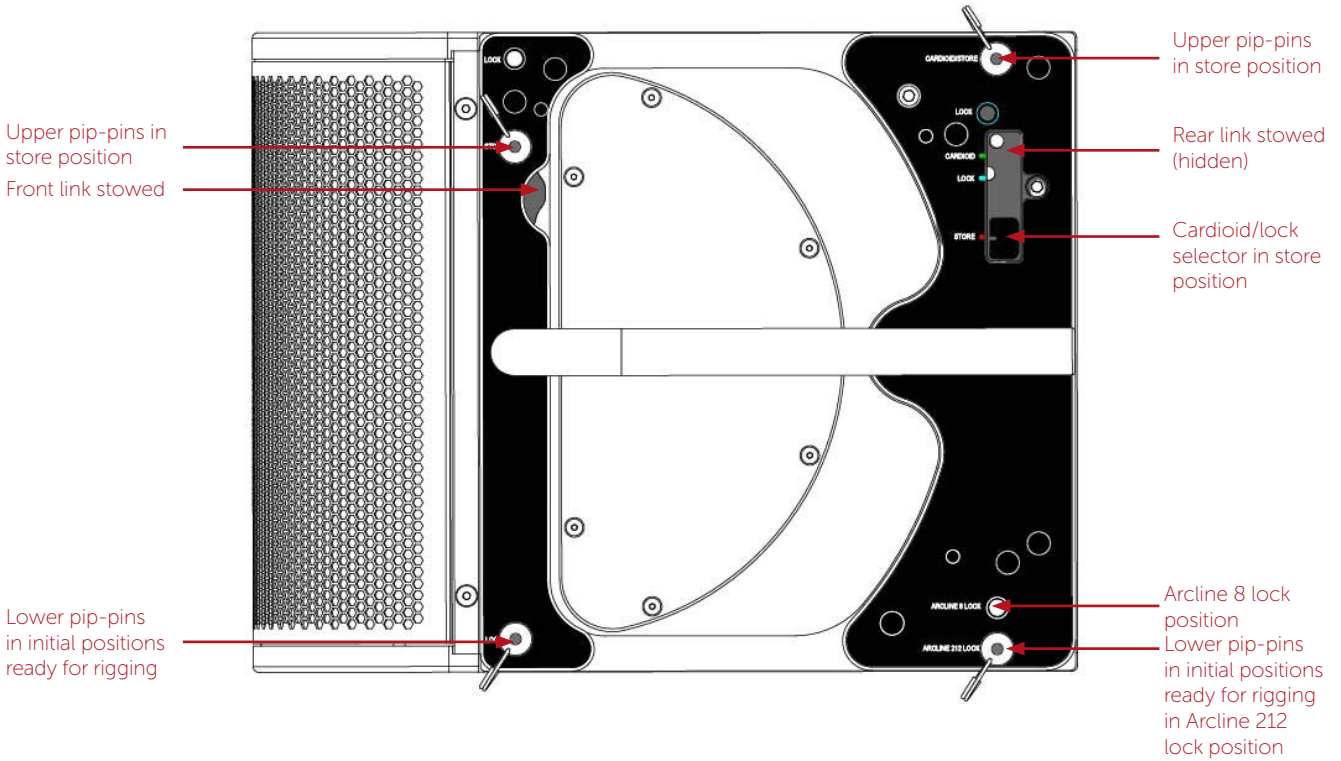

Figure 6.8: Rear of cabinet lowered and lock pin inserted

The preset angle is obtained once the bottom boxes are lowered and the normal link pin reaches the top of the rear link slot. An extra pin is now inserted into the lock position to prevent accidental array compression – when an array is up-tilted, for example.

6 Flying and Stacking

6.1.4 Arcline 212



Arcline 8 and Arcline 212 front link follows the same procedure. See section 7.1.3 above for instructions on fitting the front link and pip-pin.

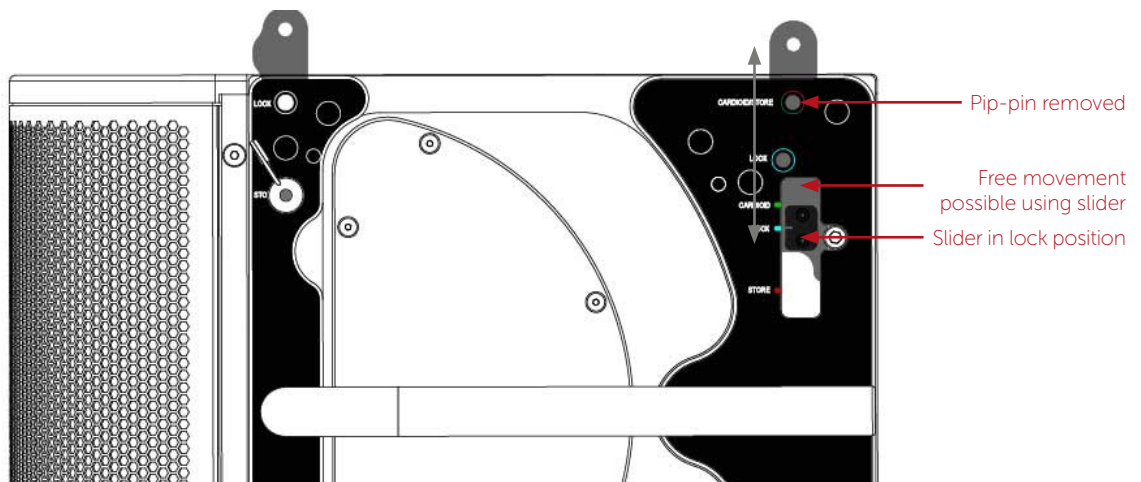

Removing the rear pip-pin allows the rear link to move freely. Use the slider to move the link into the desired position and insert the pip-pin into the relevant slot.

6 Flying and Stacking

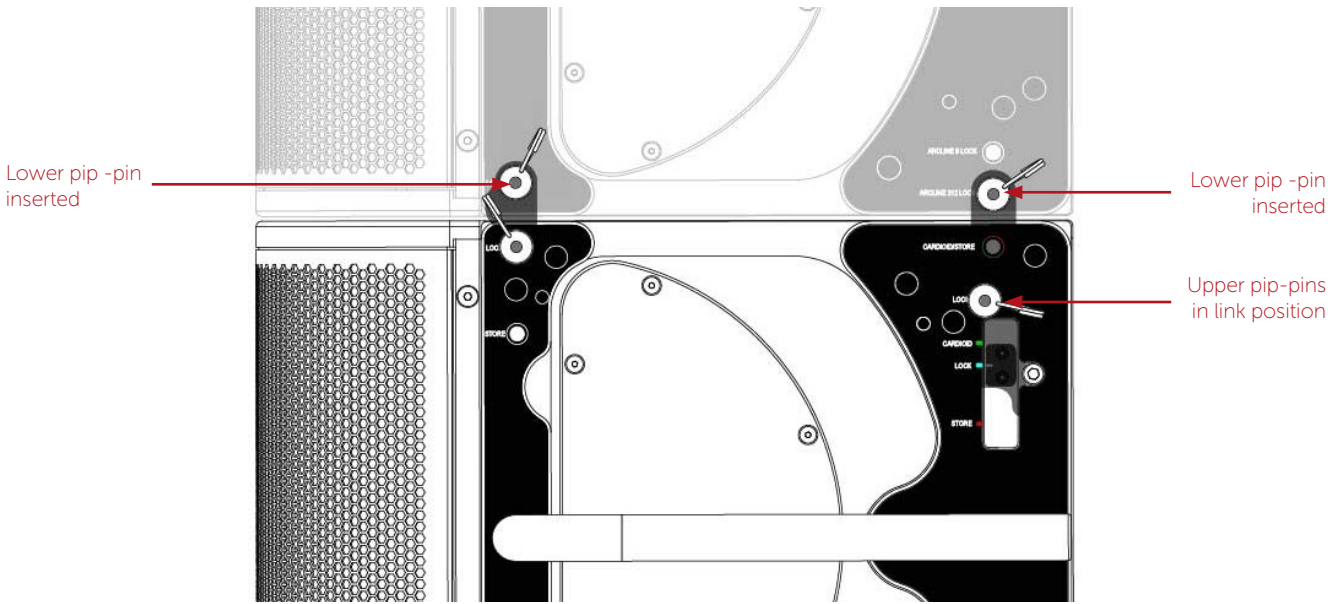

Once the cabinet is in position insert the lower pip-pins from the upper cabinet into the lock position. Note that for Arcline 8 use the upper lock position as shown above.

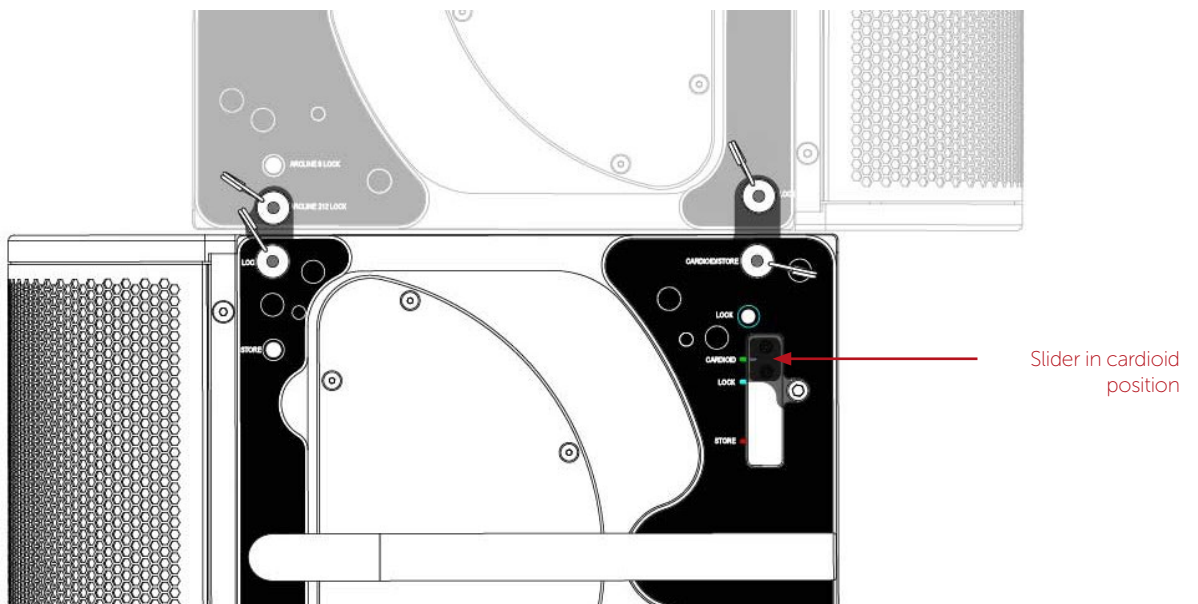

When deploying the Arcline 212 in cardioid configuration follow the same procedure but move the slider to the cardioid position and insert the pip-pin.

6 Flying and Stacking

6.2 Rigging safety



To avoid mechanical hazards, please note the following:

- Safety regulations vary in different regions. Full compliance with those regulations must be your priority
- Keep clear of rigging operations if you are tired, distracted, unwell or suffering from the effects or after-effects of medication, alcohol or drugs
- Rigging and stacking must only be undertaken by fully qualified and experienced riggers in full compliance with local, national and international regulations
- Remember that all personnel have a duty of care to themselves, to their assistants, to the venue staff and to the public
- Before lifting any part of the system above head height, check the whole rig for loose tools or other items that may fall and cause injury
- Ensure that you watch the rig and its motors during motor operations. Do not allow yourself to be distracted by inclinometer readings etc. The inclinometer meter may be checked each time the rig is stopped
- Do not use a telephone (even if hands-free) whilst rigging. Always concentrate fully on the rigging operation
- Do not rig equipment that is worn, damaged, corroded, mishandled or over-stressed in any way
- Do not fly more than 24 Arcline 8 cabinets
- Do not stack more than 6 Arcline 8 cabinets
- Use only Void-approved accessories.

6.3 Typical flying procedure

The Arcline Fly Frame allows arrays to be flown from single or dual lifting motors:

- A single motor pick-up complies with the single 1-tonne points found in many small to medium sized venues. Refer to the EASE Focus 3 system design software for the recommended Fly Frame pick-up hole number. (Section 6.1)
- Dual motor pick-up provides additional up/down tilt control. This makes rigging easier and provides horizontal aiming stability indoors. (Breezy outdoor conditions may still require stabilising guys)

6 Flying and Stacking

Typical flying sequence, once the Fly Frame has been flown and lowered

Once you have familiarised yourself with the key features of the Arcline 8 Fly Frame and cabinet rigging facilities (section 6.1), flying the system should be easy. Follow this sequence:

Assuming your Arcline 8 cabinets have been pre-linked and trucked in groups of four:

1. Attach the first four cabinets to the Fly Frame. (The top cabinet is set to 5° to be parallel to the Fly Frame)
2. Remove the rear Lock position pins
3. Double-pin the Arcline 8 bridle assembly (illustrated below) to the bottom cabinet's lower rear Lock & Link positions and attach a bridle to the bottom cabinet's lower rear pip-pin position
4. Then attach a temporary chain hoist or lever hoist between the bottom cabinet's rear bridle and the Void-supplied oval ring. (Note: the bridle is not a lifting device and is not intended to be used as a sole point of lifting)
5. Now temporarily tight-pack the array
6. Preset the inter-cabinet angles with the angle selection slider and pin the appropriately coloured angle hole.

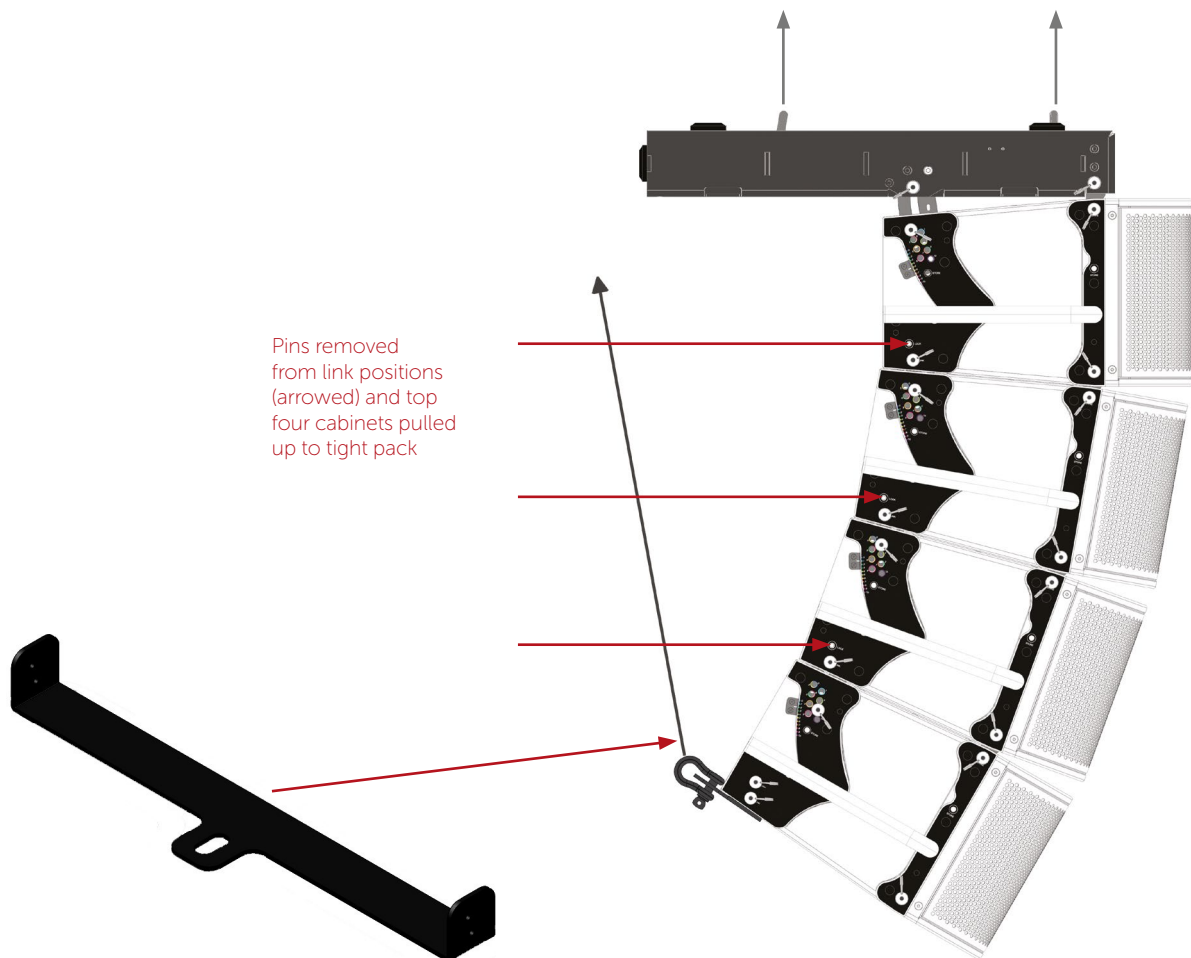

Figure 6.9: First four cabinets after steps 1 – 6 have been completed
Rear bridle assembly - attach to rear of bottom cabinet

6 Flying and Stacking

1. Gently release the hoist to allow the cabinets to take up their preset inter-cabinet angle positions
2. Replace the rear Lock position pins (arrowed in figure 8.10)
3. Remove the temporary chain hoist
4. Remove the rear bridle

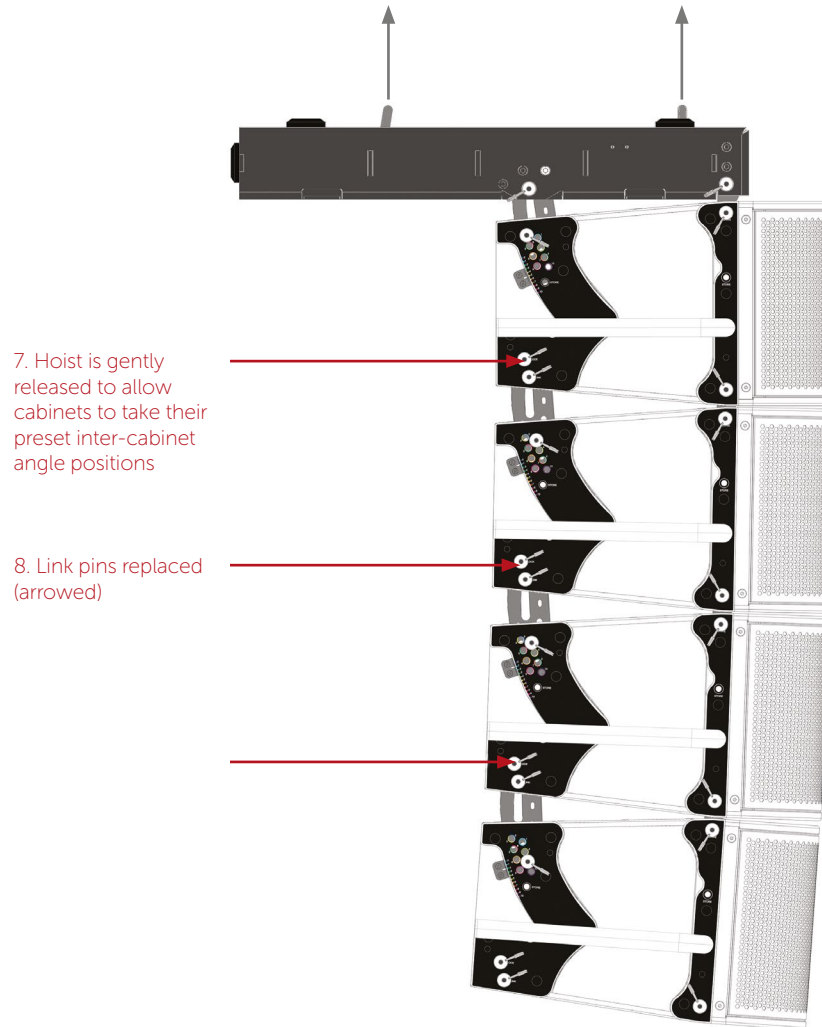

Figure 6.10 : Steps 7 – 10 have been completed and the chain hoist and rear bridle have been removed

6 Flying and Stacking

Further cabinets

The sequence may be repeated to increase the length of the array up to a maximum of 12 Arcline 8 cabinets.

Again, assuming your Arcline 8 cabinets have been pre-linked and trucked in groups of four, additional cabinets are added as follows:

1. Attach the next four cabinets to the ones above
2. Remove these next four cabinets' rear Lock position pins
3. Double-pin the Arcline 8 bridle assembly to the bottom cabinet's lower rear lock & link positions and attach a bridle (see previous page) to the bottom cabinet's lower rear pip-pin position
4. Again, attach a temporary chain hoist or lever hoist between the bottom cabinet's rear bridle and the Void-supplied oval ring. (Not visible in the illustration below but usually attached to a rear Fly Frame)
5. Now temporarily tight-pack the new four cabinets
6. Preset the inter-cabinet angles with the angle selection slider and pin the appropriately coloured angle hole

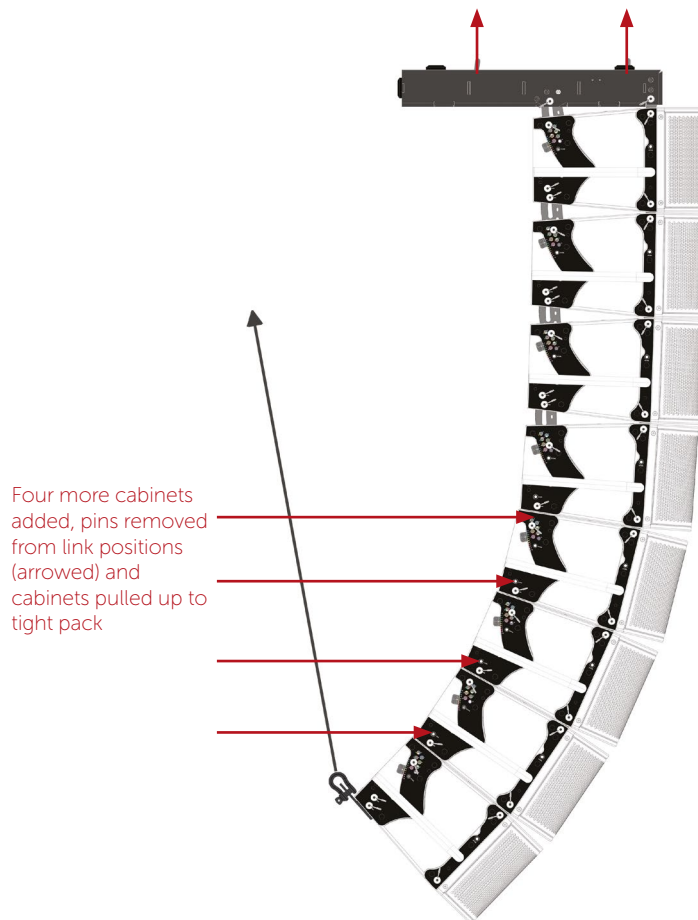

Figure 6.11: Steps 1 – 6 are repeated and another four cabinets are linked underneath, their Lock position pins removed and the extra four cabinets temporarily pulled back to a tight-pack configuration to allow angles to be preset

6 Flying and Stacking

1. Gently release the hoist to allow the cabinets to take up their preset inter-cabinet angle positions
2. Replace the rear lock position pins
3. Remove the temporary chain hoist
4. Remove the rear bridle.

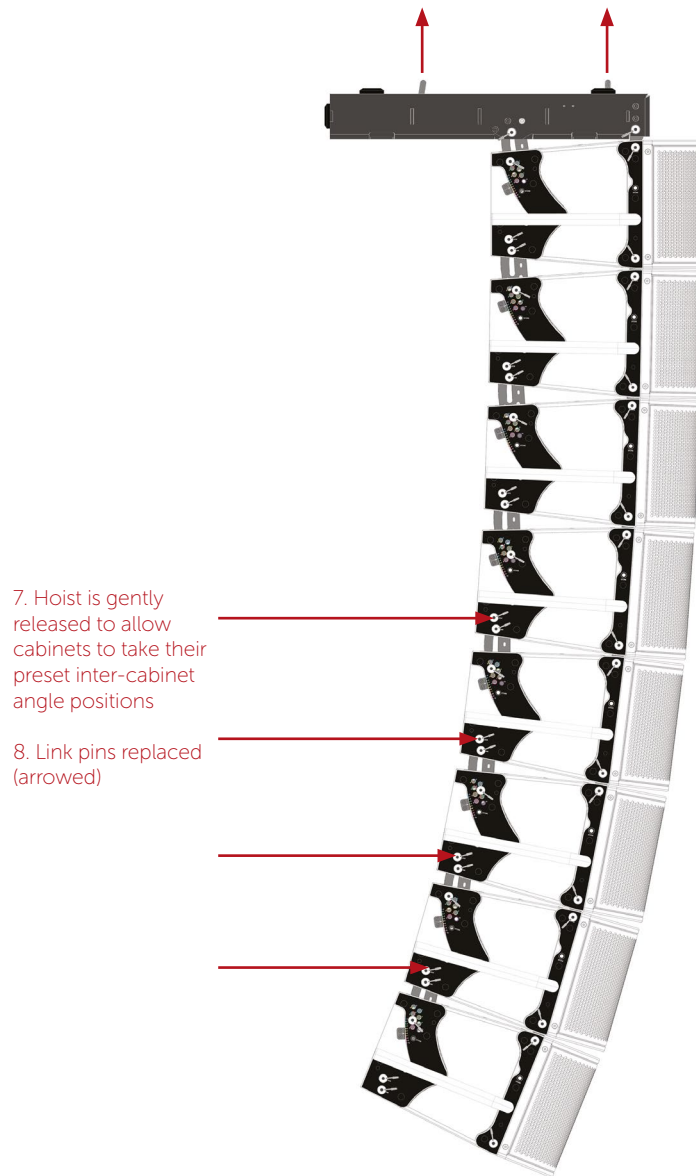

Figure 6.12: Steps 7 – 10 have been completed and the chain hoist and bridle have been removed

6 Flying and Stacking

6.4 Stacking



Important stacking safety notes

You are advised to employ a qualified rigger for system stacking

- Do not stack Arcline 8 systems more than six cabinets high
- Always stack on a solid mounting base
- Your Arcline 8 stack must be safety-tethered to a solid and well-anchored structure with the strength to prevent the array from toppling over if tilted well beyond its tipping point
- Safety tethering should provide a 5:1 load-bearing safety margin
- Do not tether to scaffolding unless it has been specifically designed and ballasted for the purpose
- When designing stacked Arcline 8 arrays, always use EASE Focus 3 with the latest approved Arcline 8 System definition (GLL) file installed – and ensure you make things safe if presented with warnings
- Ensure that EASE Focus 3 confirms that your Arcline 8 stack's centre-of-gravity (CoG) at least 150 mm behind the front of the inverted Fly Frame
- Ensure that safety barriers are installed between the stack and the venue staff, audience and crew. The space between safety barrier and array must be at least the array height +20%.

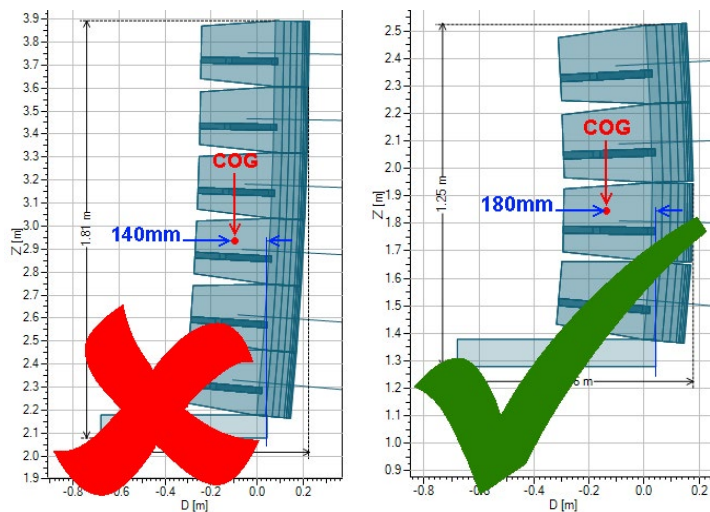

Figure 6.13: Arcline 8 stack centre-of-gravity

6 Flying and Stacking

Stacking your Arcline 8 system

The Arcline 8 Fly Frame and Arcline 8 cabinets are inverted for stacking. Think of an Arcline 8 stack as a completely inverted array (below).

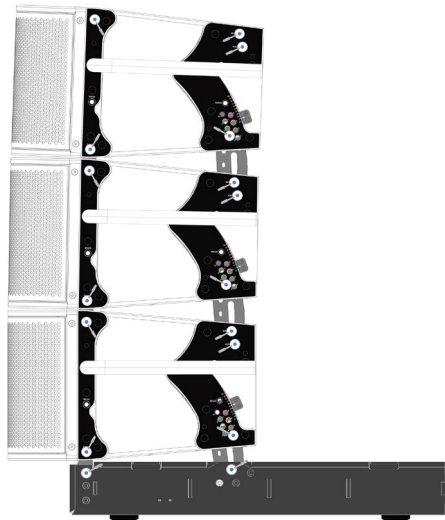

Figure 6.14: Arcline 8 stack showing inverted Fly Frame and cabinets

Stacking spacer

Steeper tilts may be required if the system is stacked on a high stage wing or a tall stack of subwoofers.

Mirror-image stacking spacers are available to provide an extra 10° of tilt when required.

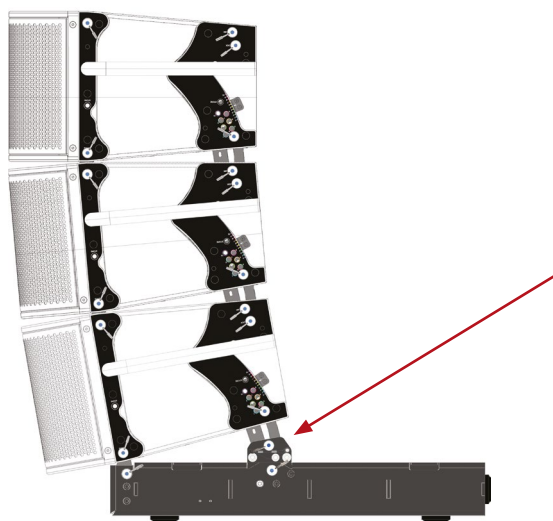

Figure 6.15: Arcline 8 stack showing stacking spacers

The stacking spacers fit between the lower Arcline 8's rear arms and the Fly Frame (arrowed above).

6 Flying and Stacking

The spacers slot into rear cabinet arm sockets on the inverted Fly Frame

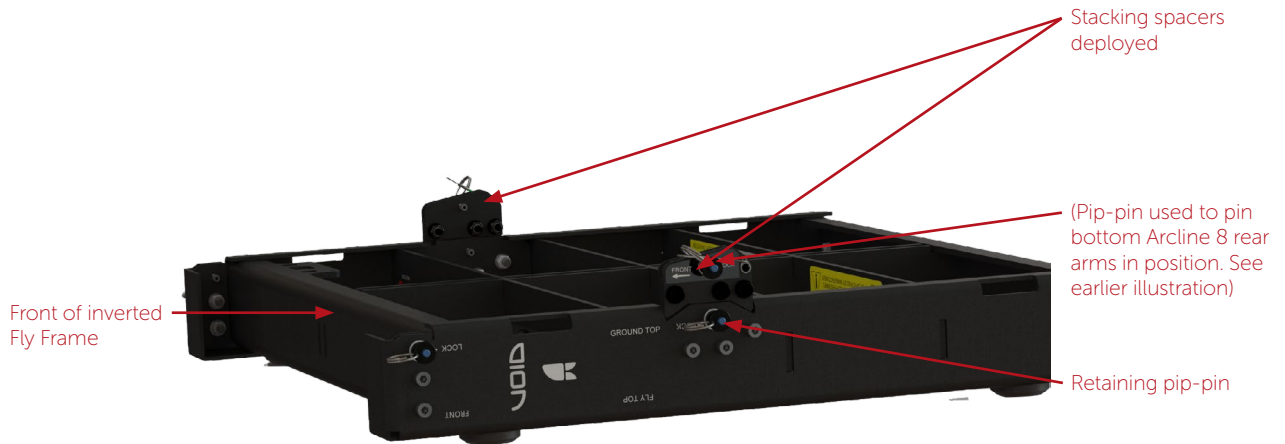

Figure 6.16: Stacking spacers shown deployed and ready for use

The stacking spacers may be stowed at the rear centre of the Fly Frame for transportation.

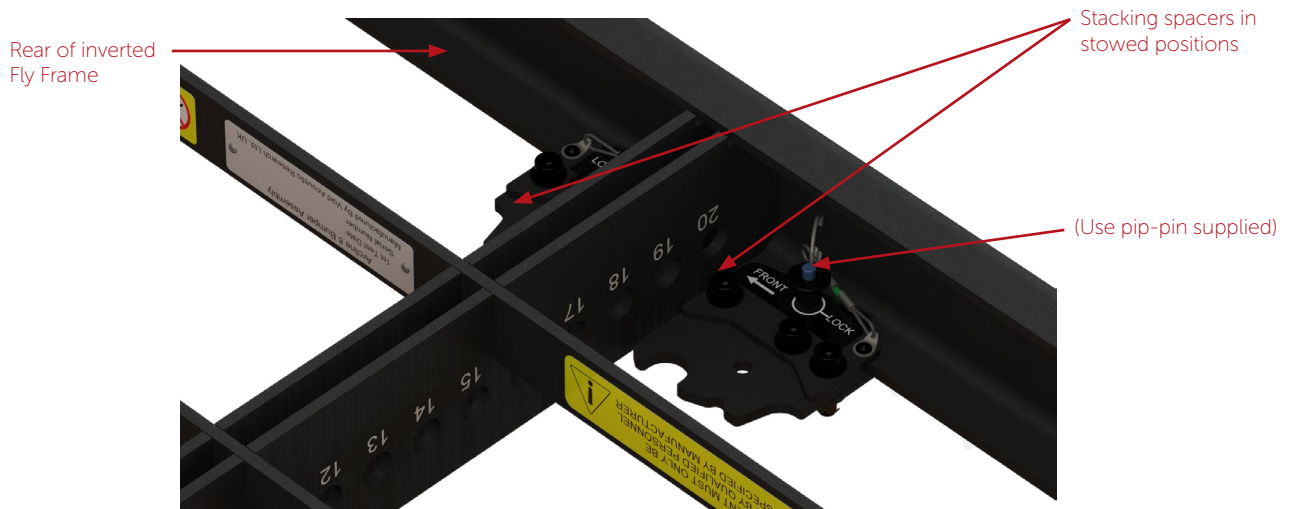

Figure 6.17: Stacking spacers in stowed position for transportation

7 Typical Configurations

7.1 Stacking

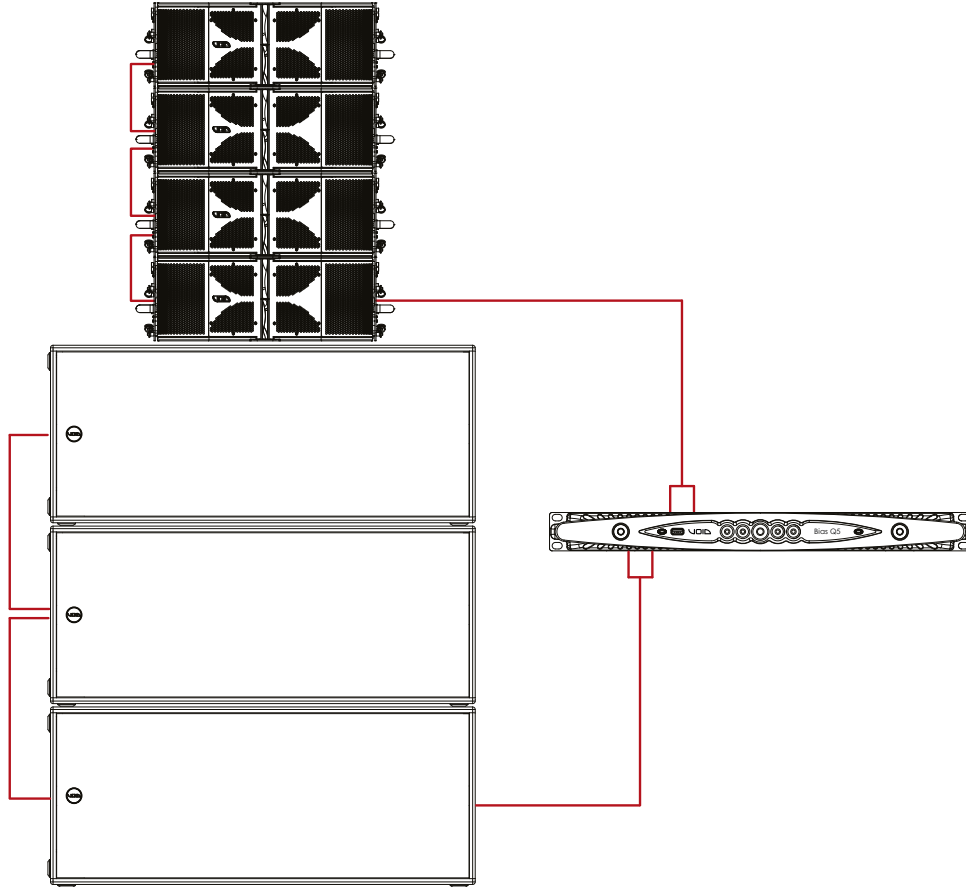

Figure 7.1: 3 x Arcline 218 and 4 x Arcline 8

A standard configuration for ground stacking is three Arcline 218 with four Arcline 8. This gives a loading of 2.66Ω on channel 1 and 2 for the Arcline 218 and 4Ω on channel 3 and 4 for the Arcline 8. Loading the amplifiers asymmetrically like this makes use of the amplifiers power sharing capabilities.

7 Typical Configurations

7.2 Flying Arcline 8

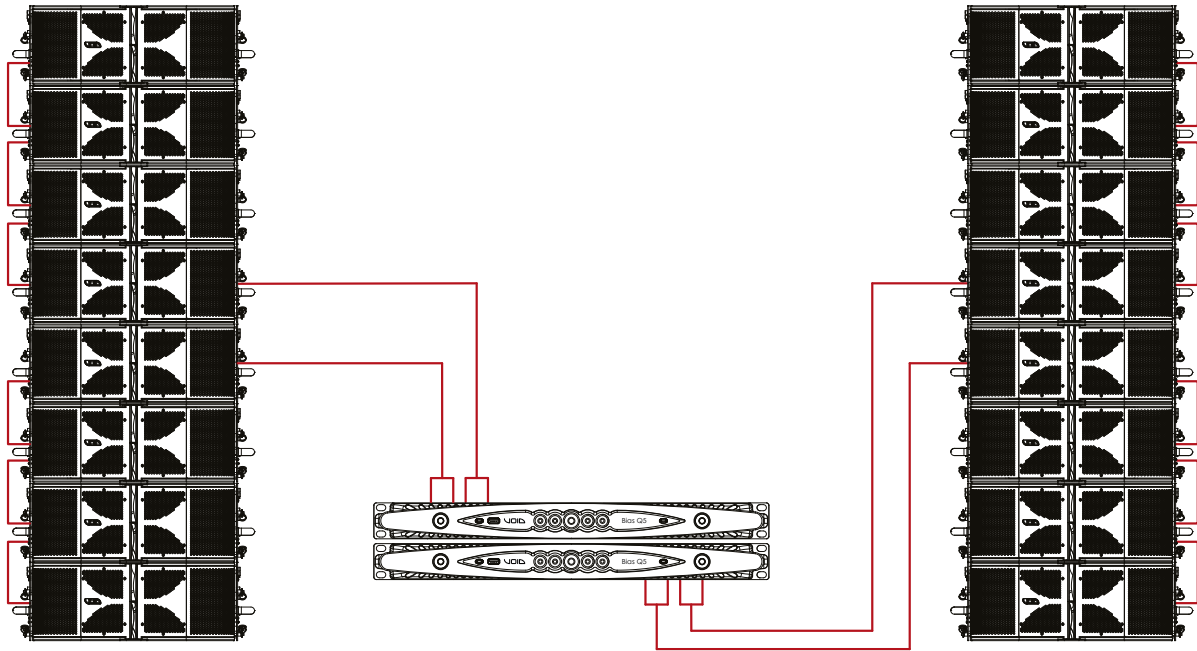

Figure 7.2: 16 Arcline 8

Flying eight Arcline 8 per side for stereo sound with four cabinets per every two amplifier channels keeping the impedance at 4 Ω . Use one amplifier per side.

7.3 Flying Arcline 8 with Arcline 212

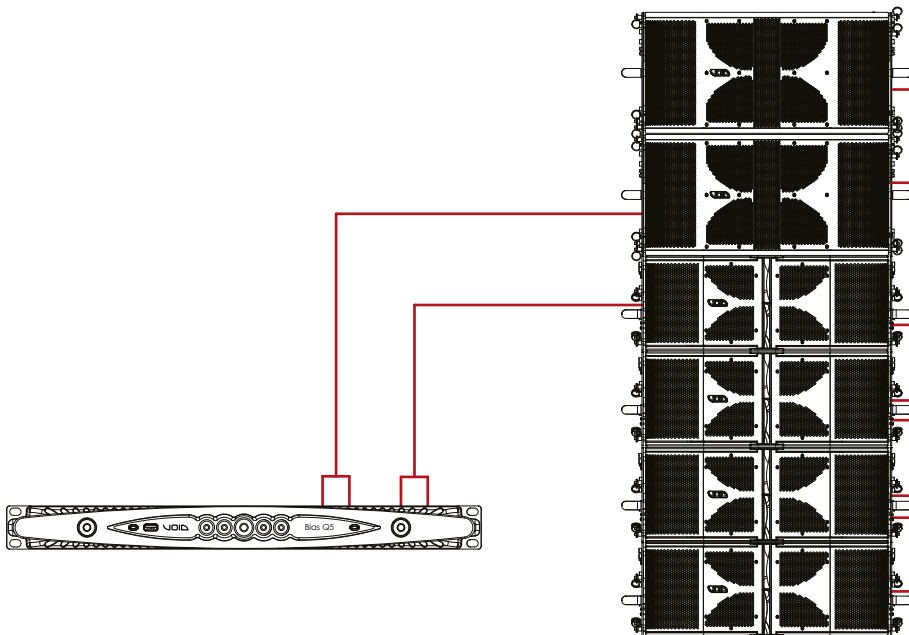

Figure 7.3: Arcline 8 with Arcline 212

Arcline 8 and Arcline 212 should be configured in a 2:1 ratio. Two Arcline 212 and four Arcline 8 keeps the impedance to 4 Ω .

8 Service

Void Arcline loudspeakers should only be serviced by a fully-trained technician.



No user serviceable parts inside. Refer servicing to your dealer.

8.1 Return authorisation

Before returning your faulty product for repair, please remember to get an R.A.N. (Return Authorisation Number) from the Void dealer who supplied the system to you. Your dealer will handle the necessary paperwork and repair. Failure to go through this return authorisation procedure could delay the repair of your product.

Note that your dealer will need to see a copy of your sales receipt as proof of purchase so please have this to hand when applying for return authorisation.

8.2 Shipping and packing considerations

- When sending a Void Arcline loudspeaker to an authorised service centre, please write a detailed description of the fault and list any other equipment used in conjunction with the faulty product.
- Accessories will not be required. Do not send the instruction manual, cables or any other hardware unless your dealer asks you to.
- Pack your unit in the original factory packaging if possible. Include a note of the fault description with the product. Do not send it separately.
- Ensure safe transportation of your unit to the authorised service centre.

9 Appendix A - Accessories

Arcline 8 fly frame / ground stack frame (product number IT3197)

- Frame to fly Arcline 8 - or to stack on flat surface when inverted



Arcline 8 flight case (product number IT1198)

- Flight case for Arcline 8
- Clamshell design
- Holds four Arcline 8



Arcline 8 fly frame flight case (product number IT1197)

- Flight case for Arcline 8 Fly Frame
- Holds two Fly Frames
- Central compartment for hardware storage



Arcline 212 flight case (product number IT2922)

- Flight case for Arcline 212
- Holds two Arcline 212



Arcline RAL extension (product number IT1832)

- Stacking spacer for ground stack of Arcline 8
- Adds 10° tilt



9 Appendix B - Connectors and Cabling

Bias Q5 amplifier input cable connectors

Analog input XLR-M pinout

| | |
|-------|--------|
| Pin 1 | GND |
| Pin 2 | HOT ⊕ |
| Pin 3 | COLD ⊖ |

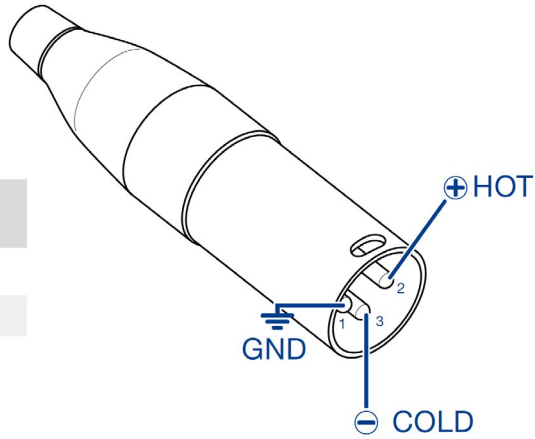

Analog input TRS Jack pinout

| | |
|--------|--------|
| Tip | HOT ⊕ |
| Ring | COLD ⊖ |
| Sleeve | GND |

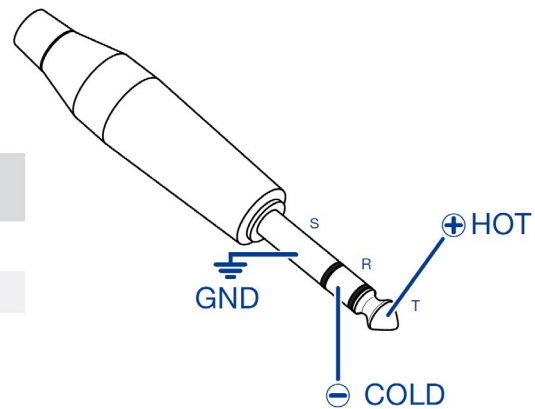

XLR or TRS jack analogue input cable connectors

AES 3 input XLR-M pinout

| | |
|-------|--------|
| Pin 1 | GND |
| Pin 2 | SIGNAL |
| Pin 3 | SIGNAL |

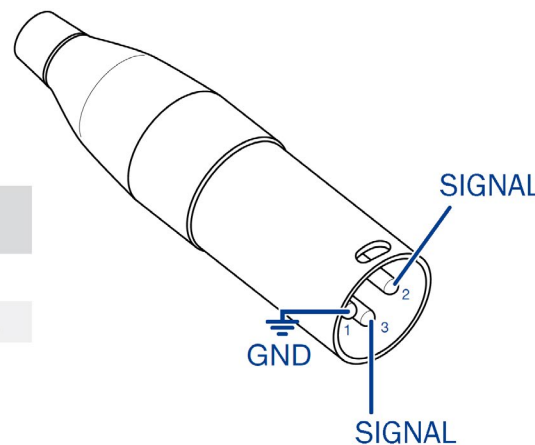

XLR AES 32-channel digital audio cable connector
(Use V9 IN2 socket)



Note

For AES3 2-channel digital audio signals via a 110 Ω twisted pair cable, XLR pins 2 & 3 polarity is unimportant.

9 Appendix B - Connectors and Cabling

Bias Q5 DSP amplifier 1000BASE-T S/UTP Ethernet cable connectors

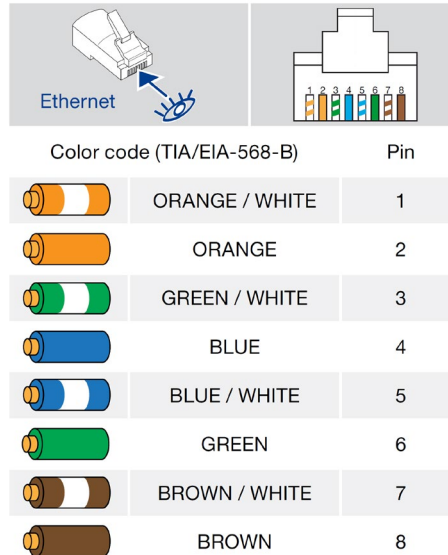

1000BASE-T (4-pair) S/UTP* ethernet cable pinouts suitable for data + AES3 (AESOP) applications. (*Note S/UTP – not U/UTP)

Braided-shield 1000BASE-T (4-pair) S/UTP Cat-5e ethernet cables(overall braided-Shield protecting Unshielded Twisted Pairs to ISO/IEC 11801:200) can normally be used to convey AESOP (AES3 & Ethernet Simple Open Protocol) digital audio plus control data for distances up to 100 m.

Lower cost U/UTP Cat-5e cables (Unshielded Twisted Pair with no overall shield – as defined by ISO/IEC 11801:200) may be used in low-interference environments – but you must avoid running cables near mains, lighting or video screen drive cables.



Adherence to the colour-coding (TIA/EIA-568-B standard illustrated) is very important as the cable comprises four carefully-designated twisted pairs (1 & 2 - orange, 3 & 6 - green, 4 & 5 - blue, 7 & 8 - brown). Ignoring this pairing will defeat the cable's common mode rejection and will degrade performance.

9 Appendix C - Architectural Specifications

Arcline 8 architectural specifications

The loudspeaker shall be a two way active, three-way line array module system consisting of two high power 8" (203.2 mm) direct radiating reflex loaded low frequency (LF) transducer, two high power 8" (203.2 mm) direct radiating reflex loaded mid frequency (MF) transducer and two 1.4" (35.6 mm) exit high frequency (HF) compression transducers on a proprietary planar wave tube mounted in a birch plywood enclosure.

The low and mid frequency transducers shall be constructed on a cast aluminium frame, with a treated paper cone, 50.8 mm (2") voice coil, wound with copper wires on a high quality Kapton voice coil former, for high power handling and long-term reliability. The high frequency transducer shall project its sound through an elliptic horn with a 150 mm (6") baffle diameter to achieve pattern control and low distortion.

Performance specifications for a typical production unit shall be as follows: the usable on-axis bandwidth shall be 110 Hz to 20 kHz (± 3 dB) for a single enclosure and 90 Hz – 20 kHz for three enclosures; shall average 110° directivity pattern on the horizontal axis and 12° on the vertical one (-6 dB down from on-axis level) from 1 kHz to 12 kHz; maximum SPL of 145 dB peak measured at 1 m using IEC268-5 pink noise bursts. Power handling shall be 500 W AES at a rated impedance of $2 \times 16 \Omega$; crossover point at 1.2 kHz using a 2nd order filter (24 dB per octave). The wiring connection shall be via two Neutrik speakON™. One for input and one for loop-out to another speaker, to allow for pre-wiring of the connector before installation.

The enclosure shall be constructed from 15 mm multi-laminate birch plywood finished in a textured polyurea and shall contain fixture points for a pressed weather-resistant steel powder coated grille with foam filter. The integral rigging system shall allow for inter cabinet angles of 1,2,3,4,5,6,7,8,9 and 10 degrees with stowage positions for transport. The cabinet shall have two handles (one per side) for efficient manual handling. External dimensions of (H) 285 mm x (W) 881 mm x (D) 470 mm (11.2" x 34.7" x 18.5"). Weight shall be 39 kg (86 lbs).

The loudspeaker system shall be a Void Acoustics Arcline 8.

9 Appendix C - Architectural Specifications

Arcline 212 architectural specifications

The loudspeaker shall be a compact sub bass system consisting of two high power 12" (304.8 mm) direct radiating reflex loaded low frequency (LF) transducers mounted in a rectangular enclosure.

The low frequency transducers shall be constructed on a cast aluminium frame, with a treated paper cone, dual 50.8 mm (2") voice coil, wound with copper wires on a high-quality voice coil former for high power handling and long-term reliability.

Performance specifications for a typical production unit shall be as follows: the usable bandwidth shall be 50 Hz to 200 Hz (± 3 dB) and have a maximum on axis SPL of 138 dB peak (132 dB continuous) measured at 1 m using IEC265-5 pink noise. Power handling shall be 2 x 900 W AES at a rated impedance of 2 x 8 Ω and a pressure sensitivity of 99 dB measured at 1W/1m. The system shall be powered by its own dedicated power amplification module with DSP management, with the wiring connection via two Neutrik speakON™; one for input and one for loop-out to another speaker.

The enclosure shall be constructed from a 15 mm multi-laminate birch plywood, finished in a textured polyurethane and shall contain fixture points for a pressed weather-resistant, powder coated steel grille to protect the low frequency transducer. The integral rigging system shall be stainless steel with two handles (one per side) for efficient manual handling. External dimensions of (H) 367 mm x (W) 877.5 mm x (D) 470 mm (14.4" x 34.5" x 18.5"). Weight shall be 42 kg (92.6 lbs).

The loudspeaker system shall be a Void Acoustics Arcline 212.

NORTH AMERICA

Void Acoustics North America

Call: +1 630 686 6616

Email: hello@voidacoustics.com

HEAD OFFICE

Void Acoustics Research Ltd,
Unit 15, Dawkins Road Industrial Estate,
Poole, Dorset,
BH15 4JY
United Kingdom

Call: +44(0) 1202 666006

Email: hello@voidacoustics.com



Hear. Feel. Connect.

voidacoustics.com