

**VOID**

Hear. Feel. Connect.

[voidacoustics.com](http://voidacoustics.com)



# Cyclone 8

Sculpted sound, compact styling

USER GUIDE V2.2

©2026 Void Acoustics Research Ltd.

This user guide is subject to change without notice.  
For the latest online version, visit: [www.voidacoustics.com](http://www.voidacoustics.com)

Void Acoustics and the Void logo are registered trademarks of Void Acoustics Research Ltd. in the United Kingdom, USA and other countries; all other Void trademarks are the property of Void Acoustics Research Ltd.

# Contents

<b>1</b>	<b>Safety and Regulations</b>	<b>4</b>
1.1	Important Safety Instructions	4
1.2	Limitations	4
1.3	EC Declaration of Conformity	4
1.4	UKCA Conformity	4
1.5	Warranty Statement	4
1.6	WEEE Directive	4
<b>2</b>	<b>Unpacking and Checking</b>	<b>5</b>
<b>3</b>	<b>About</b>	<b>6</b>
3.1	Welcome	6
3.2	Cyclone 8 Overview	6
3.3	Key Features	6
3.4	Cyclone 8 Specifications	7
3.5	Cyclone 8 Dimensions	7
<b>4</b>	<b>Cable and Wiring</b>	<b>8</b>
4.1	Electrical Safety	8
4.2	Cable Considerations for Fixed Installations	8
4.3	Phoenix Connector	8
4.4	Cyclone Glanded Connector Wiring	9
4.5	Cyclone 8 Wiring Diagram	11
4.6	Bias D1/Q1/Q2 Phoenix Wiring	11
4.7	Bias Q3/Q5 speakON™ Wiring	12
<b>5</b>	<b>Mounting</b>	<b>13</b>
5.1	Installation Safety	13
5.2	Wall Mounting	14
5.3	Ceiling Mounting	16
<b>6</b>	<b>Service</b>	<b>18</b>
6.1	Return Authorisation	18
6.2	Shipping and Packing Considerations	18
<b>7</b>	<b>Appendix</b>	<b>19</b>
7.1	Application Note: Loudspeakers in Corrosive Environments	19
7.2	Architectural Specifications	20
7.3	Changelog	20

# 1 Safety and Regulations

## 1.1 Important safety instructions



The lightning flash with an arrowhead symbol within an equilateral triangle is intended to alert the user to the presence of uninsulated "dangerous voltage" within the product's enclosure that may be of sufficient magnitude to constitute a risk of electric shock to persons.



The exclamation point within an equilateral triangle is intended to alert the user of the presence of important operating and maintenance (servicing) instructions in the literature accompanying the appliance.

## Safety instructions - read this first

1. Read these instructions.
2. Keep these instructions.
3. Heed all warnings.
4. Follow all instructions.
5. Do not use this apparatus near water.
6. Clean only with a dry cloth.
7. Do not block any ventilation openings. Install in accordance with the manufacturer's instructions.
8. Do not install near any heat source such as radiators, heat registers, stoves, or other such apparatus that produce heat.
9. Do not defeat the safety purpose of the grounding-type plug. A grounding type plug has two blades and a third grounding prong. The third prong is provided for your safety. If the provided plug does not fit into your outlet, consult an electrician for replacement of the obsolete outlet.
10. Protect power cords from being walked on or pinched particularly at plugs, convenience receptacles, and the point where they exit the apparatus.
11. Only use attachments and accessories specified by Void Acoustics.
12. Only use with the cart, stand, tripod, bracket, or table specified by the manufacturer, or sold with the apparatus. When a cart is used, use caution when moving the cart/apparatus combination to avoid injury from tip-over.
13. Unplug the apparatus during lightning storms or when unused for long periods of time.
14. Refer all servicing to qualified service personnel. Servicing is required when the apparatus has been damaged in any way, such as when the power-supply cord or plug is damaged, liquid has been spilled or objects have fallen into the apparatus, the apparatus has been exposed to rain or moisture, does not operate normally, or has been dropped.
15. Since the mains power supply cord attachment plug is used to disconnect the device, the plug should always be easily accessible.
16. Void loudspeakers can produce sound levels capable of causing permanent hearing damage from prolonged exposure. The higher the sound level, the less exposure needed to cause such damage. Avoid prolonged exposure to the high sound levels from the loudspeaker.

## 1.2 Limitations

This guide is provided to help familiarise the user with the loudspeaker system and its accessories. It is not intended to provide comprehensive electrical, fire, mechanical and noise training and is not a substitute for industry-approved training. Nor does this guide absolve the user of their obligation to comply with all relevant safety legislation and codes of practice. While every care has been taken in creating this guide, safety is user-dependent and Void Acoustics Research Ltd cannot guarantee complete safety whenever the system is rigged and operated.

## 1.3 EC declaration of conformity

For EC Declaration of Conformity please go to:

[www.voidacoustics.com/eu-declaration-loudspeakers](http://www.voidacoustics.com/eu-declaration-loudspeakers)

## 1.4 UKCA marking

For details of the UKCA marking go to:

[www.voidacoustics.com/uk-declaration-loudspeakers](http://www.voidacoustics.com/uk-declaration-loudspeakers)

## 1.5 Warranty statement

For warranty statement go to:

<https://voidacoustics.com/terms-conditions/>

## 1.6 WEEE directive

If the time arises to throw away your product, please recycle all the components possible.



This symbol indicates that when the end-user wishes to discard this product, it must be sent to separate collection facilities for recovery and recycling. By separating this product from other household-type waste, the volume of waste sent to incinerators or land-fills will be reduced and natural resources will thus be conserved.

The Waste Electrical and Electronic Equipment Directive (WEEE Directive) aims to minimise the impact of electrical and electronic goods on the environment. Void Acoustics Research Ltd complies with the Directive 2002/96/EC and 2003/108/EC of the European Parliament on waste electrical and electronic equipment (WEEE) in order to reduce the amount of WEEE that is being disposed of in land-fill sites. All of our products are marked with the WEEE symbol; this indicates that this product must NOT be disposed of with other waste. Instead it is the user's responsibility to dispose of their waste electrical and electronic equipment by handing it over to an approved reprocessor, or by returning it to Void Acoustics Research Ltd for reprocessing. For more information about where you can send your waste equipment for recycling, please contact Void Acoustics Research Ltd or one of your local distributors.



## 2 Unpacking and Checking

All Void Acoustics products are carefully manufactured and thoroughly tested before being despatched. Your dealer will ensure that your Void products are in pristine condition before being forwarded to you but mistakes and accidents can happen.

Before signing for your delivery:

- Inspect your shipment for any signs of contamination, abuse or transit damage as soon as you receive it
- Check your Void Acoustics delivery fully against your order
- If your shipment is incomplete or any of its contents are found to be damaged; inform the shipping company and inform your dealer.

When you are removing your Cyclone 8 loudspeaker from its original packaging:

- Cyclone 8 loudspeakers come double boxed are stapled shut; take care when unboxing and removing the staples to avoid injury or damage to the loudspeaker
- If you need to place the loudspeaker on a flat surface ensure you use a lint free product to protect the finish
- When you have removed the Cyclone 8 loudspeaker from the packaging inspect it to ensure there is no damage and keep all original packaging in case it needs to be returned for any reason.

See section 1.5 for warranty conditions and see section 6 if your product needs service.

# 3 About

## 3.1 Welcome

Many thanks for purchasing this Void Acoustics Cyclone Series loudspeaker. We truly appreciate your support. At Void, we design, manufacture and distribute advanced professional audio systems for the installed and live sound market sectors. Like all Void products, our highly skilled and experienced engineers have successfully combined pioneering technologies with ground-breaking design aesthetics, to bring you superior sound quality and visual innovation. In buying this product, you are now part of the Void family and we hope using it brings you years of satisfaction. This guide will help you both use this product safely and ensure it performs to its full capability.

## 3.2 Cyclone 8 overview

Positioning itself as the ideal mid-point between the Cyclone 55 and Cyclone 10 models, the Cyclone 8 offers an installation-friendly package with an IP-55 rating for both indoor and outdoor use. High-quality sound is guaranteed across diverse applications, ranging from stand-alone use in beach bars, lounges, and hotels to providing area fill alongside larger club systems.

State-of-the-art porting ensures minimal turbulent noise and maximum low-frequency performance. Furthermore, the low-frequency transducer and one-inch coaxially mounted high-frequency compression driver deliver superior efficiency within a compact, stylish form. Flexible mounting solutions facilitate quick, secure installation with a wide range of adjustment.

## 3.3 Key features

- Passive 8 inch coaxial surface mount loudspeaker
- Weather-resistant input glands with Phoenix connector and link-through functionality
- Low-resonance fibreglass composite construction
- Conical 90° dispersion pattern
- Full range reflex-loaded design
- Stainless steel grille and fasteners
- T80-style fixing points for compatibility with a wide range of mounting options
- Weather-protected with an IP-55 rating
- UV resilient finish
- Available as standard in red with a black grille, black with a black grille, and white with a white grille. Custom RAL and KROME finishes are available upon request

# 3 About

## 3.4 Cyclone 8 specifications

Frequency Response <sup>1</sup>	75 Hz - 20 kHz
Maximum Output <sup>2</sup>	115 dB cont, 121 dB peak
Nominal Dispersion	90°H x 90°V
Sensitivity <sup>3</sup>	94 dB 1W/1m
Driver Configuration	1 x 8" LF, 1 x 1" HF coaxial compression driver
Power Handling	200 W AES
Nominal Impedance	8 $\Omega$
Suggested Minimum Amplifier	Bias Q1+
Weight	14 kg (31 lbs)
IP Rating	IP-55
Connections	Phoenix connector with link out
Enclosure	Fibreglass composite
Finish	Smooth cellulose
Mounting	Type 80 Plate
Height	281 mm (11")
Width	450 mm (17.7")
Depth	317 mm (12.5")

1 -10 dB IEC 60268-5 2 Calculated 3 Measured in half space

## 3.5 Cyclone 8 dimensions

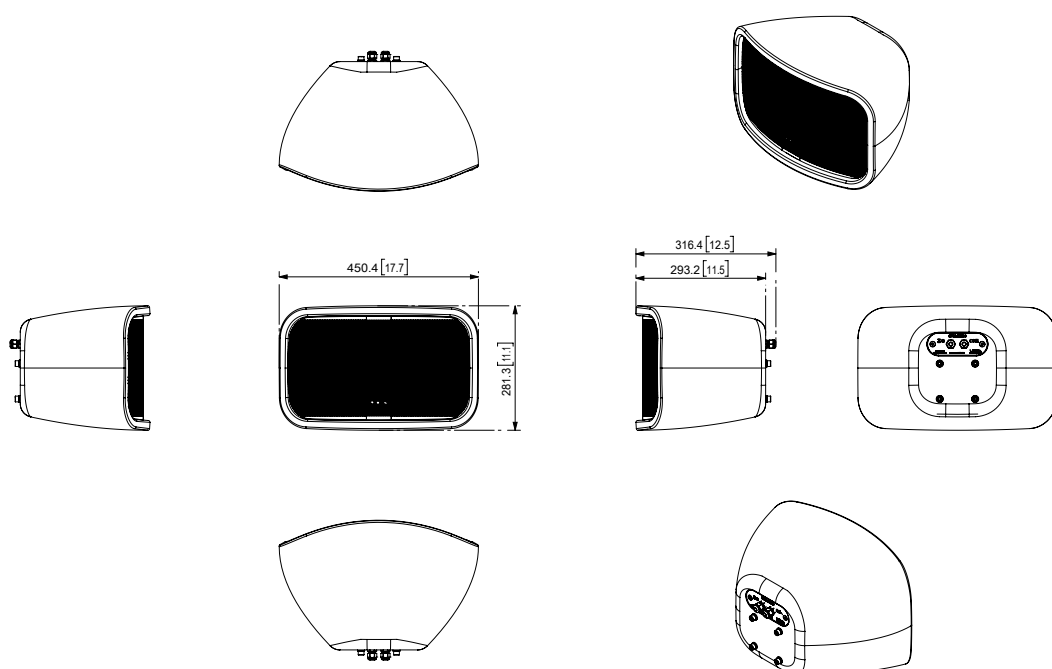

Figure 3.1: Dimensions

# 4 Cable and Wiring

## 4.1 Electrical safety



To avoid electrical hazards please note the following:

- Do not access the inside of any electrical equipment. Refer servicing to Void-approved service agents.

## 4.2 Cable considerations for fixed installations

We recommend specifying installation-grade Low Smoke Zero Halogen (LSZH) cables for permanent installations. The cables should use Oxygen Free Copper (OFC) of grade C11000 or above. Cables for permanent installations should be compliant with the following standards:

- IEC 60332.1 Fire retardancy of a single cable
- IEC 60332.3C Fire retardancy of bunched cables
- IEC 60754.1 Amount of Halogen Gas Emissions
- IEC 60754.2 Degree of acidity of released gases
- IEC 61034.2 Measurement of smoke density.

We suggest using the following maximum copper cable lengths to keep level losses below 0.6 dB.

Metric mm <sup>2</sup>	Imperial AWG	16 $\Omega$ load	8 $\Omega$ load	4 $\Omega$ load	2 $\Omega$ load
2.50 mm <sup>2</sup>	13 AWG	72 m	36 m	18 m	9 m
4.00 mm <sup>2</sup>	11 AWG	120 m	60 m	30 m	15 m

## 4.3 Phoenix connector

Figure 4.1 shows the rear panel of a Cyclone Series loudspeaker with the polarity of the Phoenix connector labelled. When viewed from the rear the connectors are negative, positive, negative, positive, from left to right.

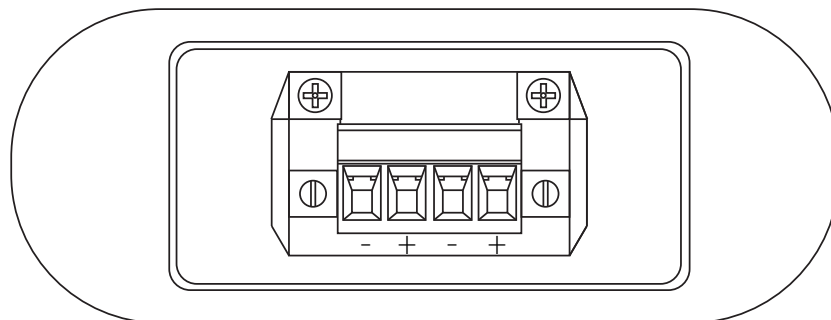

Figure 4.1: Phoenix connector diagram

# 4 Cable and Wiring

## 4.4 Cyclone glanded connector wiring

- Remove both M6 bolts from the rear of the connector plate

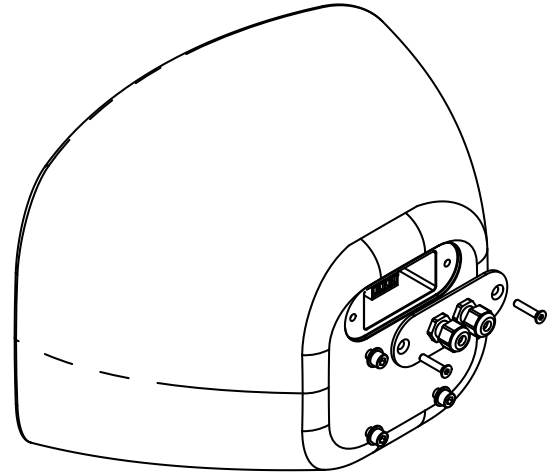

Figure 4.2: Connector plate removal

- Undo the glanded connectors from the rear of the connector plate.

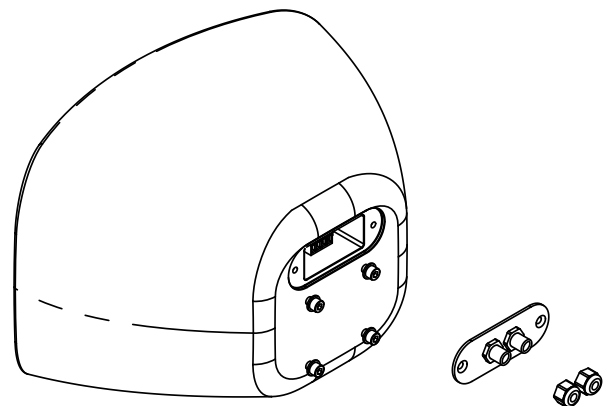

Figure 4.3: Glanded connector removal

- Insert the cable through the glanded connectors and tighten.

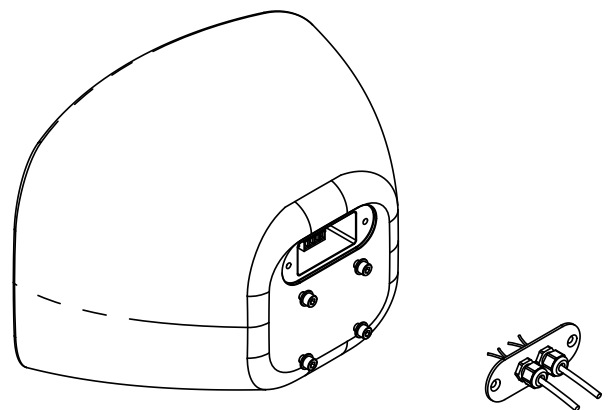

Figure 4.4: Cable connection

# 4 Cable and Wiring

- Attach the cable to the phoenix connector.

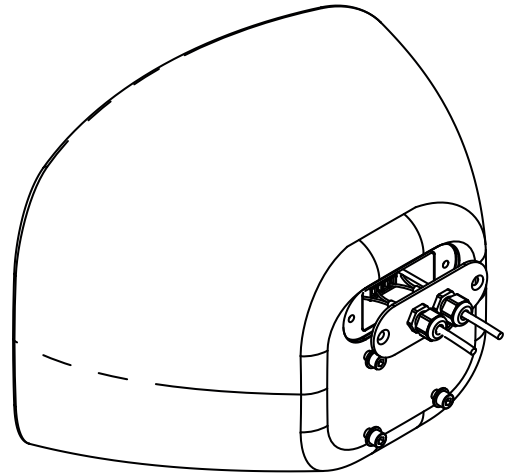

Figure 4.5: Phoenix attachment

- Position the connector plate and insert the two M6 bolts.

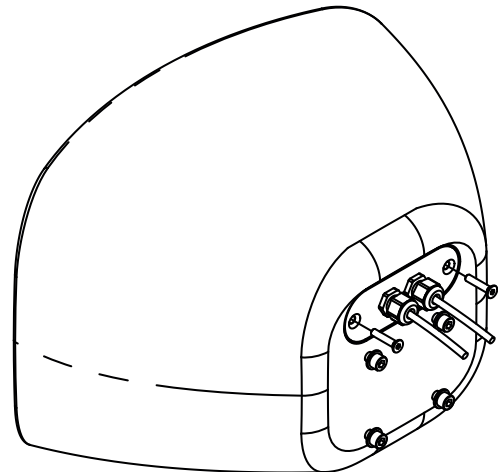

Figure 4.6: Connector plate connection

# 4 Cable and Wiring

## 4.5 Cyclone 8 wiring diagram

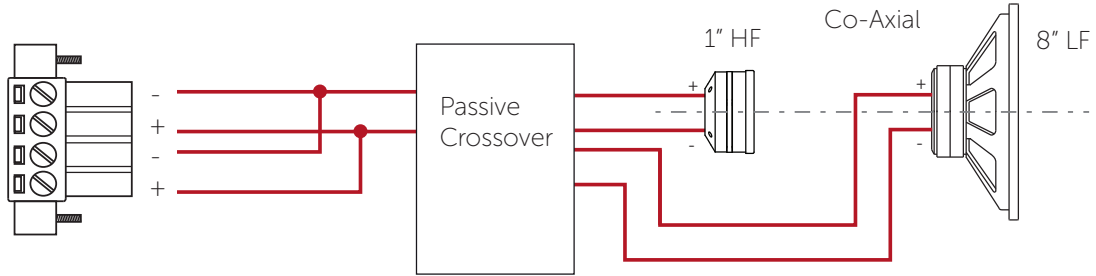

Figure 4.7: Wiring diagram

	Phoenix pins 1-/1+	Phoenix pins 2-/2+
In	HF (1") and LF (8")	Link/out

## 4.6 Bias D1/Q1/Q2 Phoenix wiring

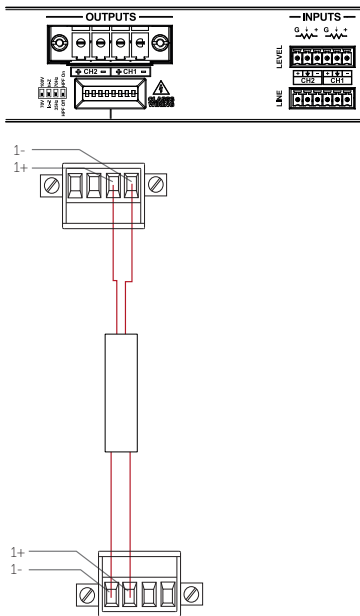

Figure 4.8: Bias D1 output connection

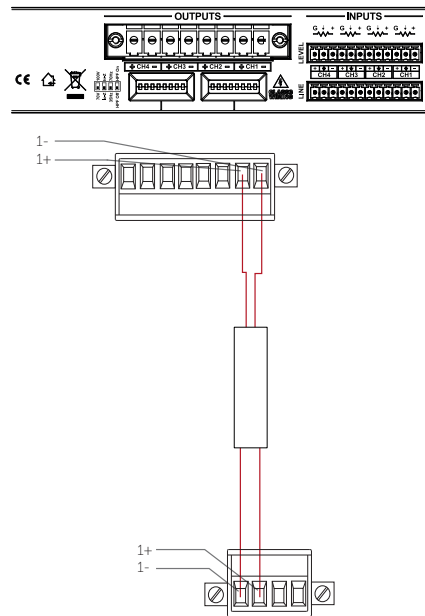

Figure 4.9: Bias Q1/Q2 output connection

Bias D1/Q1/Q2	Out 1
Output	LF (8") and HF (1")
Max parallel units	4 (2 $\Omega$ load to amplifier)

# 4 Cable and Wiring

## 4.7 Bias Q3/Q5 speakON™ wiring

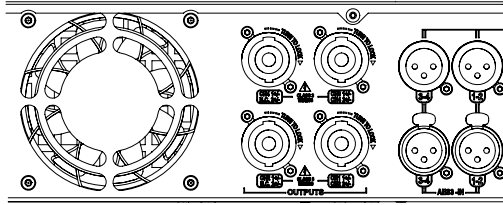

Figure 4.10: Bias Q3

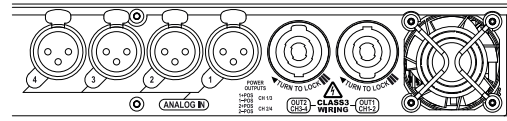

Figure 4.11: Bias Q5

Bias Q3/Q5	Out 1
Output	LF (8") and HF (1")
Max quantity per channel	4 (2 $\Omega$ load to amplifier)

# 5 Mounting

## 5.1 Installation safety

To avoid mechanical hazards, please note the following:



- Safety regulations vary in different regions. Full compliance with those regulations must be your priority
- Installations must only be undertaken by fully qualified and experienced engineers/technicians who understand local regulations
- This may include consulting a structural engineer before installation of wall brackets
- Remember that all personnel have a duty of care to themselves, to their assistants, to the venue staff and to the public
- Before lifting any part of the system above head height, check the whole rig for loose tools or other items that may fall and cause injury
- Do not use a telephone (even if hands-free) whilst installing. Always concentrate fully on the installation operation
- Do not install equipment that is worn, damaged, corroded, mishandled or overstressed in any way
- Use only Void-approved mounting equipment and accessories
- Secondary safeties should be provided in all instances where cabinets are flying or fixing overhead and should conform to local regulations

# 5.2 Wall Mounting

Parts required:

T80XL - Wall Bracket	White - IT1115
	Black - IT1114

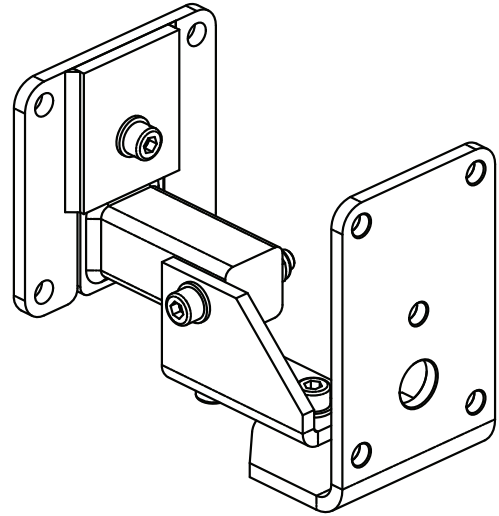

Figure 5.1: T80XL wall mount bracket

Step 1:  
Remove all four M8 bolts from the rear of the loudspeaker.

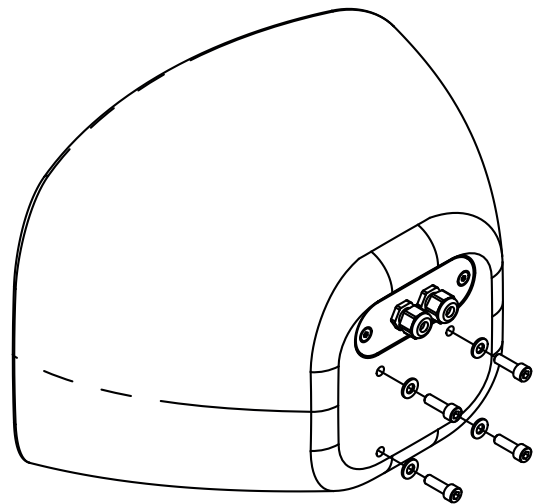

Figure 5.2: Cyclone 8 bolt removal

Step 2:  
Remove the front of the bracket from the main bracket assembly. Attach the rear of the bracket assembly to the wall making sure all 4 bolts are fitted.



Take care when mounting the bracket to the wall, making sure to use the correct fixing and that the wall can take the load, for example do not attach the bracket to a stud wall.

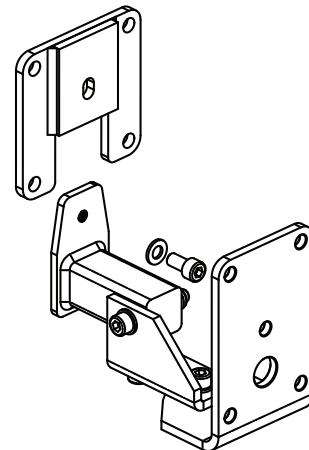

Figure 5.3: Deconstructing the bracket assembly

# 5.2 Wall Mounting

Step 3:  
Attach the front of the bracket assembly to the rear of the loudspeaker using all four M8 bolts.

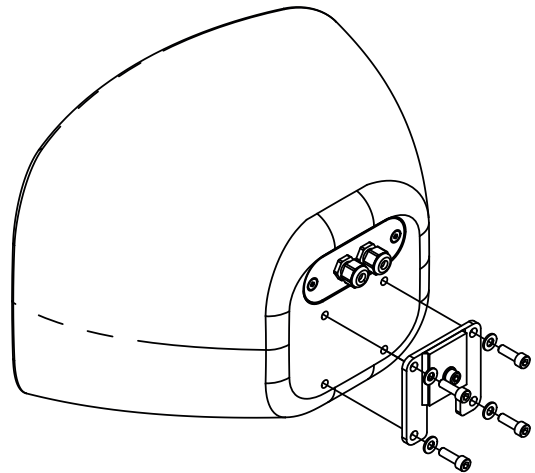

Figure 5.4: Attaching bracket to loudspeaker

Step 4:  
Lower the speaker assembly on to the rear of the bracket assembly and fix the bolt into the rear of assembly.

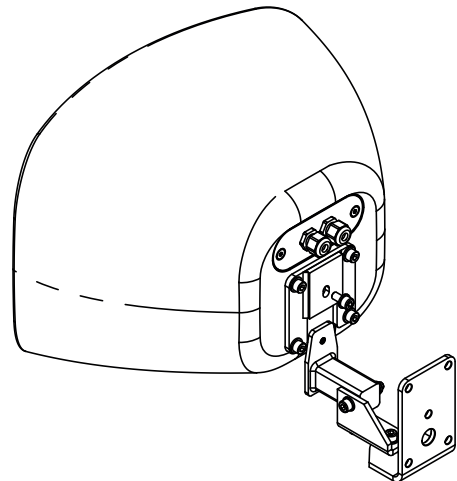

Figure 5.5: Attaching loudspeaker to bracket

Step 5:  
Adjust the bracket in the horizontal axis by loosening the bolt at the rear of the assembly (figure 5.6a) and in the vertical axis by adjusting the bolt on the base of the assembly (figure 5.6b).

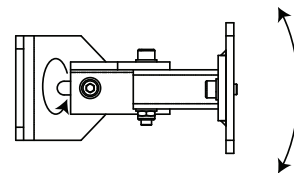

Figure 5.6a: Bracket adjustment

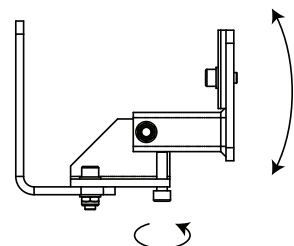

Figure 5.6b: Bracket adjustment

# 5.3 Ceiling Mounting

Parts required:

T80 - Ceiling Bracket	White - IT1106
	Black - IT1105

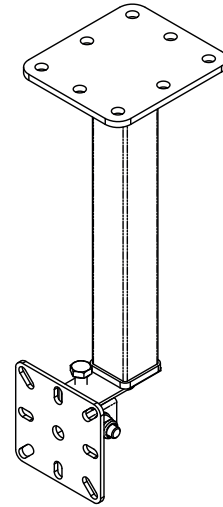

Figure 5.7: Venu Series Ceiling Mount Bracket

Step 1:  
Remove all four M8 bolts from the rear of the loudspeaker.

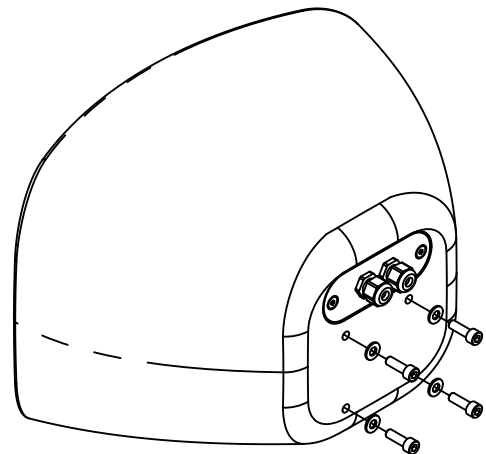

Figure 5.8: Cyclone bolt removal

Step 2:  
Remove the M10 nut and washer from the base of the T80 ceiling bracket and remove the connector plate. At this stage fix the ceiling bracket in its operational location



Take care when mounting the bracket to the ceiling, making sure to use the correct fixing and that the ceiling can take the load.

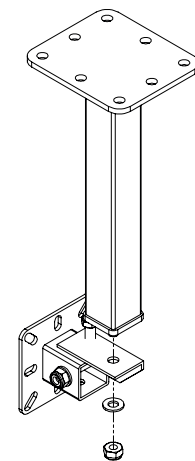

Figure 5.9: Deconstruction the bracket

## 5.3 Ceiling Mounting

### Step 3:

Remove all four M8 bolts and washers from the rear of the cabinet. Fix the connector plate to the cabinet with all four M8 bolts.

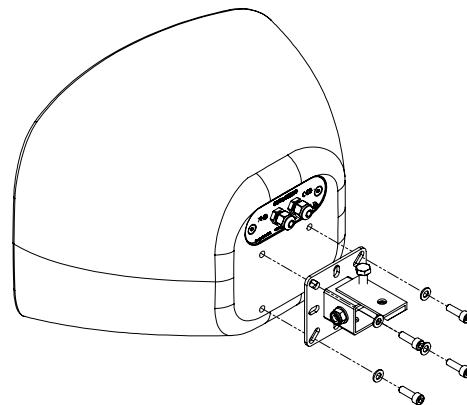

Figure 5.10: Plate attachment

### Step 4:

Fix the connector plate to the bracket using the M10 nut and washer.

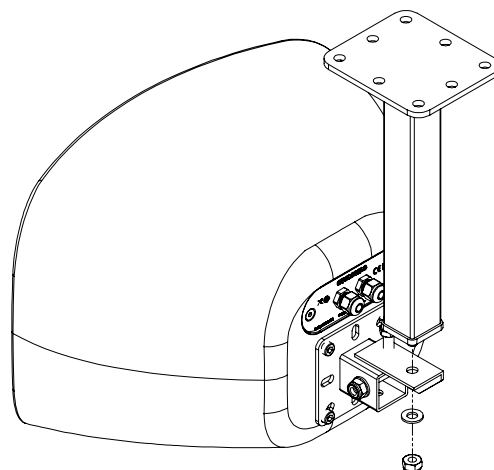

Figure 5.11: Bracket fixing

### Step 6:

Use the bolt shown to adjust the vertical orientation.

Max horizontal rotation:  $360^\circ$

Max vertical rotation:  $\pm 12^\circ$

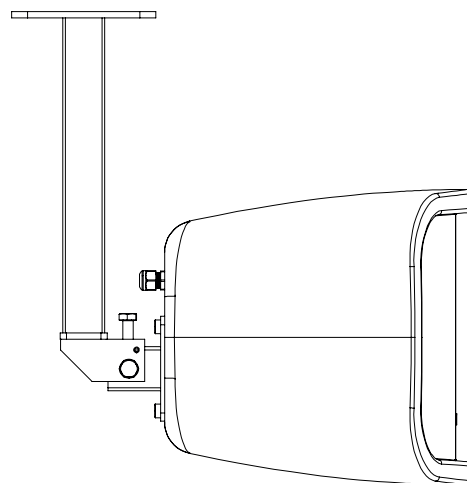

Figure 5.12: Rotation

# 6 Service

Void Cyclone Series loudspeakers should only be serviced by a fully-trained technician.



No user serviceable parts inside. Refer servicing to your dealer.

## 6.1 Return authorisation

Before returning your faulty product for repair, please remember to get an R.A.N. (Return Authorisation Number) from the Void dealer who supplied the system to you. Your dealer will handle the necessary paperwork and repair. Failure to go through this return authorisation procedure could delay the repair of your product.

Note that your dealer will need to see a copy of your sales receipt as proof of purchase so please have this to hand when applying for return authorisation.

## 6.2 Shipping and packing considerations

- When sending a Cyclone Series loudspeaker to an authorised service centre, please write a detailed description of the fault and list any other equipment used in conjunction with the faulty product.
- Accessories will not be required. Do not send the instruction manual, cables or any other hardware unless your dealer asks you to.
- Pack your unit in the original factory packaging if possible. Include a note of the fault description with the product. Do not send it separately.
- Ensure safe transportation of your unit to the authorised service centre.

# 7 Appendix

## 7.1 Application Note: Loudspeakers in Corrosive Environments

Void Acoustics' weather protected and IP rated products are suitable for outdoor use, however installations in highly corrosive environments, such as high salinity or in the presence of corrosive chemicals such as chlorine, require additional care and maintenance. The following guide will help to prevent corrosion and prolong both the product aesthetics and sonic performance. It is recommended that this process is implemented weekly.

Step 1: Remove the grill as applicable (please refer to Section 8 for instructions) and wash with deionised water, ensuring all build-up of contamination is removed completely from the grille and the foam (where fitted). Allow the foam to dry completely before reinstalling, protecting the loudspeaker accordingly in the interim.

Step 2: Using a clean microfibre cloth and deionised water, use circular motions working from the top of the product down to remove contamination. Dry the product with a clean, dry microfibre cloth.

Step 3: Use a soft bristled brush and deionised water to clean the bracketry, ensuring all contamination is removed completely.

# 7 Appendix

## 7.2 Cyclone 8 architectural specification

The loudspeaker shall be a passive two-way system consisting of one high power 8" (203.2 mm) direct radiating reflex loaded low frequency (LF) transducer and a 1" (25 mm) diameter co-axially-mounted high frequency (HF) compression transducer mounted in a fibreglass, smooth cellulose enclosure.

The low frequency transducer shall be constructed on a cast aluminium frame, with a treated paper cone, 50.8 mm (2") voice coil, wound with copper wires on a high quality voice coil former, for high power handling and long-term reliability. The high frequency transducer shall be bolted through the rear of the magnet structure belonging to the LF transducer to form a co-axial drive unit. The sound will project through a machined waveguide that exits in the centre of the low frequency transducer to use the 203.2 mm (8") baffle diameter to achieve pattern control and low distortion.

Performance specifications for typical production unit shall be as follows: the usable on-axis bandwidth shall be 75 Hz to 20 kHz (-10 dB IEC 60268-5) and shall average 90° directivity pattern for both horizontal and vertical axis (-6 dB down from on-axis level) from 1 kHz to 10 kHz; maximum SPL of 115 dB continuous, 121 dB peak measured at 1 m using IEC268-5 pink noise. Power handling shall be 200 W AES at a rated impedance of 8  $\Omega$ ; crossover point at 2 kHz using a 2nd order filter (12 dB per octave).

The wiring connection shall be via a single, removable, lockable wiring connector with four screw-down terminals (one pair for input and one pair for loop-out to another loudspeaker) to provide secure wiring and to allow for pre-wiring of the connector before the installation. This connector should then screw lock to the enclosure to ensure secure attachment. The enclosure shall be of a moulded fibreglass reinforced plastic construction with a smooth cellulose finish and shall include integral threaded inserts for the fitment of wall and ceiling mounting hardware of any RAL colour with external dimensions of (H) 281 mm x (W) 450 mm x (D) 293 mm (11" x 17.7" x 11.5"). Weight shall be 14 kg (31 lbs).

The loudspeaker shall be the Void Acoustics Cyclone 8.

## 7.3 Changelog

Document Version	Notes	Valid for S.N
UG10582-2.2	Updated specs to IEC 60268-5	C88XXXX - Current

## NORTH AMERICA

Void Acoustics North America

**Call:** +1 (630) 686 6616

**Email:** [sales.usa@voidacoustics.com](mailto:sales.usa@voidacoustics.com)

## HEAD OFFICE

Void Acoustics Research Ltd

Unit L, The Fulcrum

Vantage Way

Poole

BH12 4NU

United Kingdom

**Call:** +44(0) 1202 666006

**Email:** [hello@voidacoustics.com](mailto:hello@voidacoustics.com)



Hear. Feel. Connect.

[voidacoustics.com](http://voidacoustics.com)