

**VOID**

Hear. Feel. Connect.

[voidacoustics.com](http://voidacoustics.com)



# Venu V2 Series

More attractive and unexpected than ever

USER GUIDE V2.4

©2026 Void Acoustics Research Ltd.

This user guide is subject to change without notice.  
For the latest online version, visit: [www.voidacoustics.com](http://www.voidacoustics.com)

Void Acoustics and the Void logo are registered trademarks of Void Acoustics Research Ltd. in the United Kingdom, USA and other countries; all other Void trademarks are the property of Void Acoustics Research Ltd.

# Contents

<b>1</b>	<b>Safety and Regulations</b>	<b>4</b>	<b>6</b>	<b>Service</b>	<b>31</b>
1.1	Important Safety Instructions	4	6.1	Return Authorisation	31
1.2	Limitations	4	6.2	Shipping and Packing Considerations	31
1.3	EC Declaration of Conformity	4			
1.4	UKCA Conformity	4	7	Appendix A: Specifications	32
1.5	Warranty Statement	4	8	Appendix B: Dimensions	45
1.6	WEEE Directive	4	9	Appendix C: Architectural Specifications	52
1.7	Speaker Pole Mount Warning	4	10	Appendix D: Bracket Matrix	65
<b>2</b>	<b>Unpacking and Checking</b>	<b>5</b>			
<b>3</b>	<b>About</b>	<b>6</b>			
3.1	Welcome	6			
3.2	Venu V2 Series Overview	6			
<b>4</b>	<b>Cable and Wiring</b>	<b>7</b>			
4.1	Electrical Safety	7			
4.2	Cable Considerations for Fixed Installations	7			
4.3	Phoenix Connector	7			
4.4	Venu 6, 8, 10, 12, 14 and 15 V2 wiring	8			
4.5	Venu 112, 115 and 118 V2 wiring	9			
4.6	Venu 212, 215 and 218 V2 wiring	9			
4.7	Venu 208 wiring	10			
4.8	Venu V2 amplifier to Phoenix wiring	10			
4.9	Venu V2 amplifier to 4-pin locking connector wiring	11			
<b>5</b>	<b>Mounting</b>	<b>12</b>			
5.1	Installation Safety	12			
5.2	Wall Mounting in Portrait Mode	13			
5.3	Wall Mounting in Landscape Mode	15			
5.4	High Frequency Enclosure Ceiling Mount	17			
5.5	Yoke Bracket Mounting	19			
5.6	Horn Rotation	21			
5.7	Low Frequency Enclosure Wall Mount	27			
5.8	Low Frequency Enclosure Ceiling Mount	28			
5.9	Top Hat Installation for Low Frequency Enclosures	29			
5.10	Top Hat Installation for High Frequency Enclosures	30			

# 1 Safety and Regulations

## 1.1 Important safety instructions



The lightning flash with an arrowhead symbol within an equilateral triangle is intended to alert the user to the presence of uninsulated "dangerous voltage" within the product's enclosure that may be of sufficient magnitude to constitute a risk of electric shock to persons.



The exclamation point within an equilateral triangle is intended to alert the user of the presence of important operating and maintenance (servicing) instructions in the literature accompanying the appliance.

## Safety instructions - read this first

1. Read these instructions.
2. Keep these instructions.
3. Heed all warnings.
4. Follow all instructions.
5. Do not use this apparatus near water.
6. Clean only with a dry cloth.
7. Do not block any ventilation openings. Install in accordance with the manufacturer's instructions.
8. Do not install near any heat source such as radiators, heat registers, stoves, or other such apparatus that produce heat.
9. Do not defeat the safety purpose of the grounding-type plug. A grounding type plug has two blades and a third grounding prong. The third prong is provided for your safety. If the provided plug does not fit into your outlet, consult an electrician for replacement of the obsolete outlet.
10. Protect power cords from being walked on or pinched particularly at plugs, convenience receptacles, and the point where they exit the apparatus.
11. Only use attachments and accessories specified by Void Acoustics.
12. Only use with the cart, stand, tripod, bracket, or table specified by the manufacturer, or sold with the apparatus. When a cart is used, use caution when moving the cart/apparatus combination to avoid injury from tip-over.
13. Unplug the apparatus during lightning storms or when unused for long periods of time.
14. Refer all servicing to qualified service personnel. Servicing is required when the apparatus has been damaged in any way, such as when the power-supply cord or plug is damaged, liquid has been spilled or objects have fallen into the apparatus, the apparatus has been exposed to rain or moisture, does not operate normally, or has been dropped.
15. Since the mains power supply cord attachment plug is used to disconnect the device, the plug should always be easily accessible.
16. Void loudspeakers can produce sound levels capable of causing permanent hearing damage from prolonged exposure. The higher the sound level, the less exposure needed to cause such damage. Avoid prolonged exposure to the high sound levels from the loudspeaker.

## 1.2 Limitations

This guide is provided to help familiarise the user with the loudspeaker system and its accessories. It is not intended to provide comprehensive electrical, fire, mechanical and noise training and is not a substitute for industry-approved training. Nor does this guide absolve the user of their obligation to comply with all relevant safety legislation and codes of practice. While every care has been taken in creating this guide, safety is user-dependent and Void Acoustics Research Ltd cannot guarantee complete safety whenever the system is rigged and operated.

## 1.3 EC declaration of conformity

For EC Declaration of Conformity please go to:

[www.voidacoustics.com/eu-declaration-loudspeakers](http://www.voidacoustics.com/eu-declaration-loudspeakers)

## 1.4 UKCA marking

For details of the UKCA marking go to:

[www.voidacoustics.com/uk-declaration-loudspeakers](http://www.voidacoustics.com/uk-declaration-loudspeakers)

## 1.5 Warranty statement

For warranty statement go to:

<https://voidacoustics.com/terms-conditions/>

## 1.6 WEEE directive

If the time arises to throw away your product, please recycle all the components possible.



This symbol indicates that when the end-user wishes to discard this product, it must be sent to separate collection facilities for recovery and recycling. By separating this product from other household-type waste, the volume of waste sent to incinerators or land-fills will be reduced and natural resources will thus be conserved.

The Waste Electrical and Electronic Equipment Directive (WEEE Directive) aims to minimise the impact of electrical and electronic goods on the environment. Void Acoustics Research Ltd complies with the Directive 2002/96/EC and 2003/108/EC of the European Parliament on waste electrical and electronic equipment (WEEE) in order to reduce the amount of WEEE that is being disposed of in land-fill sites. All of our products are marked with the WEEE symbol; this indicates that this product must NOT be disposed of with other waste. Instead it is the user's responsibility to dispose of their waste electrical and electronic equipment by handing it over to an approved reprocessor, or by returning it to Void Acoustics Research Ltd for reprocessing. For more information about where you can send your waste equipment for recycling, please contact Void Acoustics Research Ltd or one of your local distributors.

## 1.7 Speaker Pole Mount Warning



M20 top hats are designed to support a maximum centric load of 35 kgs and not suitable for mounting heavier products such as the Air Motion or Tri Motion. Always place the base of the subwoofer on a flat and stable surface. The stability of the system depends on the height of the pole, and the size and weight of the speakers. It is the responsibility of the user to ensure the assembled system is secure and stable. Misuse could lead to injury or equipment damage. Always make sure that the M20 pole is fully fastened into the threaded top hat, damaged is likely to occur if not secured tightly.



## 2 Unpacking and Checking

All Void Acoustics products are carefully manufactured and thoroughly tested before being despatched. Your dealer will ensure that your Void products are in pristine condition before being forwarded to you but mistakes and accidents can happen.

Before signing for your delivery:

- Inspect your shipment for any signs of contamination, abuse or transit damage as soon as you receive it
- Check your Void Acoustics delivery fully against your order
- If your shipment is incomplete or any of its contents are found to be damaged; inform the shipping company and inform your dealer.

When you are removing your Venu V2 loudspeaker from its original packaging:

- All Venu V2 loudspeakers come double boxed and each box is stapled shut; take care when unboxing and removing the staples to avoid injury or damage to the loudspeaker
- If you need to place the Venu V2 loudspeaker on a flat surface ensure you use a lint free product to protect the finish
- When you have removed the Venu V2 loudspeaker from the packaging inspect it to ensure there is no damage and keep all original packaging in case it needs to be returned for any reason.

See section 1.5 for warranty conditions and see section 6 if your product needs servicing.

# 3 About

## 3.1 Welcome

Many thanks for purchasing this Void Acoustics Venu V2 Series loudspeaker. We truly appreciate your support. At Void, we design, manufacture and distribute advanced professional audio systems for the installed and live sound market sectors. Like all Void products, our highly skilled and experienced engineers have successfully combined pioneering technologies with ground-breaking design aesthetics, to bring you superior sound quality and visual innovation. In buying this product, you are now part of the Void family and we hope using it brings you years of satisfaction. This guide will help you both use this product safely and ensure it performs to its full capability.

## 3.2 Venu V2 Series overview

The Venu V2 series is an installation range available with passive and active subwoofer options. Designed for flexible system deployment across various venue sizes, the Venu V2 series feature custom RAL finishes, rotatable horns and badges, flexible mounting and bracketry options, using 4-pin locking connector or link-through Phoenix Connector inputs to support system expansion.

Passive two-way surface mount loudspeakers:

- Venu 6 V2
- Venu 8 V2
- Venu 10 V2
- Venu 12 V2
- Venu 14 V2
- Venu 15 V2

Low frequency loudspeakers:

- Venu 208
- Venu 112 V2
- Venu 212 V2
- Venu 115 V2
- Venu 215 V2
- Venu 118 V2
- Venu 218 V2

# 4 Cable and Wiring

## 4.1 Electrical safety



To avoid electrical hazards please note the following:

- Do not access the inside of any electrical equipment. Refer servicing to Void-approved service agents.

## 4.2 Cable considerations for fixed installations

We recommend specifying installation-grade Low Smoke Zero Halogen (LSZH) cables for permanent installations. The cables should use Oxygen Free Copper (OFC) of grade C11000 or above. Cables for permanent installations should be compliant with the following standards:

- IEC 60332.1 Fire retardancy of a single cable
- IEC 60332.3C Fire retardancy of bunched cables
- IEC 60754.1 Amount of Halogen Gas Emissions
- IEC 60754.2 Degree of acidity of released gases
- IEC 61034.2 Measurement of smoke density.

We suggest using the following maximum copper cable lengths to keep level losses below 0.6 dB.

Metric mm <sup>2</sup>	Imperial AWG	8 $\Omega$ load	4 $\Omega$ load	2 $\Omega$ load
2.50 mm <sup>2</sup>	13 AWG	36 m	18 m	9 m
4.00 mm <sup>2</sup>	11 AWG	60 m	30 m	15 m

## 4.3 Phoenix connector

Figure 4.1 shows the rear panel of a Venu Series V2 loudspeaker with the polarity of the Phoenix connector labelled. From left to right it is - and + for the feed to the drivers and the - and + for the link/out.

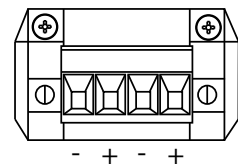

Figure 4.1: Phoenix connector polarity

# 4 Cable and Wiring

## 4.4 Venu 6, 8, 10, 12, 14 and 15 V2 wiring

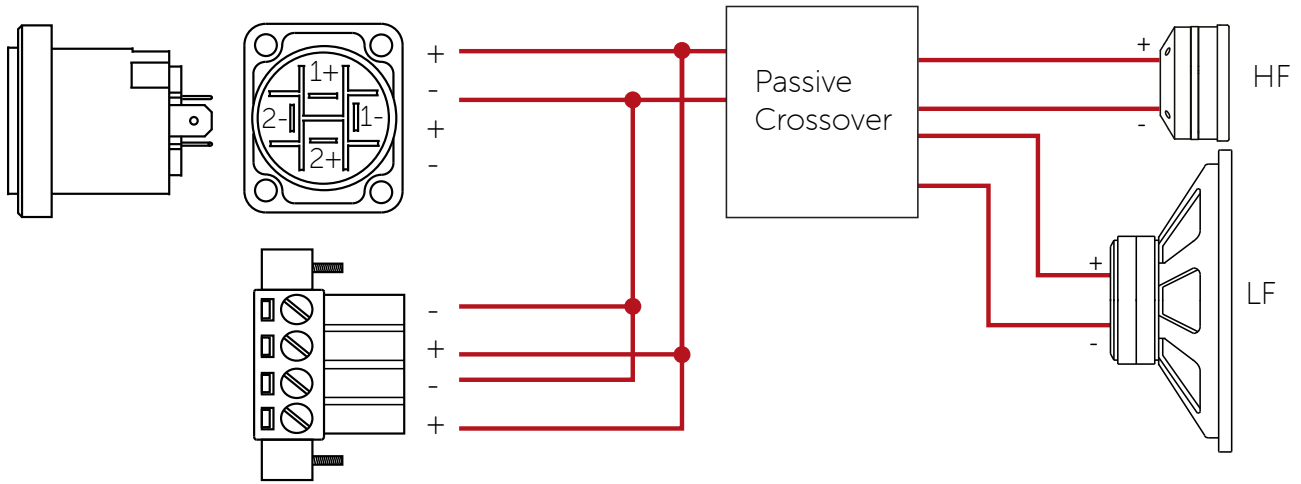

Figure 4.2: Loudspeaker wiring diagram

	4-pin locking connector pins 1+/1-
Venu 6 V2	1" HF and 6.5" LF
Venu 8 V2	1" HF and 8" LF
Venu 10 V2	1" HF and 10" LF
Venu 12 V2	1" HF and 12" LF
Venu 14 V2	1.4" HF and 13.5" LF
Venu 15 V2	1" HF and 15" LF

# 4 Cable and Wiring

## 4.5 Venu 112, 115 and 118 V2 wiring

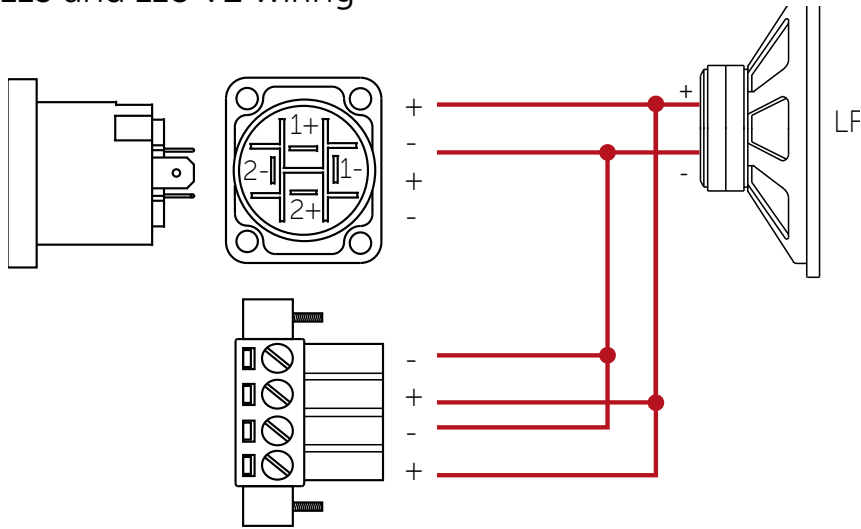

Figure 4.3: Single low frequency loudspeaker wiring diagram

	4-pin locking connector pins 1+/1-
Venu 112 V2	12" LF
Venu 115 V2	15" LF
Venu 118 V2	18" LF

## 4.6 Venu 212, 215 and 218 V2 wiring

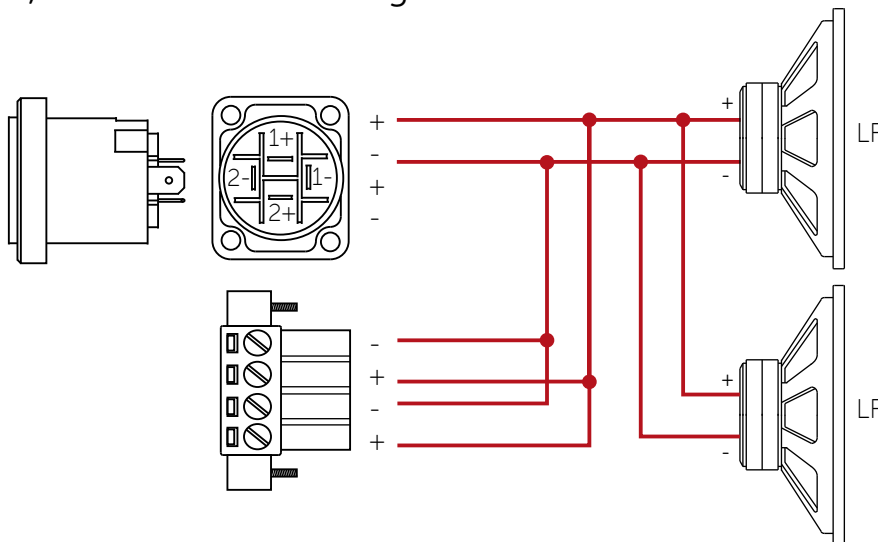

Figure 4.4: Dual low frequency loudspeaker wiring diagram

	4-pin locking connector pins 1+/1-
Venu 212 V2	2 x 12" LF
Venu 215 V2	2 x 15" LF
Venu 218 V2	2 x 18" LF

# 4 Cable and Wiring

## 4.7 Venu 208 wiring

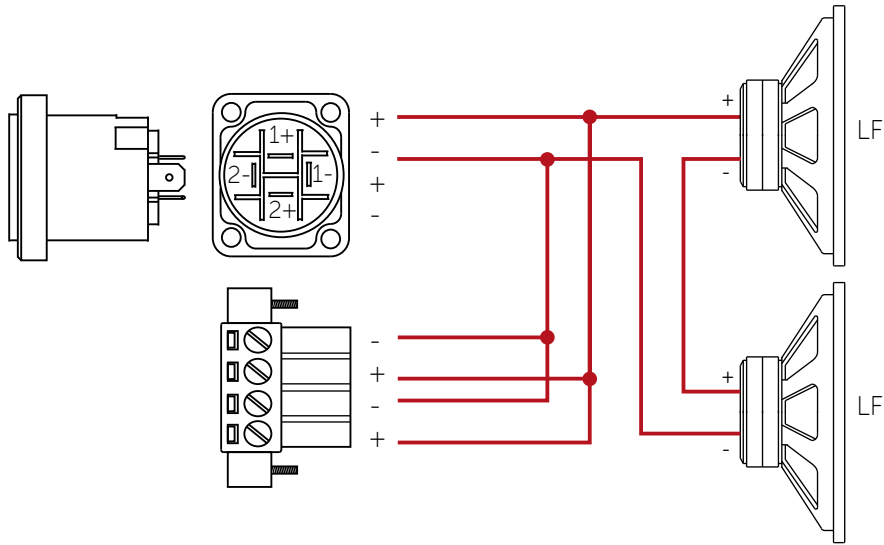

Figure 4.5: Venu 208 wiring diagram

	4-pin locking connector pins 1+/1-
Venu 208 V2	2 x 8" LF

## 4.8 Venu V2 amplifier to Phoenix wiring

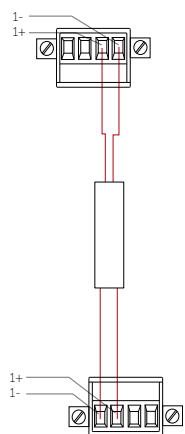
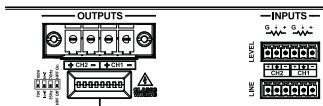

Figure 4.6: Bias D1 Phoenix wiring

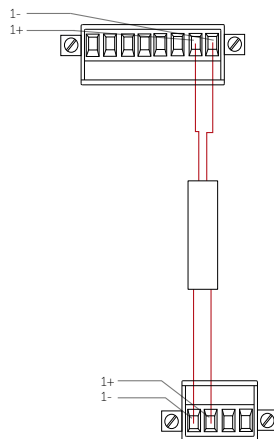
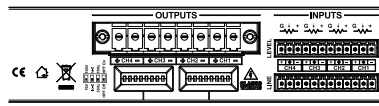

Figure 4.7: Bias Q1/Q1.5/Q2 Phoenix wiring

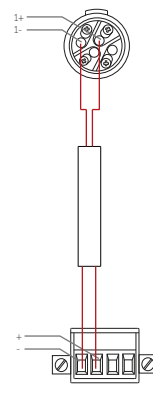
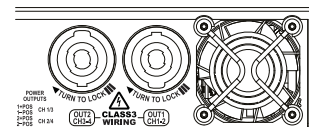

Figure 4.8: Bias Q3/Q5 4-pin locking connector wiring

# 4 Cable and Wiring

## 4.9 Venu V2 amplifier to 4-pin locking connector wiring

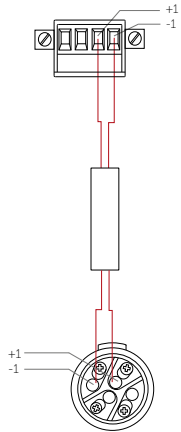
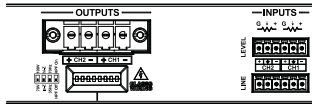

Figure 4.9: Bias D1 Phoenix wiring

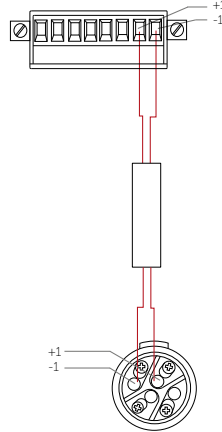
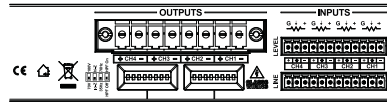

Figure 4.10: Bias Q1/Q1.5/Q2 Phoenix wiring

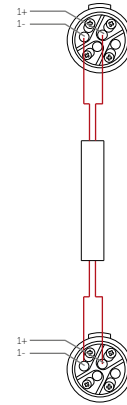
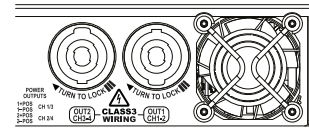

Figure 4.11: Bias Q3/Q5 4-pin locking connector wiring

Bias D1/Q1/Q1.5/Q2/Q3/Q5	Output 1
Max parallel units (Venu 6/8/10/12/14/15/112/115/118/208 V2)	4 (2 $\Omega$ load to amplifier)
Max parallel units (Venu 212/215/218 V2)	2 (2 $\Omega$ load to amplifier)



Connecting a 4-pin locking connector cable directly from a Bias Q5 to a Venu V2 loudspeaker will short circuit the amplifier and cause it to go into protect. Use either a 2-pin locking connector cable or a patch panel to split the amplifier channels.

Connecting a 4-pin locking connector cable directly from a Bias Q5 to a Venu V2 loudspeaker will short circuit the amplifier and cause it to go into protect. Use either a 2-pin locking connector cable or a patch panel to split the amplifier channels.

# 5 Mounting

## 5.1 Installation safety

To avoid mechanical hazards, please note the following:



- Safety regulations vary in different regions. Full compliance with those regulations must be your priority
- Installations must only be undertaken by fully qualified and experienced engineers/technicians who understand local regulations
- This may include consulting a structural engineer before installation of wall brackets
- Remember that all personnel have a duty of care to themselves, to their assistants, to the venue staff and to the public
- Before lifting any part of the system above head height, check the whole rig for loose tools or other items that may fall and cause injury
- Do not use a telephone (even if hands-free) whilst installing. Always concentrate fully on the installation operation
- Do not install equipment that is worn, damaged, corroded, mishandled or over-stressed in any way
- Use only Void-approved mounting equipment and accessories
- Secondary safeties should be provided in all instances where cabinets are flying or fixing overhead and should conform to local regulations

## 5.2 Wall Mounting in Portrait Mode

Parts required (see Appendix D for part numbers):

- T80 wall bracket (Venu 6, 8 V2)
- T80XL wall bracket (Venu 10, 12, 14, 15 V2)

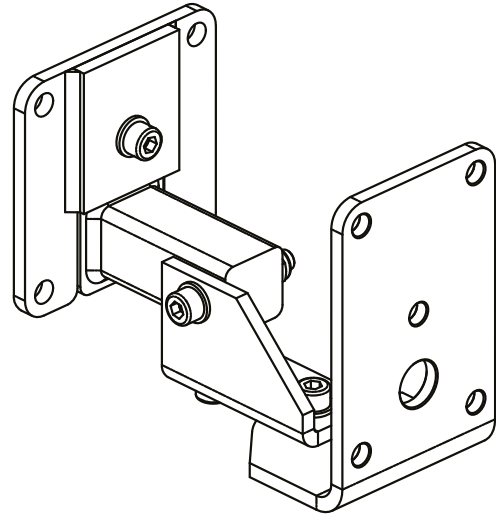

Figure 5.1: T80 wall bracket

Step 1:  
Remove all four M8 bolts from the rear of the loudspeaker.

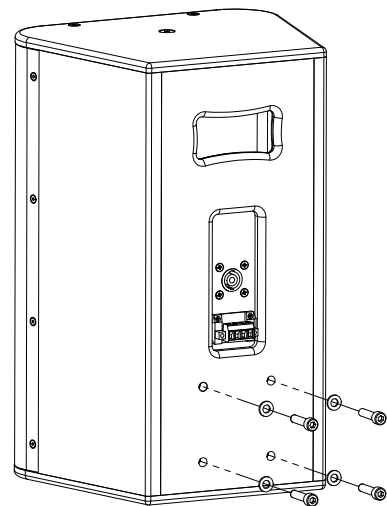

Figure 5.2: Venu bolt removal

Step 2:  
Remove the front of the bracket from the main bracket assembly. Attach the rear of the bracket assembly to the wall making sure all 4 bolts are fitted.



Take care when mounting the bracket to the wall, making sure to use the correct fixing and that the wall can take the load.

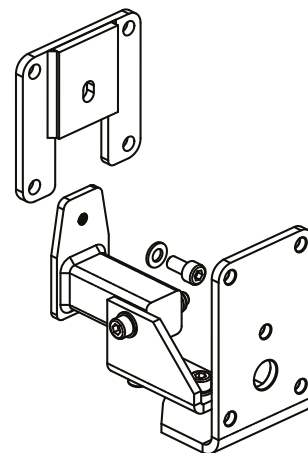

Figure 5.3: De-constructing the bracket assembly

# 5.2 Wall Mounting in Portrait Mode

Step 3:  
Attach the front of the bracket assembly to the rear of the loudspeaker using all four M8 bolts.

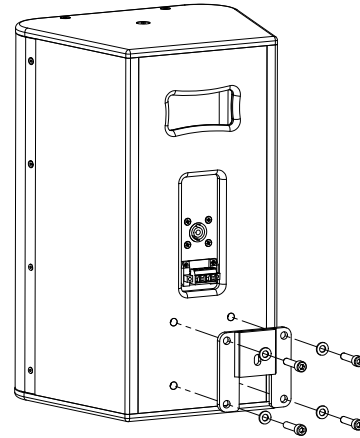

Figure 5.4: Attaching bracket to loudspeaker

Step 4:  
Lower the speaker assembly on to the rear of the bracket assembly and fix the bolt into the rear of assembly.

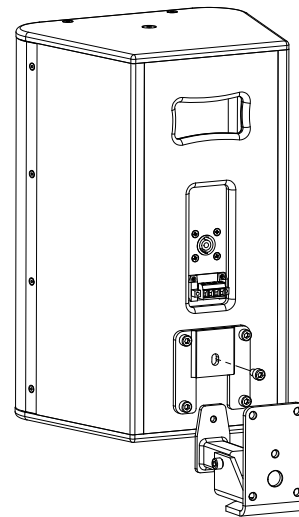

Figure 5.5: Attaching loudspeaker to bracket

Step 5:  
Adjust the bracket in the horizontal axis by loosening the bolt at the rear of the assembly (figure 5.6a) and in the vertical axis by adjusting the bolt on the base of the assembly (figure 5.6b).

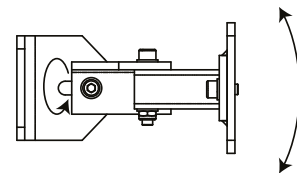

Figure 5.6a: Bracket adjustment

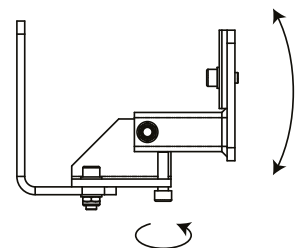

Figure 5.6b: Bracket adjustment

	Maximum rotation	
	Horizontal	Vertical
Venu 6	76°	40°
Venu 8	70°	40°
Venu 10	63°	40°
Venu 12	72°	40°
Venu 14	60°	40°
Venu 15	61°	40°

## 5.3 Wall Mounting in Landscape Mode

Parts required (see Appendix D for part numbers):

- T80 wall bracket (Venu 6, 8 V2)
- T80XL wall bracket (Venu 10, 12, 14, 15 V2)

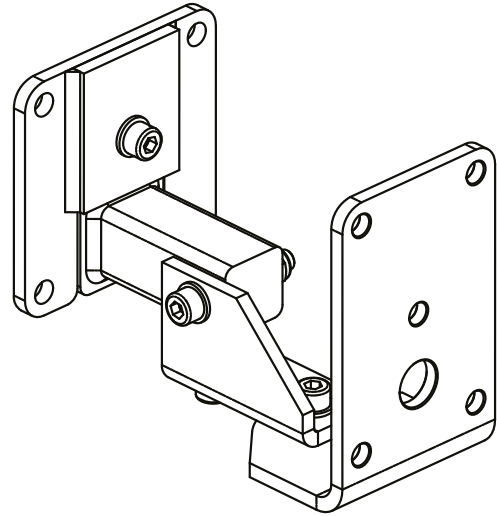

Figure 5.7: T80 wall bracket

**Step 1:**  
After rotating the horn, as described in section 5.6, remove all four M8 bolts from the rear of the loudspeaker.

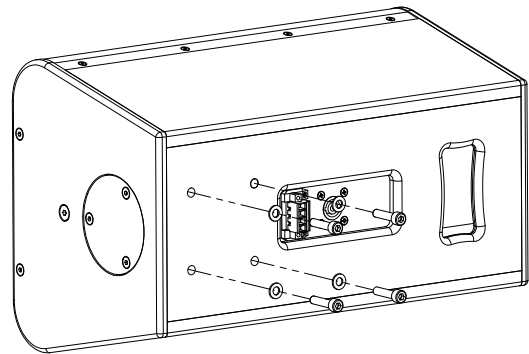

Figure 5.8: Venu bolt removal

**Step 2:**  
Remove the front of the bracket from the main bracket assembly. Attach the rear of the bracket assembly to the wall making sure all 4 bolts are fitted.



Take care when mounting the bracket to the wall, making sure to use the correct fixing and that the wall can take the load.

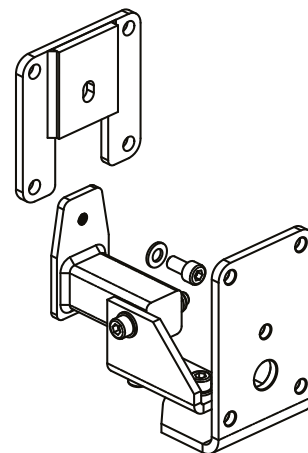

Figure 5.9: De-constructing the bracket assembly

# 5.3 Wall Mounting in Landscape Mode

Step 3:

Attach the front of the bracket assembly to the rear of the loudspeaker using all four M8 bolts.

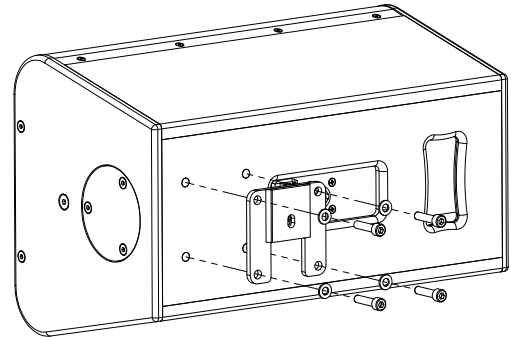

Figure 5.10: Attaching bracket to loudspeaker

Step 4:

Lower the speaker assembly on to the rear of the bracket assembly and adjust the bracket so that loudspeaker is in the required position.

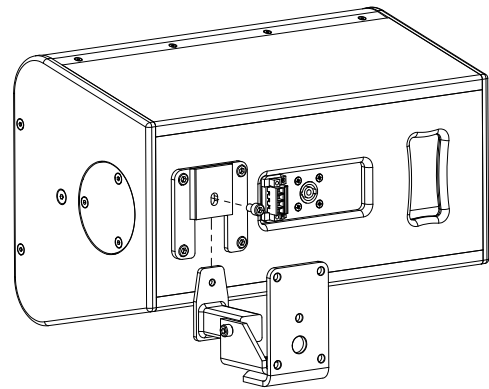

Figure 5.11: Loudspeaker positioning

Step 5:

Adjust the bracket in the horizontal axis by loosening the bolt at the rear of the assembly (figure 5.12a) and in the vertical axis by adjusting the bolt on the base of the assembly (figure 5.12b).

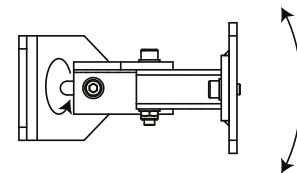

Figure 5.12a: Bracket adjustment

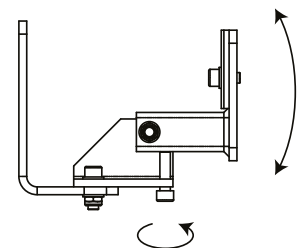

Figure 5.12b: Bracket adjustment

	Maximum rotation	
	Horizontal	Vertical
Venu 6	65°	40°
Venu 8	56°	40°
Venu 10	85°	40°
Venu 12	65°	40°
Venu 14	70°	40°
Venu 15	33°	40°

# 5.4 High Frequency Enclosure Ceiling Mount

Parts required (see Appendix D for part numbers):

- T80 - Ceiling Bracket (350mm)

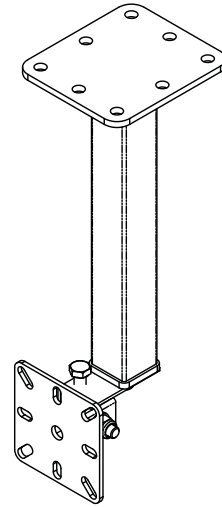

Figure 5.13: T80 - Ceiling Bracket

Step 1:  
Remove all the M12 bolt from the bracket.

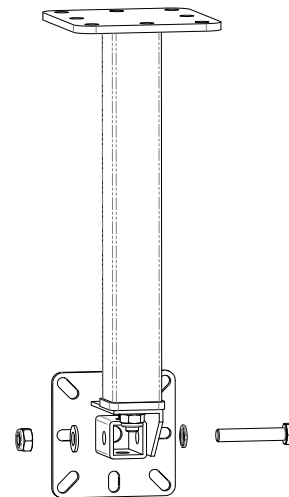

Figure 5.14: Venu bolt removal

Step 2:  
Remove all four M8 bolts from the rear of the loudspeaker. Attach the bracket plate using all four M8 bolts.

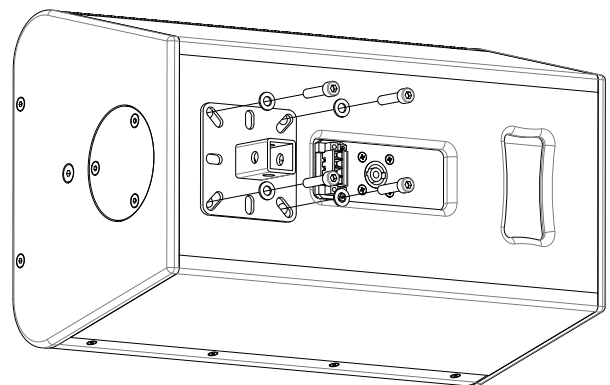

Figure 5.15: Fixing bracket

## 5.4 High Frequency Enclosure Ceiling Mount

### Step 3:

With the bracket in position raise the loudspeaker into position and reattach the M12 bolt.



Take care when mounting the bracket to the ceiling, making sure to use the correct fixing and that the ceiling can take the load,

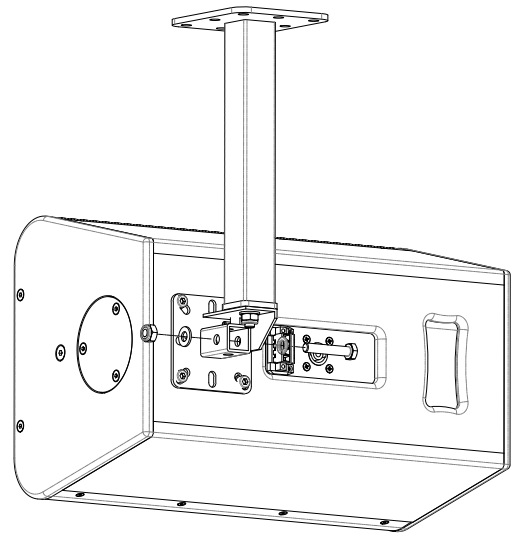

Figure 5.16: Attaching bracket to loudspeaker

### Step 4:

Tighten the M10 bolt on the bracket to fix the loudspeaker in position. Maximum vertical adjustment is 32°.

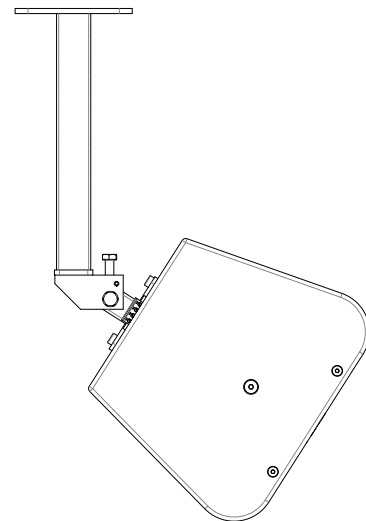

Figure 5.17: Loudspeaker positioning

# 5.5 Yoke Bracket Mounting

Parts required (see Appendix D for part numbers):

- Venu series yoke bracket (Venu 6, 8, 10, 12, 14, 15, 112, 212, 115, 208 V2)

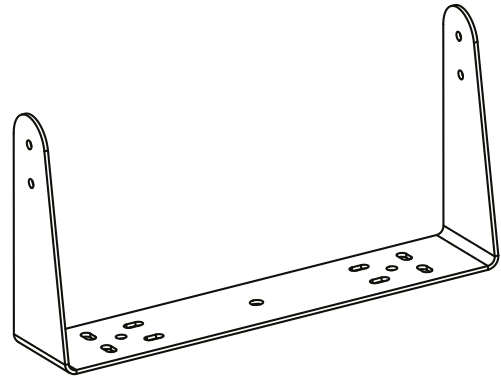

Figure 5.18: Venu series yoke bracket

**Step 1:**  
Begin by fixing the yoke by the central bolt hole and adjusting the position until the yoke is in the required position.

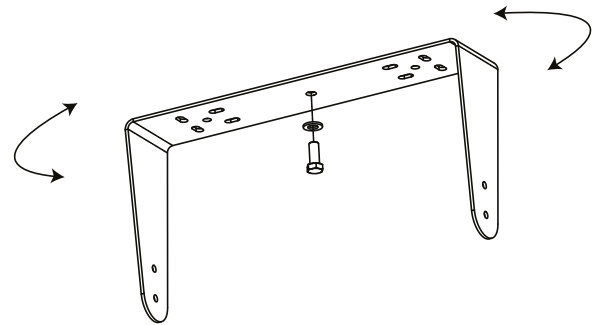

Figure 5.19: Yoke adjustment

**Step 2:**  
Fix the yoke into position by fitting the remaining bolts.



Take care when mounting the yoke to the wall/ceiling, making sure to use the correct fixing and that it can take the load.

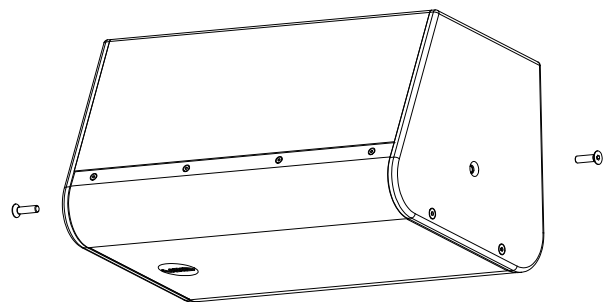

Figure 5.20: Yoke fixing

## 5.5 Yoke Bracket Mounting

### Step 3:

Remove the countersunk M8 bolts from the top and bottom of the loudspeaker.

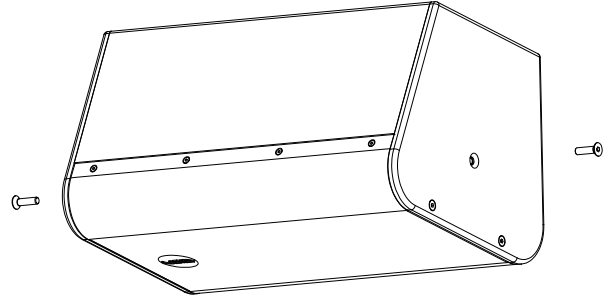

Figure 5.21: Venu series yoke bracket

### Step 4:

Lift the loudspeaker into position. Do NOT use the countersunk M8 bolts from the Venu loudspeaker but instead use the M8 bolts supplied with the yoke bracket. Fit the M8 bolts but do not tighten.

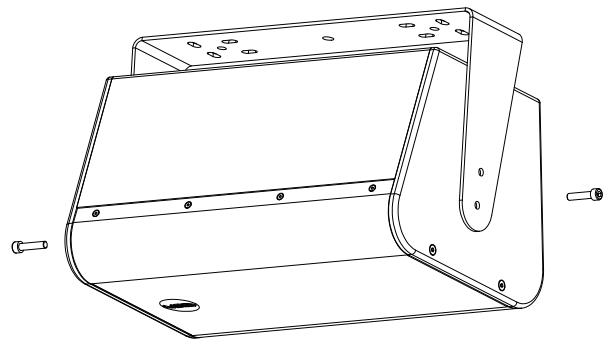

Figure 5.22: Loudspeaker fitting

### Step 5:

Rotate the loudspeaker into position and then tighten the bolts.

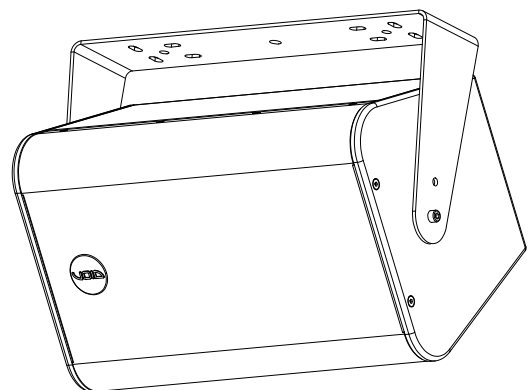

Figure 5.23: Loudspeaker positioning

# 5.6 Horn Rotation

## 5.6.1 Venu 6, 8, 10, 12, 15 V2

Step 1:  
Remove all eight M4 bolts from the side of the cabinet

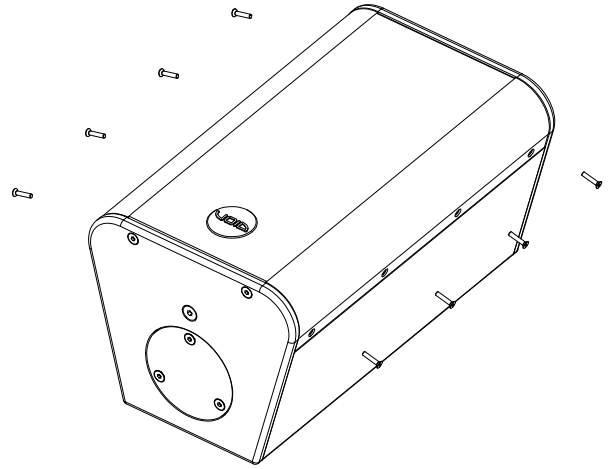

Figure 5.24: Remove M4 bolts

Step 2:  
Loosen, but do not remove the four M6 bolts at the top and bottom of cabinet and carefully remove the grille.

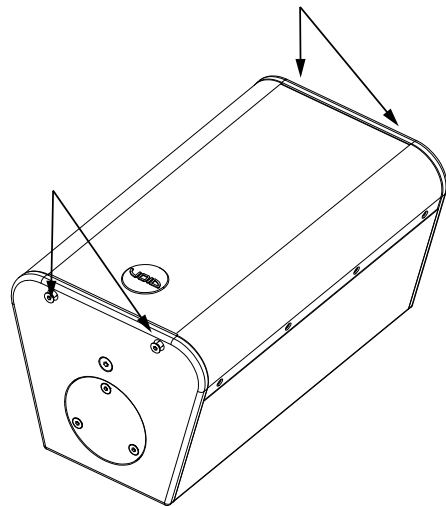

Figure 5.25: Grille removal

Step 3:  
Remove all four M5 bolts from around the horn.

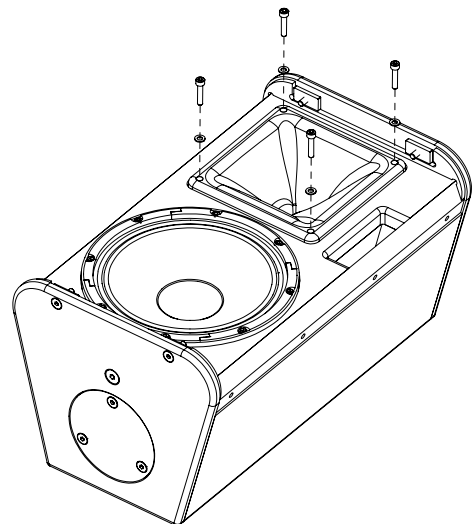

Figure 5.26: Removing horn screws

## 5.6 Horn Rotation

Step 4:

Rotate the horn and return it to its position within the enclosure and redo all four bolts.

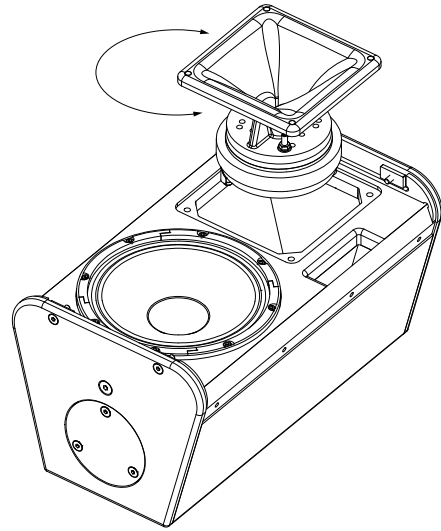

Figure 5.27: Rotating horn

Step 5:

Replace the grille and tighten the M6 bolts at the top and bottom of the cabinet and insert all eight M4 bolts in the side.

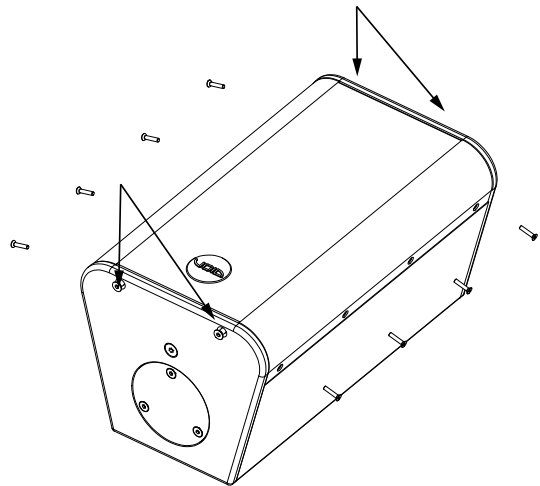

Figure 5.28: Grille replacement

Step 6:

Rotate the badge to the desired orientation by lifting and turning 90°. The badge will locate automatically once in position.

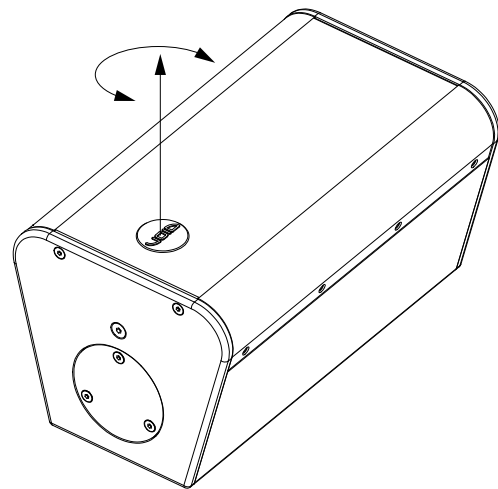

Figure 5.29: Badge rotation

# 5.6 Horn Rotation

## 5.6.2 Venu 14 V2

Step 1:  
Remove all eight M4 bolts from the side of the cabinet

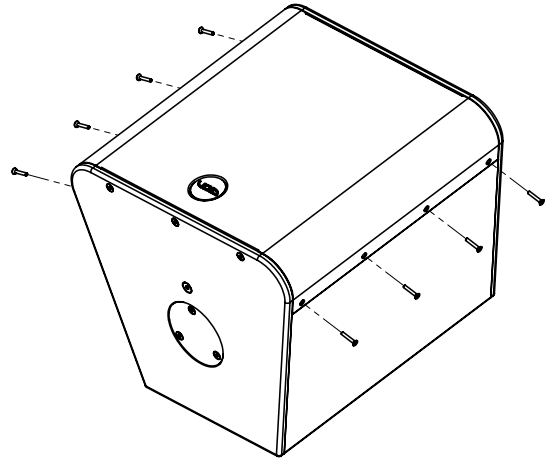

Figure 5.30: Remove M4 bolts

Step 2:  
Loosen, but do not remove the four M6 bolts at the top and bottom of cabinet and carefully remove the grille.

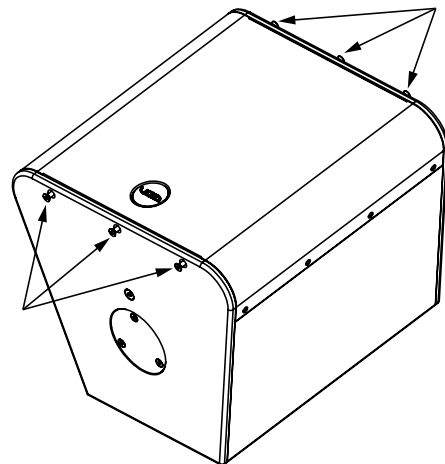

Figure 5.31: Grille removal

Step 3:  
Remove all eight M5 bolts from around the driver.

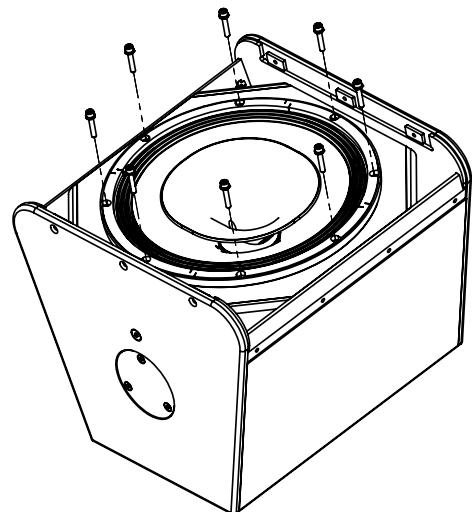

Figure 5.32: Removing horn screws

## 5.6 Horn Rotation

Step 4:

Rotate the driver 90° and return it to its position within the enclosure and redo all eight bolts.

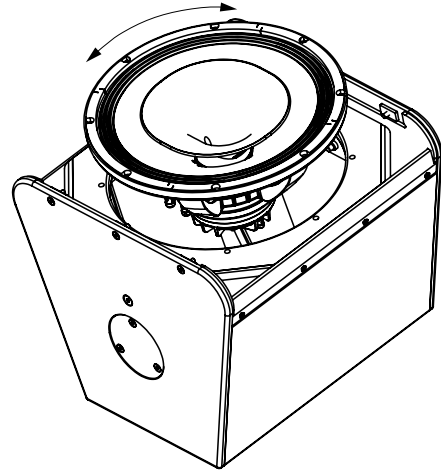

Figure 5.33: Rotating horn

Step 5:

Replace the grille and tighten the M6 bolts at the top and bottom of the cabinet and insert all eight M4 bolts in the side.

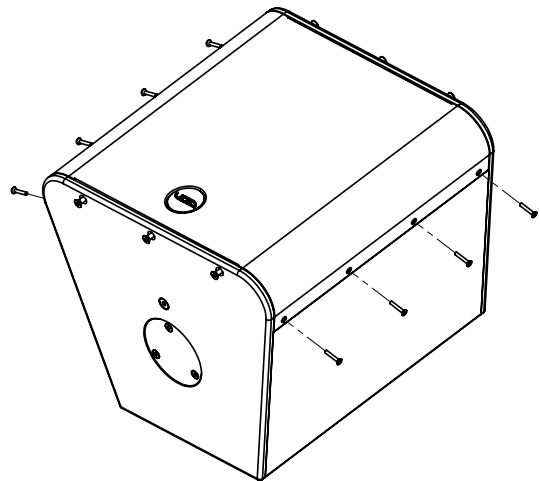

Figure 5.34: Grille replacement

Step 6:

Rotate the badge to the desired orientation by lifting and turning 90°. The badge will locate automatically once in position.

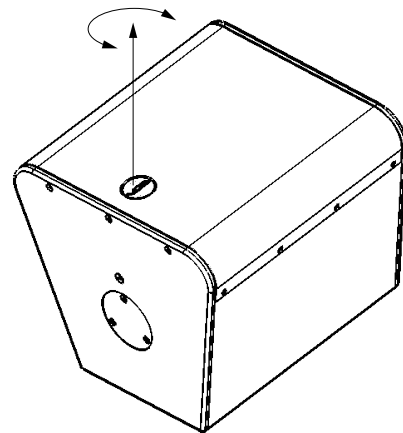

Figure 5.35: Badge rotation

# 5.7 Low Frequency Enclosure Wall Mount

For use with:  
Venu 112/115/208 V2

Part required (see Appendix D for part numbers):  
T75 - Wall Bracket

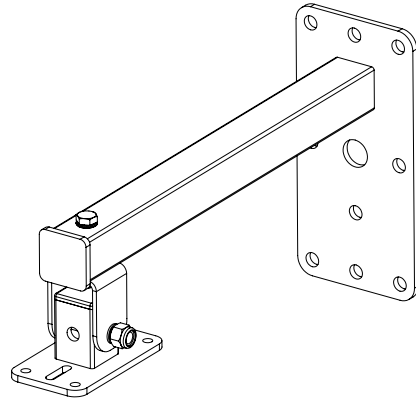

Figure 5.36: T75 - Wall Bracket

Step 1:  
Remove the type 75 plate from the T75 - Wall Bracket by removing the M12 bolt.



Take care when mounting the WHD75 to the wall, making sure to use the correct fixing and that it can take the load.

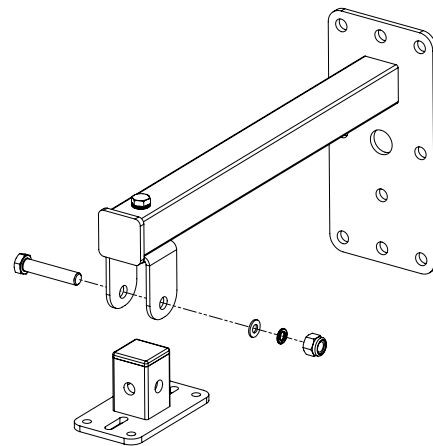

Figure 5.37: Nut removal

Step 2:  
Remove all four M8 countersunk bolts from the bottom of the loudspeaker

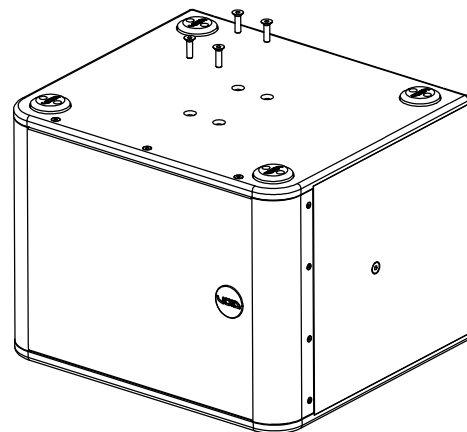

Figure 5.38: Bolt removal

## 5.7 Low Frequency Enclosure Wall Mount

Step 4:

Attach the type 75 plate to the loudspeaker using the M8 socket cap bolts supplied with the bracket.

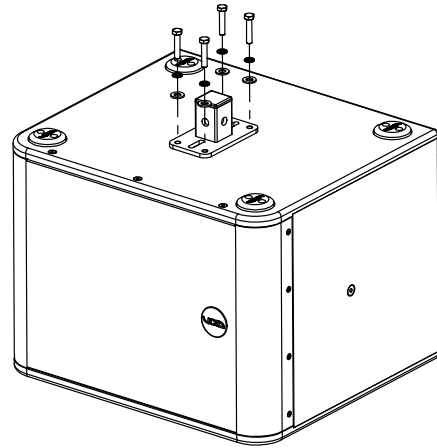

Figure 5.39: Attaching the type 75 plate

Step 5:

Raise the loudspeaker into position and attach the M12 nut.

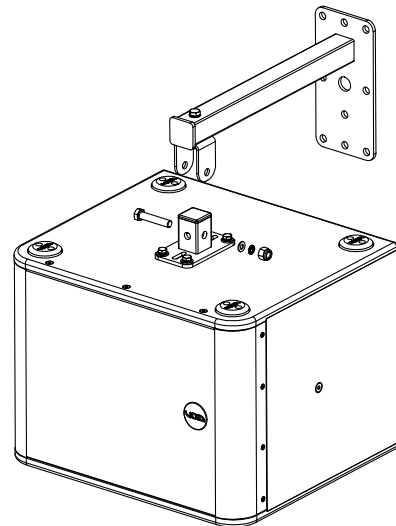

Figure 5.40: Loudspeaker fixing

Step 6:

Rotate the loudspeaker into the desired position and tighten the M12 bolt.

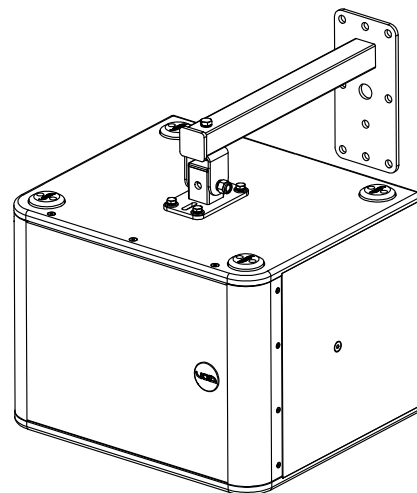

Figure 5.41: Loudspeaker positioning

# 5.8 Low Frequency Enclosure Ceiling Mount

For use with:  
Venu 112/115/208 V2

Part required (see Appendix D for part numbers):  
T75 - Ceiling Bracket

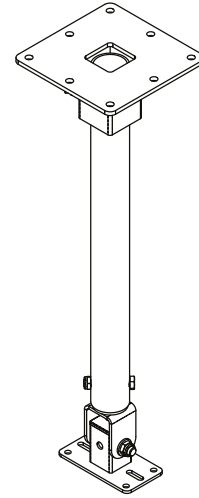

Figure 5.42: T75 - Ceiling Bracket

Step 1:  
Remove the type 75 plate from the T75 - Ceiling Bracket by removing the M12 bolt.

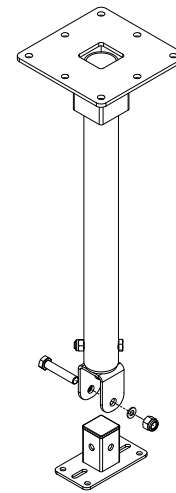

Figure 5.43: Nut removal

Step 2:  
Remove all four M8 counter sink bolts from the bottom of the loudspeaker

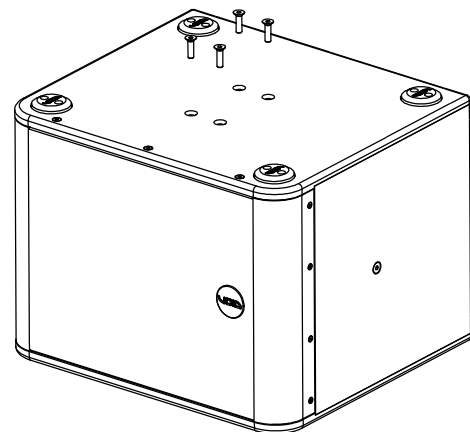

Figure 5.44: Bolt removal

## 5.8 Low Frequency Enclosure Ceiling Mount

Step 4:

Attach the type 75 plate to the loudspeaker using the M8 socket cap bolts supplied with the bracket.

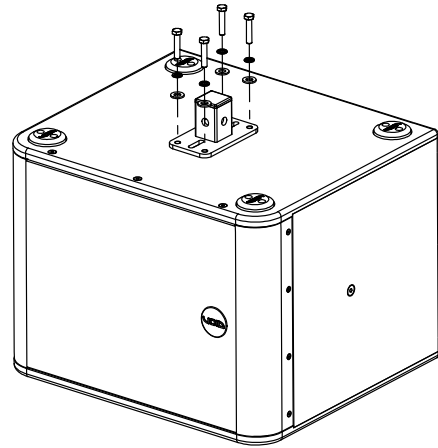

Figure 5.45: Attaching the type 75 plate

Step 5:

Raise the loudspeaker into position and attach the M12 nut.

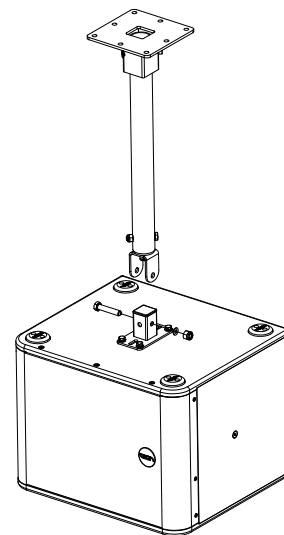

Figure 5.46: Loudspeaker fixing

Step 6:

Rotate the loudspeaker into the desired position and tighten the M12 bolt.

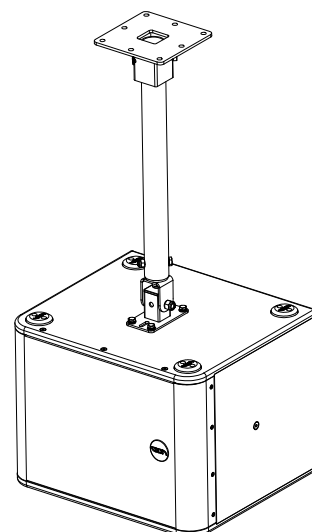

Figure 5.47: Loudspeaker positioning

# 5.9 Top Hat Installation for Low Frequency Enclosures

For use with:  
Venu 112/212/115/215/118/218 V2

Part required (see Appendix D for part numbers):  
Heavy Duty Top Hat

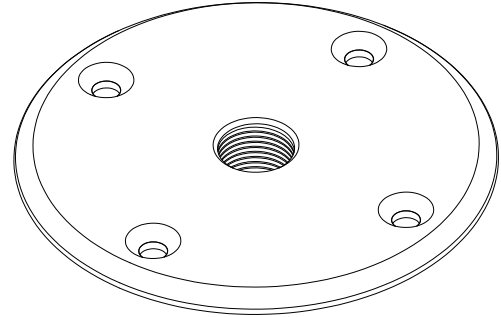

Figure 5.48: Heavy duty top hat

Step 1:  
Remove all four M6 bolts and remove the cover plate.

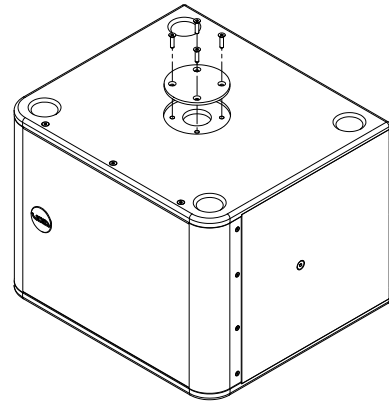

Figure 5.49: Cover plate removal

Step 2:  
Insert the Heavy Duty Top Hat and replace all four M6 bolts.

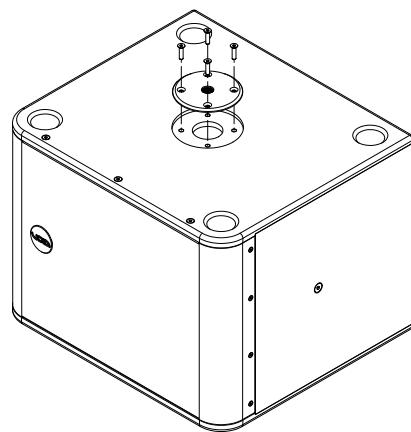

Figure 5.50: Top hat placement

# 5.10 Top Hat Installation for High Frequency Enclosures

For use with:  
Venu 6/8/10/12/14/15 V2

Part required (see Appendix D for part numbers):  
Venu V2 Top Hat

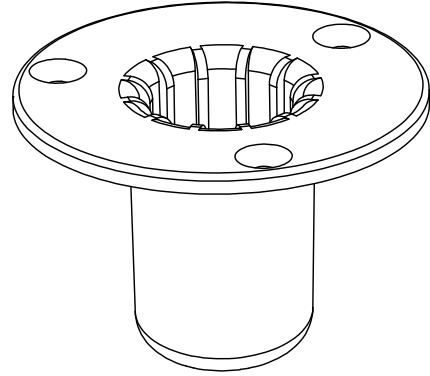

Figure 5.51: Venu V2 top hat

Step 1:  
Remove all three M6 bolts and remove the cover plate.

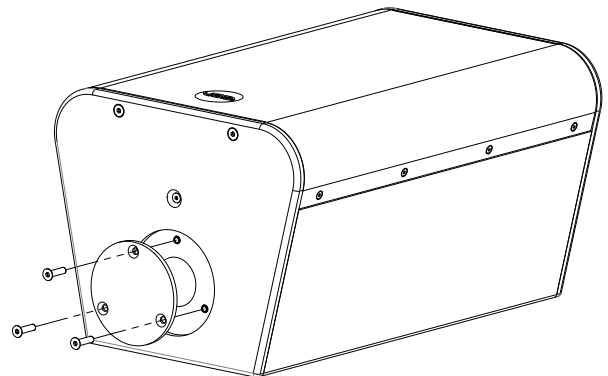

Figure 5.52: Cover plate removal

Step 2:  
Insert the Venu V2 Top Hat and replace all three M6 bolts.

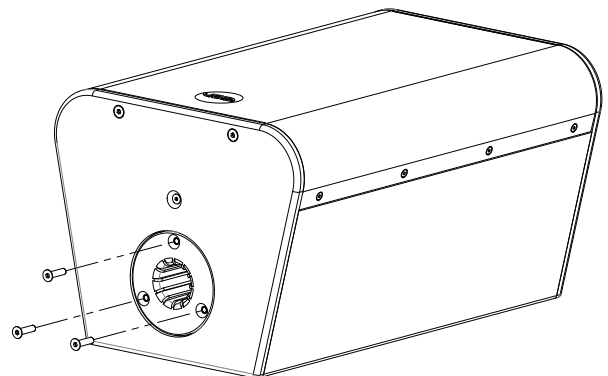

Figure 5.53: Top hat placement

# 6 Service

Void Venu V2 Series loudspeakers should only be serviced by a fully-trained technician.



No user serviceable parts inside. Refer servicing to your dealer.

## 6.1 Return authorisation

Before returning your faulty product for repair, please remember to get an R.A.N. (Return Authorisation Number) from the Void dealer who supplied the system to you. Your dealer will handle the necessary paperwork and repair. Failure to go through this return authorisation procedure could delay the repair of your product.

Note that your dealer will need to see a copy of your sales receipt as proof of purchase so please have this to hand when applying for return authorisation.

## 6.2 Shipping and packing considerations

- When sending a Void Venu V2 Series loudspeaker to an authorised service centre, please write a detailed description of the fault and list any other equipment used in conjunction with the faulty product.
- Accessories will not be required. Do not send the instruction manual, cables or any other hardware unless your dealer asks you to.
- Pack your unit in the original factory packaging if possible. Include a note of the fault description with the product. Do not send it separately.
- Ensure safe transportation of your unit to the authorised service centre.

# 7 Appendix A: Specifications

## A.1 Venu 6 V2 Specifications

Frequency Response <sup>1</sup>	68 Hz - 20 kHz
Maximum Output <sup>2</sup>	118 dB cont, 124 dB peak
Nominal Dispersion	90°H x 60°V rotatable
Sensitivity <sup>3</sup>	95 dB 1W/1m
Driver Configuration	1 x 6.5" LF, 1 x 1" HF compression driver
Power Handling	200 W AES
Nominal Impedance	8 $\Omega$
Suggested Minimum Amplifier	Bias Q1+
Weight	9.5 kg (20.9 lbs)
Connections	1 x Phoenix with link out 1 x 4-pin locking connector with link out
Enclosure	15 mm birch plywood
Finish	Textured polyurethane
Mounting	Yoke bracket 4 x M8 fixing points for Type 80 plate Optional 35mm top hat
Height	372 mm (14.6")
Width	224 mm (8.8")
Depth	202 mm (8")

<sup>1</sup> -10 dB IEC 60268-5 <sup>2</sup> Calculated <sup>3</sup> Measured in half space

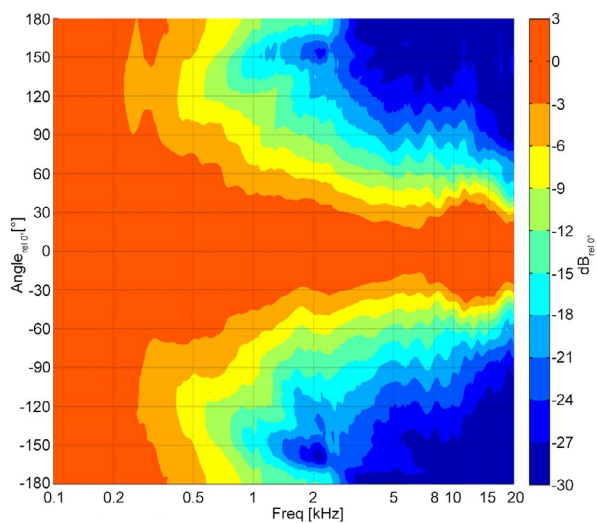

Figure A.1: Horizontal directivity isobars

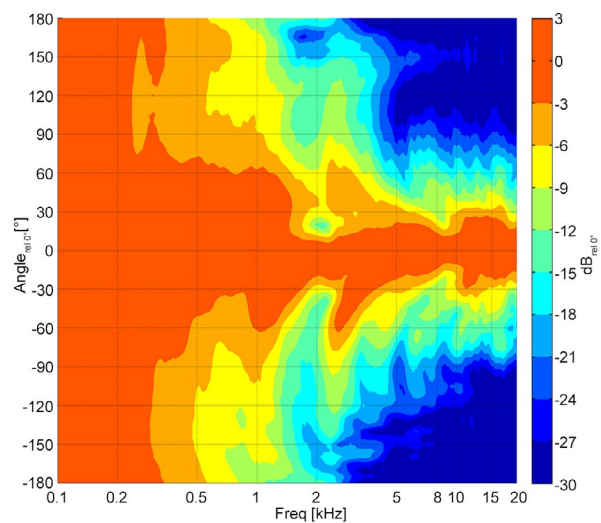

Figure A.2: Vertical directivity isobars

# 7 Appendix A: Specifications

## A.2 Venu 8 V2 Specifications

Frequency Response <sup>1</sup>	70 Hz - 20 kHz $\pm$ 3 dB
Maximum Output <sup>2</sup>	121 dB cont, 127 dB peak
Nominal Dispersion	90°/40°H x 60°V rotatable
Sensitivity <sup>3</sup>	97 dB 1W/1m
Driver Configuration	1 x 8" LF, 1 x 1" HF compression driver
Power Handling	300 W AES
Nominal Impedance	8 $\Omega$
Suggested Minimum Amplifier	Bias Q1+
Weight	12 kg (26.5 lbs)
Connections	1 x Phoenix with link out 1 x 4-pin locking connector with link out
Enclosure	15 mm birch plywood
Finish	Textured polyurethane
Mounting	Yoke bracket 4 x M8 fixing points for Type 80 plate Optional 35mm top hat
Height	415 mm (16.3")
Width	245 mm (9.6")
Depth	228 mm (9")

<sup>1</sup> -10 dB IEC 60268-5 <sup>2</sup> Calculated <sup>3</sup> Measured in half space

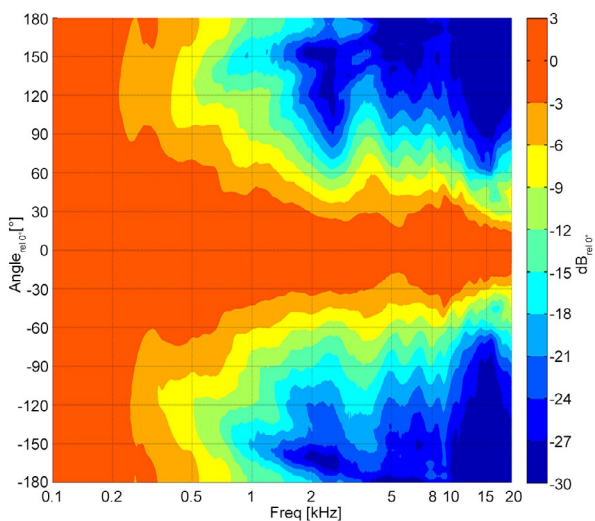

Figure A.3: Horizontal directivity isobars

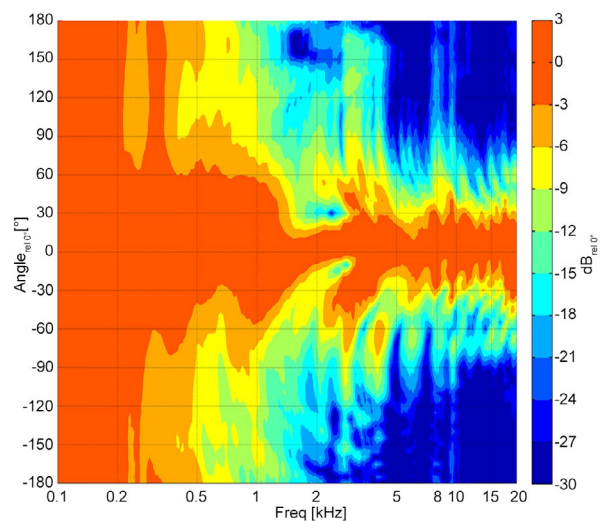

Figure A.4: Vertical directivity isobars

# 7 Appendix A: Specifications

## A.3 Venu 10 V2 Specifications

Frequency Response <sup>1</sup>	58 Hz - 20 kHz
Maximum Output <sup>2</sup>	122 dB cont, 128 dB peak
Nominal Dispersion	90°/40°H x 60°V rotatable
Sensitivity <sup>3</sup>	97 dB 1W/1m
Driver Configuration	1 x 10" LF, 1 x 1" HF compression driver
Power Handling	350 W AES
Nominal Impedance	8 $\Omega$
Suggested Minimum Amplifier	Bias Q1.5+
Weight	16 kg (35.3 lbs)
Connections	1 x Phoenix with link out 1 x 4-pin locking connector with link out
Enclosure	15 mm birch plywood
Finish	Textured polyurethane
Mounting	Yoke bracket 4 x M8 fixing points for Type 80 plate Optional 35mm top hat
Height	469 mm (18.5")
Width	301 mm (11.9")
Depth	260 mm (10.2")

<sup>1</sup> -10 dB IEC 60268-5 <sup>2</sup> Calculated <sup>3</sup> Measured in half space

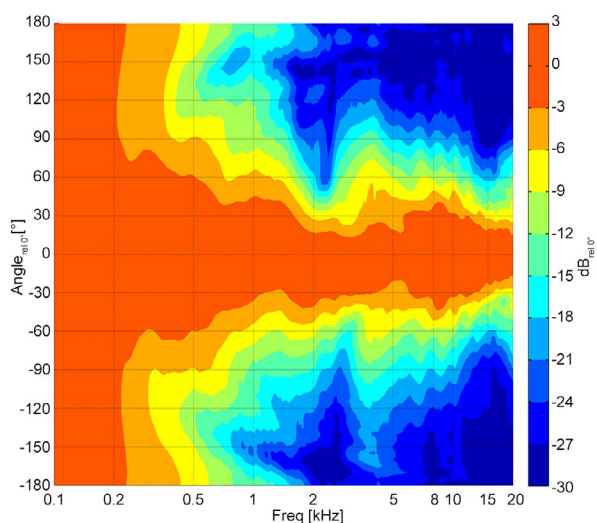

Figure A.5: Horizontal directivity isobars

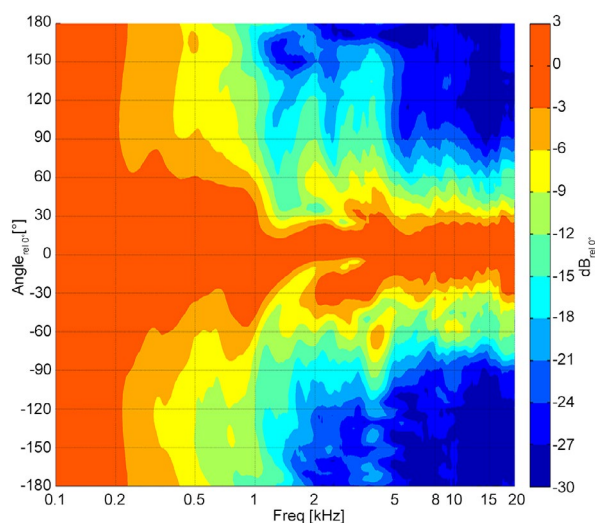

Figure A.6: Vertical directivity isobars

# 7 Appendix A: Specifications

## A.4 Venu 12 V2 Specifications

Frequency Response <sup>1</sup>	48 Hz - 20 kHz
Maximum Output <sup>2</sup>	124 dB cont, 130 dB peak
Nominal Dispersion	90°/40°H x 60°V rotatable
Sensitivity <sup>3</sup>	98 dB 1W/1m
Driver Configuration	1 x 12" LF, 1 x 1" HF compression driver
Power Handling	400 W AES
Nominal Impedance	8 $\Omega$
Suggested Minimum Amplifier	Bias Q1.5+
Weight	22 kg (48.5 lbs)
Connections	1 x Phoenix with link out 1 x 4-pin locking connector with link out
Enclosure	15 mm birch plywood
Finish	Textured polyurethane
Mounting	Yoke bracket 4 x M8 fixing points for type 80 plate Optional 35mm top hat
Height	522 mm (20.6")
Width	370 mm (14.6")
Depth	340 mm (13.4")

<sup>1</sup> -10 dB IEC 60268-5 <sup>2</sup> Calculated <sup>3</sup> Measured in half space

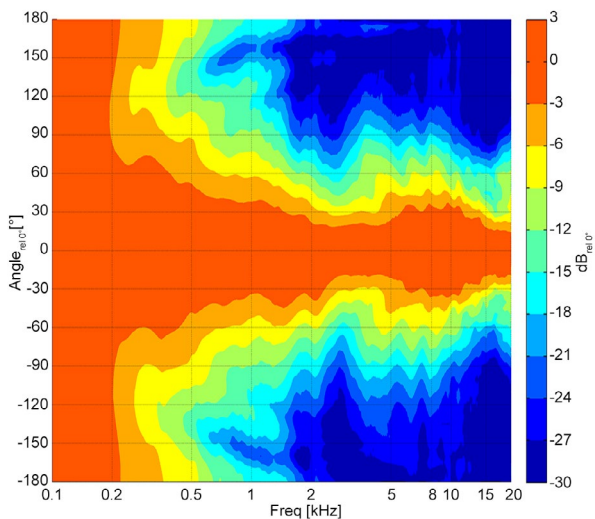

Figure A.7: Horizontal directivity isobars

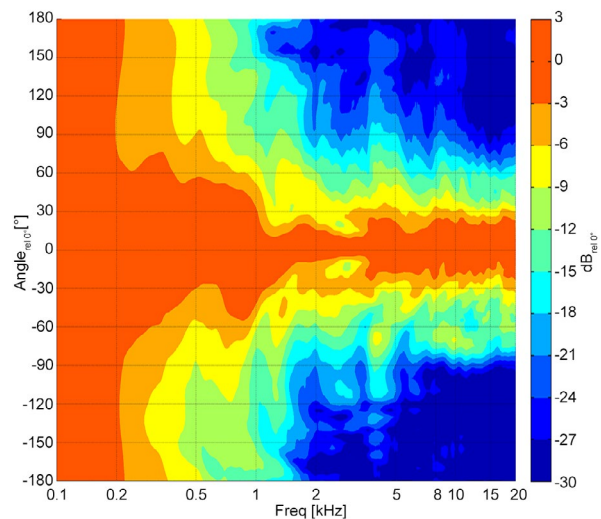

Figure A.8: Vertical directivity isobars

# 7 Appendix A: Specifications

## A.5 Venu 14 V2 Specifications

Frequency Response <sup>1</sup>	50 Hz - 20 kHz
Maximum Output <sup>2</sup>	124 dB cont, 130 dB peak
Nominal Dispersion	70° H x 50° V
Sensitivity <sup>3</sup>	99 dB 1W / 1M
Driver Configuration	1 x 13.5" LF, 1 x 1.4" HF coaxial compression driver
Power Handling	400 W AES
Nominal Impedance	8 $\Omega$
Suggested Minimum Amplifier	Bias Q1.5+
Weight	16.5 kg (36.4 lbs)
Connections	1 x Phoenix with link out and 1 x 4-pin locking connector with link out
Enclosure	15 mm birch plywood
Finish	Textured polyurethane
Mounting	Yoke bracket 4 x M8 fixing points for Type 80 plate. Optional 35mm top hat
Height	418.5mm (16.48in)
Width	257.2mm (10.12in)
Depth	378.1mm (14.89in)

<sup>1</sup> -10 dB IEC 60268-5 <sup>2</sup> Calculated <sup>3</sup> Measured in half space

# 7 Appendix A: Specifications

## A.6 Venu 15 V2 Specifications

Frequency Response <sup>1</sup>	46 Hz - 20 kHz
Maximum Output <sup>2</sup>	125 dB cont, 131 dB peak
Nominal Dispersion	90°/40°H x 60°V rotatable
Sensitivity <sup>3</sup>	99 dB 1W/1m
Driver Configuration	1 x 15" LF, 1 x 1" HF compression driver
Power Handling	450 W AES
Nominal Impedance	8 $\Omega$
Suggested Minimum Amplifier	Bias Q1.5+
Weight	31 kg (68.3 lbs)
Connections	1 x Phoenix with link out 1 x 4-pin locking connector with link out
Enclosure	15 mm birch plywood
Finish	Textured polyurethane
Mounting	Yoke bracket 4 x M8 fixing points for Type 80 plate Optional 35mm top hat
Height	670 mm (26.4")
Width	458 mm (18")
Depth	381 mm (15")

<sup>1</sup> -10 dB IEC 60268-5 <sup>2</sup> Calculated <sup>3</sup> Measured in half space

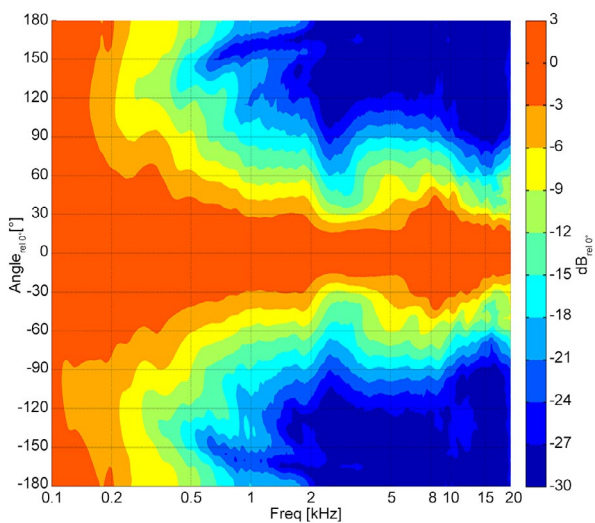

Figure A.11: Horizontal directivity isobars

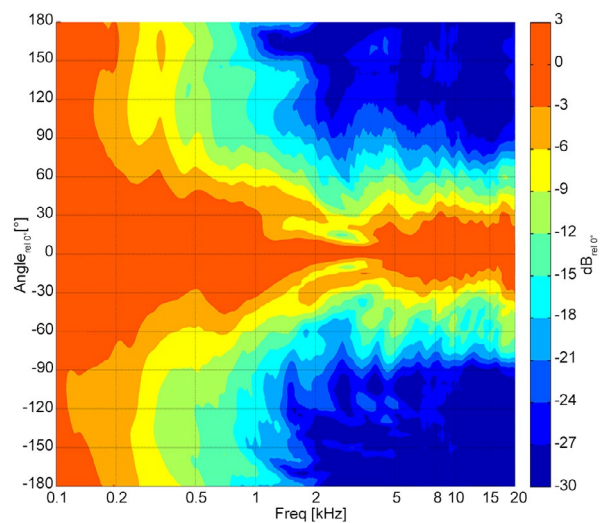

Figure A.12: Vertical directivity isobars

# 7 Appendix A: Specifications

## A.7 Venu 112 V2 Specifications

Frequency Response <sup>1</sup>	38 Hz - Preset dependent
Maximum Output <sup>2</sup>	126 dB cont, 132 dB peak
Nominal Dispersion	Array dependent
Sensitivity <sup>3</sup>	99 dB 1W/1m
Driver Configuration	1 x 12" LF
Power Handling	600 W AES
Nominal Impedance	8 $\Omega$
Suggested Minimum Amplifier	Bias Q1.5+
Weight	27 kg (59.5 lbs)
Connections	1 x Phoenix with link out 1 x 4-pin locking connector with link out
Enclosure	15 mm birch plywood
Finish	Textured polyurethane
Mounting	Yoke bracket 4 x M8 bolts for Type 75 plate Optional M20 top hat
Height	370 mm (14.6")
Width	490 mm (19.3")
Depth	430 mm (16.9")

<sup>1</sup> -10 dB IEC 60268-5 <sup>2</sup> Calculated <sup>3</sup> Measured in half space

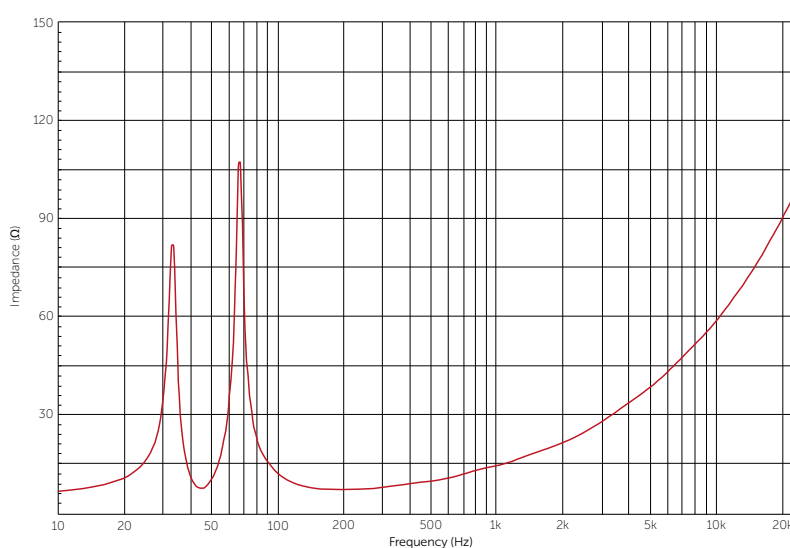

Figure A.13: Venu 112 V2 impedance graph

# 7 Appendix A: Specifications

## A.8 Venu 212 V2 Specifications

Frequency Response <sup>1</sup>	38 Hz - Preset dependent
Maximum Output <sup>2</sup>	129 dB cont, 135 dB peak
Nominal Dispersion	Array dependent
Sensitivity <sup>3</sup>	99 dB 1W/1m
Driver Configuration	2 x 12" LF
Power Handling	1200 W AES
Nominal Impedance	4 $\Omega$
Suggested Minimum Amplifier	Bias Q2+
Weight	47.5 kg (104.7 lbs)
Connections	1 x Phoenix with link out 1 x 4-pin locking connector with link out
Enclosure	15 mm birch plywood
Finish	Textured polyurethane
Mounting	Yoke bracket Optional M20 top hat
Height	370 mm (14.6")
Width	780 mm (30.7")
Depth	490 mm (19.3")

<sup>1</sup> -10 dB IEC 60268-5 <sup>2</sup> Calculated <sup>3</sup> Measured in half space

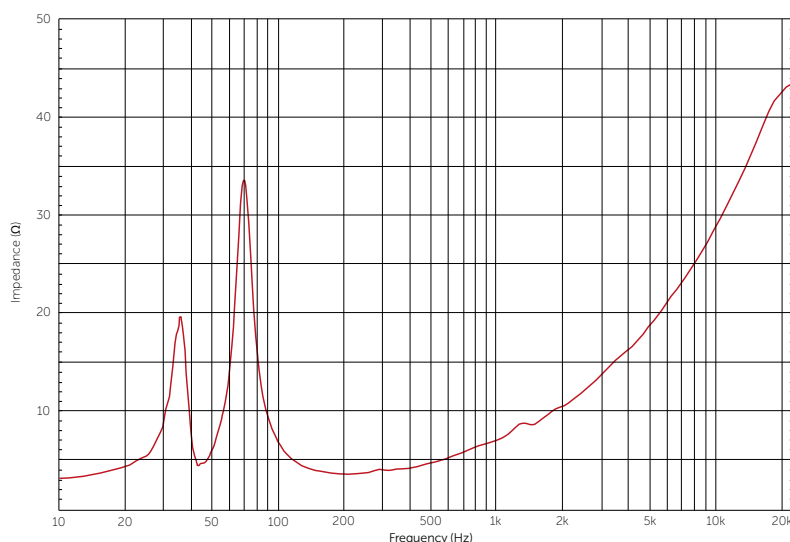

Figure A.14: Venu 212 V2 impedance graph

# 7 Appendix A: Specifications

## A.9 Venu 115 V2 Specifications

Frequency Response <sup>1</sup>	33 Hz - Preset dependent
Maximum Output <sup>2</sup>	123 dB cont, 129 dB peak
Nominal Dispersion	Array dependent
Sensitivity <sup>3</sup>	98 dB 1W/1m
Driver Configuration	1 x 15" LF
Power Handling	500 W AES
Nominal Impedance	8 $\Omega$
Suggested Minimum Amplifier	Bias Q1.5+
Weight	35 kg (77.2 lbs)
Connections	1 x Phoenix with link out 1 x 4-pin locking connector with link out
Enclosure	15 mm birch plywood
Finish	Textured polyurethane
Mounting	Yoke bracket 4 x M8 bolts for Type 75 plate Optional M20 top hat
Height	446 mm (17.6")
Width	448 mm (17.6")
Depth	636 mm (25")

<sup>1</sup> -10 dB IEC 60268-5 <sup>2</sup> Calculated <sup>3</sup> Measured in half space

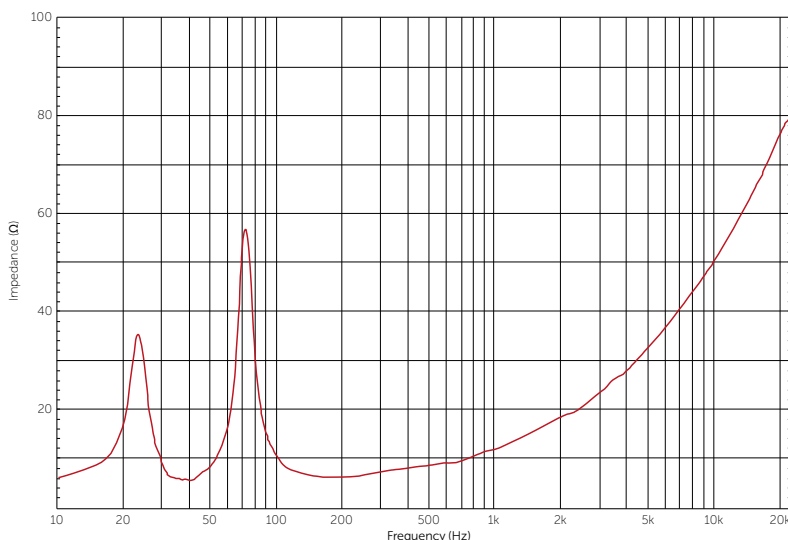

Figure A.15: Venu 115 V2 impedance graph

# 7 Appendix A: Specifications

## A.10 Venu 118 V2 Specifications

Frequency Response <sup>1</sup>	30 Hz - Preset dependent
Maximum Output <sup>2</sup>	126 dB cont. 132 dB peak
Nominal Dispersion	Array dependent
Sensitivity <sup>3</sup>	97 dB 1W/1m
Driver Configuration	1 x 18" LF
Power Handling	1200 W AES
Nominal Impedance	8 $\Omega$
Suggested Minimum Amplifier	Bias Q2+
Weight	42.48 kg (93.7 lbs)
Connections	1 x Phoenix with link out 1 x 4-pin locking connector with link out
Enclosure	18 mm birch plywood
Finish	Textured polyurethane
Mounting	Optional M20 top hat
Crossover Points	80 Hz - 160 Hz active
Height	557.5mm (21.95in)
Width	548.0mm (21.57in)
Depth	636.0mm (25.04in)

<sup>1</sup> -10 dB IEC 60268-5 <sup>2</sup> Calculated <sup>3</sup> Measured in half space

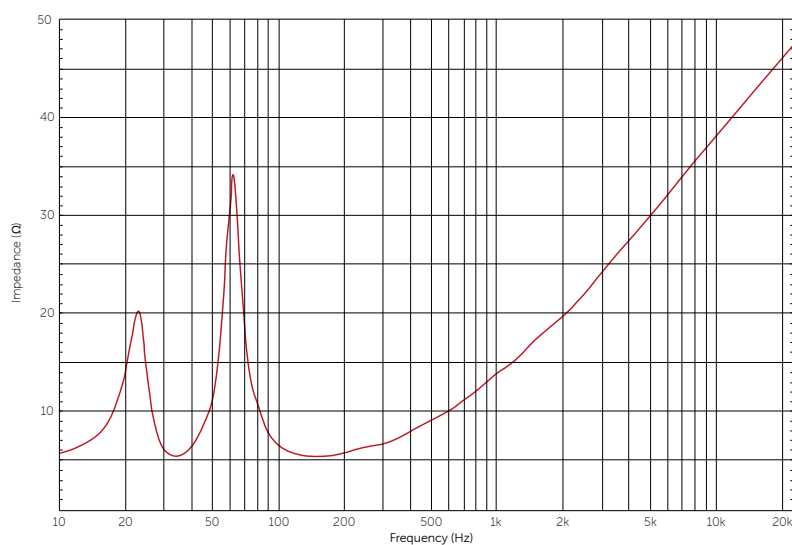

Figure A.16: Venu 118 V2 impedance graph

# 7 Appendix A: Specifications

## A.11 Venu 215 V2 Specifications

Frequency Response <sup>1</sup>	33 Hz - Preset dependent
Maximum Output <sup>2</sup>	130 dB cont, 136 dB peak
Nominal Dispersion	Array dependent
Sensitivity <sup>3</sup>	101 dB 1W/1m
Driver Configuration	2 x 15" LF
Power Handling	1000 W AES
Nominal Impedance	4 $\Omega$
Suggested Minimum Amplifier	Bias Q2+
Weight	62.5 kg (137.8 lbs)
Connections	1 x Phoenix with link out 1 x 4-pin locking connector with link out
Enclosure	15 mm birch plywood
Finish	Textured polyurethane
Mounting	Optional M20 top hat
Height	446 mm (17.6")
Width	860 mm (33.9")
Depth	636 mm (25")

<sup>1</sup> -10 dB IEC 60268-5 <sup>2</sup> Calculated <sup>3</sup> Measured in half space

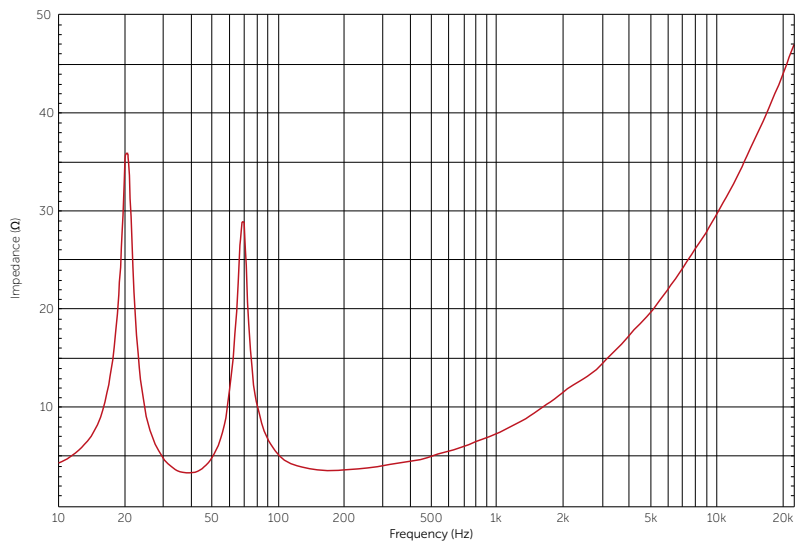

Figure A.17: Venu 215 impedance graph

# 7 Appendix A: Specifications

## A.12 Venu 218 V2 Specifications

Frequency Response <sup>1</sup>	30 Hz - Preset dependent
Maximum Output <sup>2</sup>	132 dB cont. 138 dB peak
Nominal Dispersion	Array dependent
Sensitivity <sup>3</sup>	100 dB 1W / 1M
Driver Configuration	2 x 18" LF
Power Handling	2400 W AES
Nominal Impedance	4 $\Omega$
Suggested Minimum Amplifier	Bias Q5
Weight	78.87 kg (173.9lbs)
Connections	1 x Phoenix with link out 1 x 4-pin locking connector with link out
Enclosure	18 mm birch plywood
Finish	Textured polyurethane
Mounting	Optional M20 top hat
Height	550.0mm (21.7in)
Width	1100.0mm (43.3in)
Depth	636.0mm (25.0in)

<sup>1</sup> -10 dB IEC 60268-5 <sup>2</sup> Calculated <sup>3</sup> Measured in half space

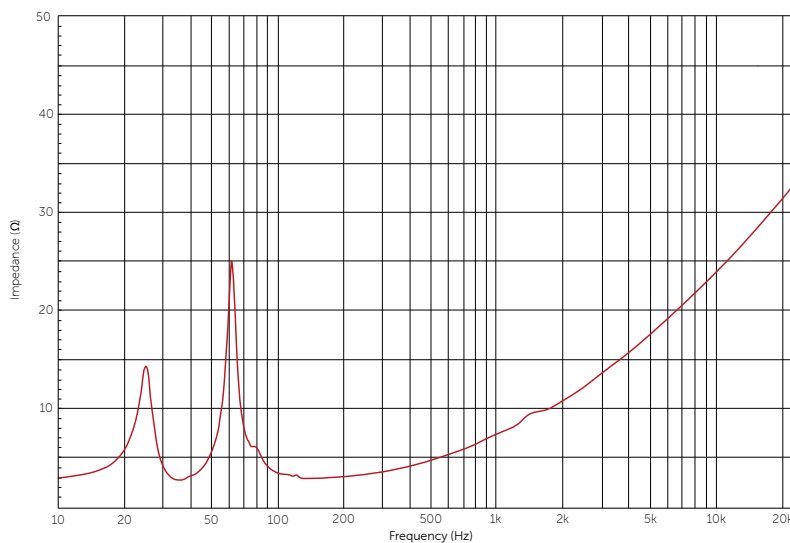

Figure A.18: Venu 218 impedance graph

# 7 Appendix A: Specifications

## A.13 Venu 208 V2 Specifications

Frequency Response <sup>1</sup>	38 Hz - Preset dependent
Maximum Output <sup>2</sup>	119 dB cont. 125 dB peak
Nominal Dispersion	Array dependent
Sensitivity <sup>3</sup>	95 dB 1W/1m
Driver Configuration	2 x 8" LF
Power Handling	300 W AES
Nominal Impedance	8 $\Omega$
Suggested Minimum Amplifier	Bias Q1+
Weight	20 kg (44.1 lbs)
Connections	1 x Phoenix with link out 1 x 4-pin locking connector with link out
Enclosure	15 mm birch plywood
Finish	Textured polyurethane
Mounting	Yoke bracket and Type 75 plate
Height	203 mm (8")
Width	600 mm (23.6")
Depth	475 mm (18.7")

<sup>1</sup> -10 dB IEC 60268-5 <sup>2</sup> Calculated <sup>3</sup> Measured in half space

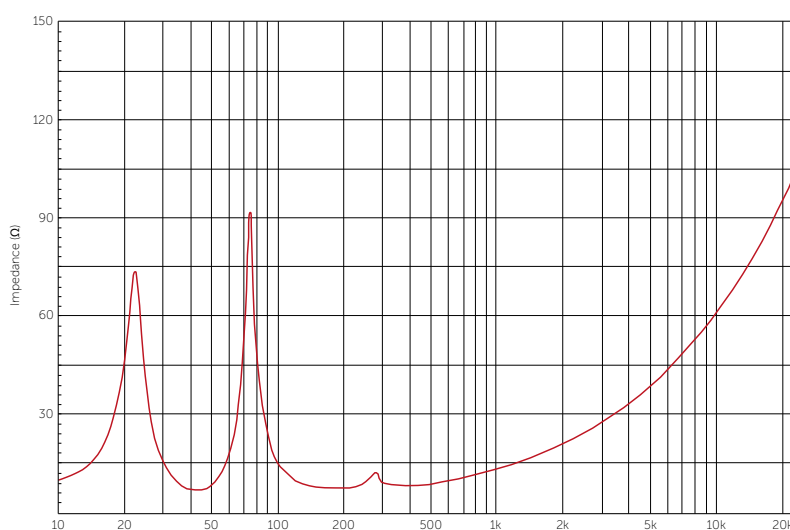

Figure A.19: Venu 208 impedance graph

# 8 Appendix B: Dimensions

## B.1 Venu 6 V2 Dimensions

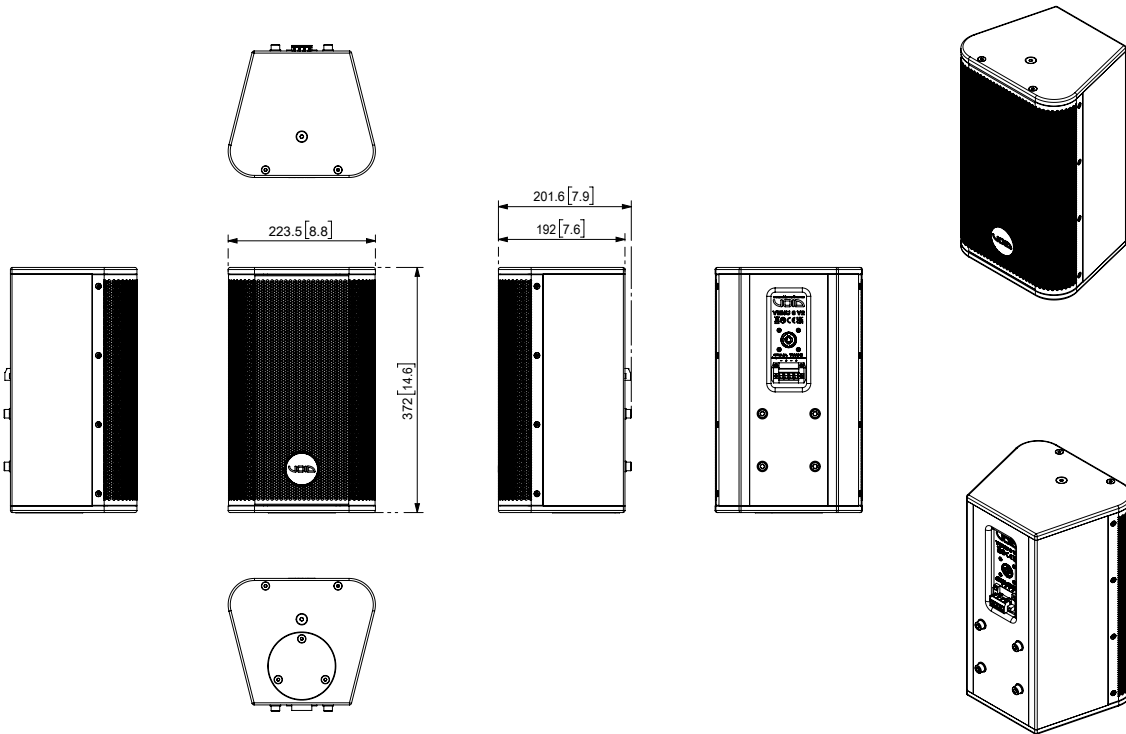

Figure B.1: Venu 6 V2 dimensions

## B.2 Venu 8 V2 Dimensions

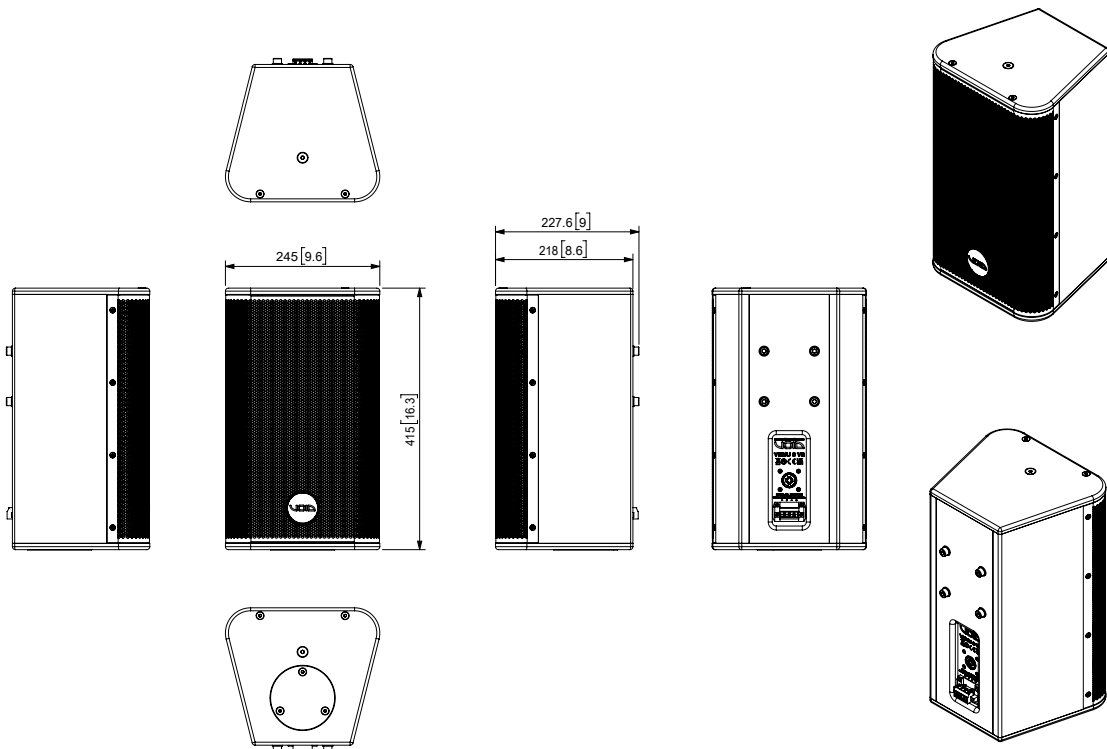

Figure B.2: Venu 8 V2 dimensions

# 8 Appendix B: Dimensions

## B.3 Venu 10 V2 Dimensions

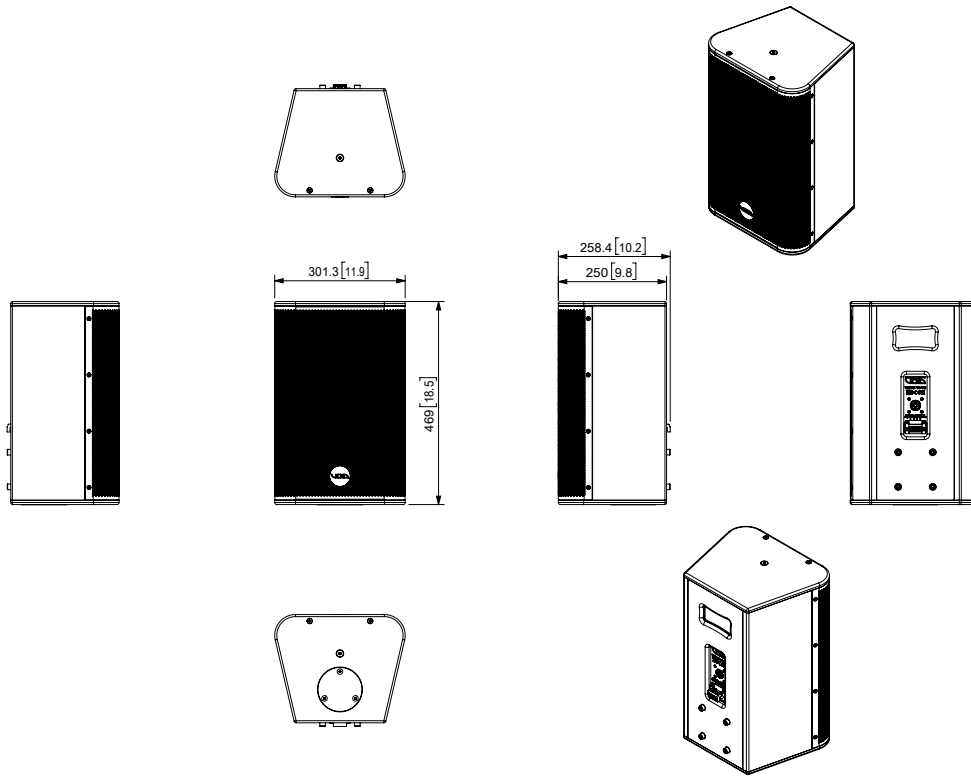

Figure B.3: Venu 10 V2 dimensions

## B.4 Venu 12 V2 Dimensions

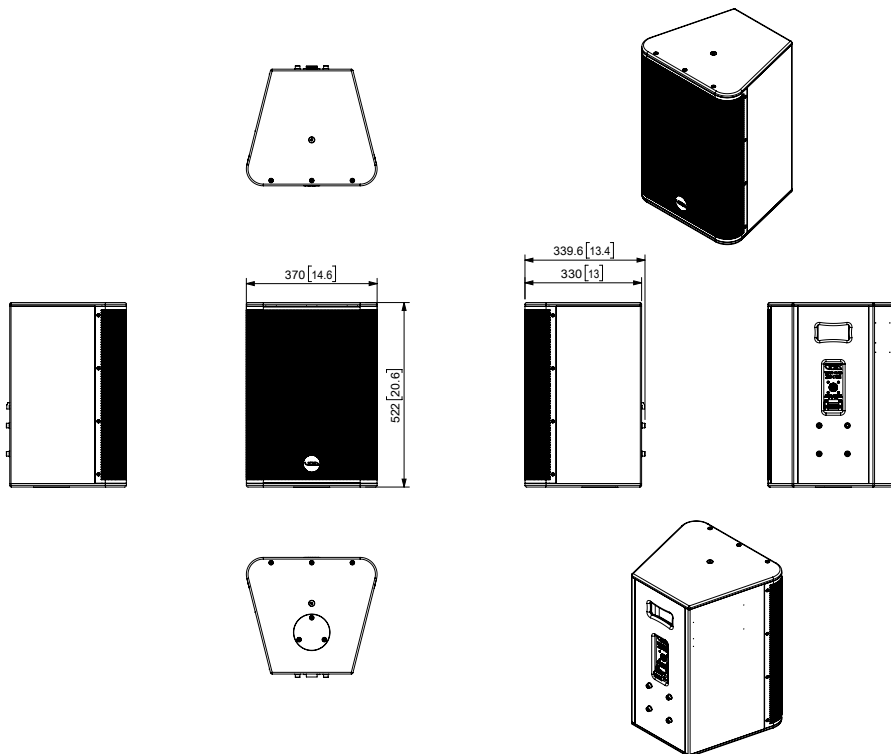

Figure B.4: Venu 12 V2 dimensions

# 8 Appendix B: Dimensions

## B.5 Venu 14 V2 Dimensions

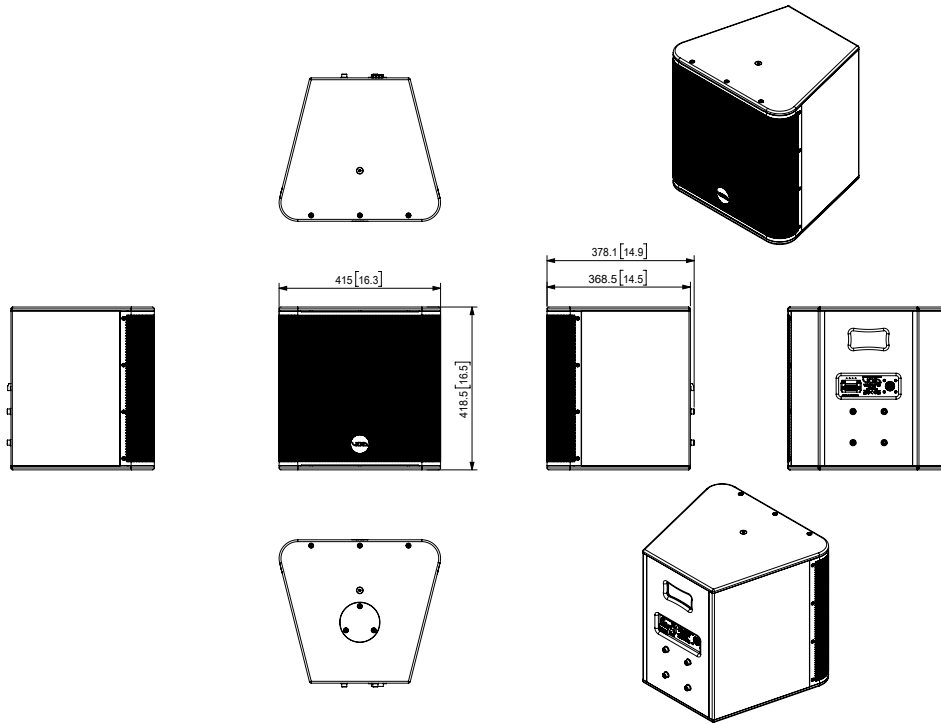

Figure B.5: Venu 14 V2 dimensions

## B.6 Venu 15 V2 Dimensions

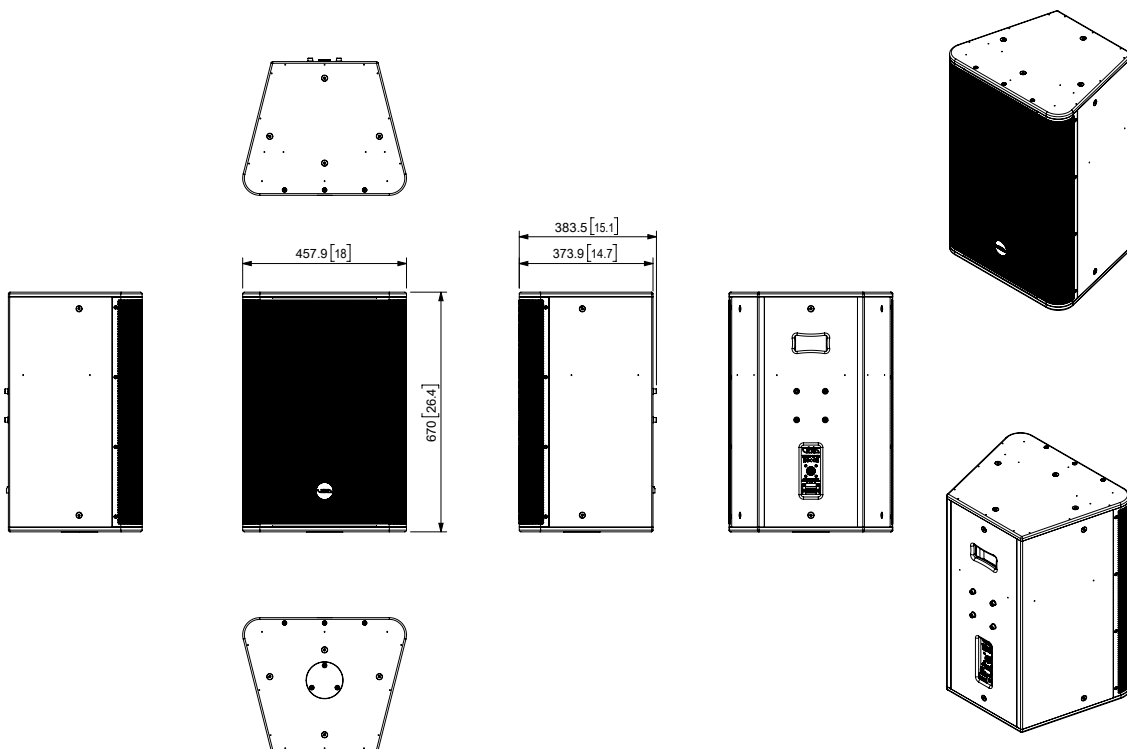

Figure B.6: Venu 15 V2 dimensions

# 8 Appendix B: Dimensions

## B.7 Venu 112 V2 Dimensions

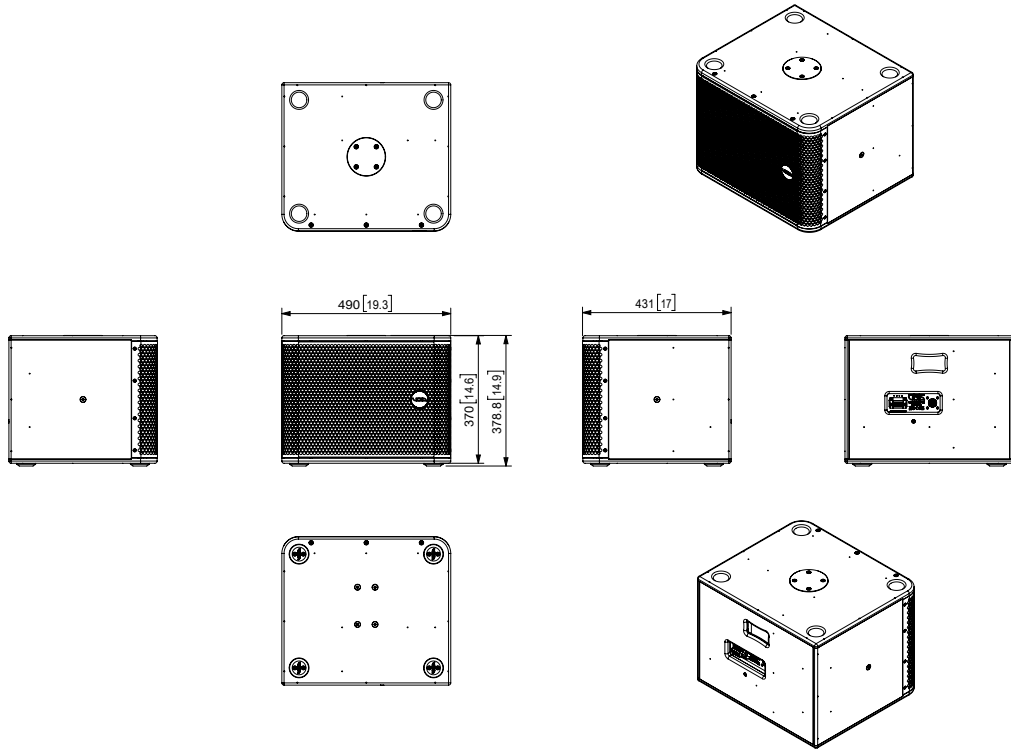

Figure B.7: Venu 112 V2 dimensions

## B.8 Venu 212 V2 Dimensions

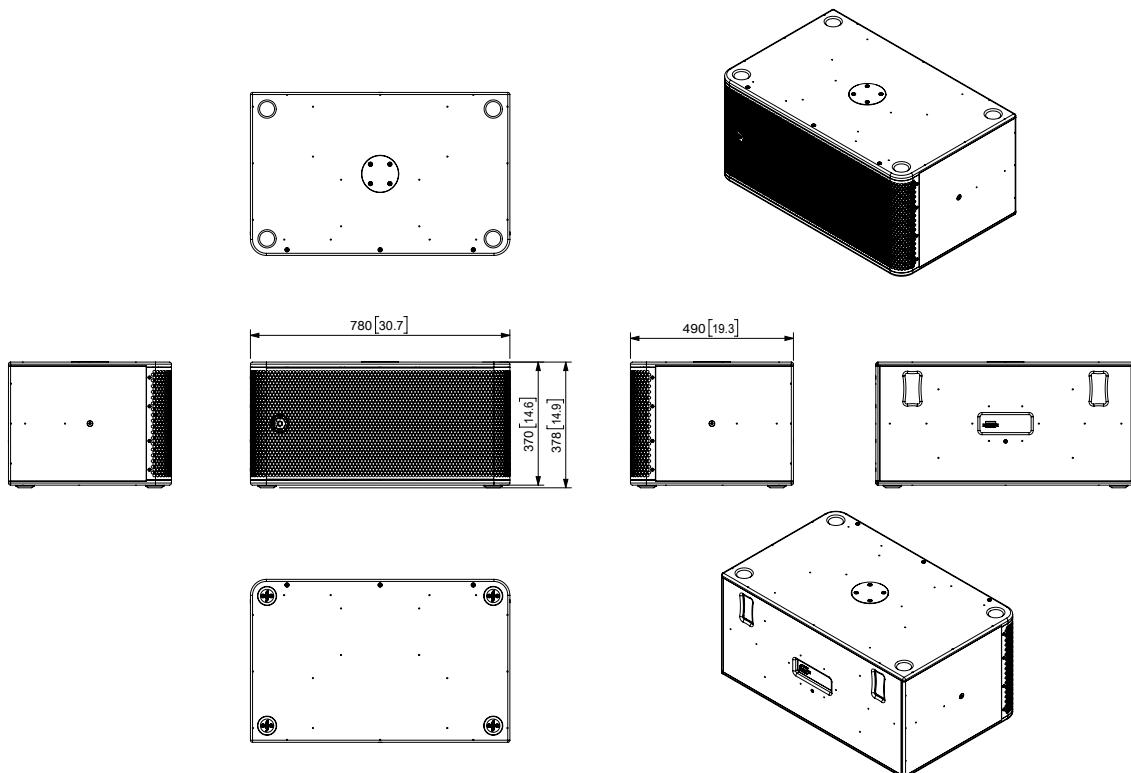

Figure B.8: Venu 212 V2 dimensions

# 8 Appendix B: Dimensions

## B.9 Venu 115 V2 Dimensions

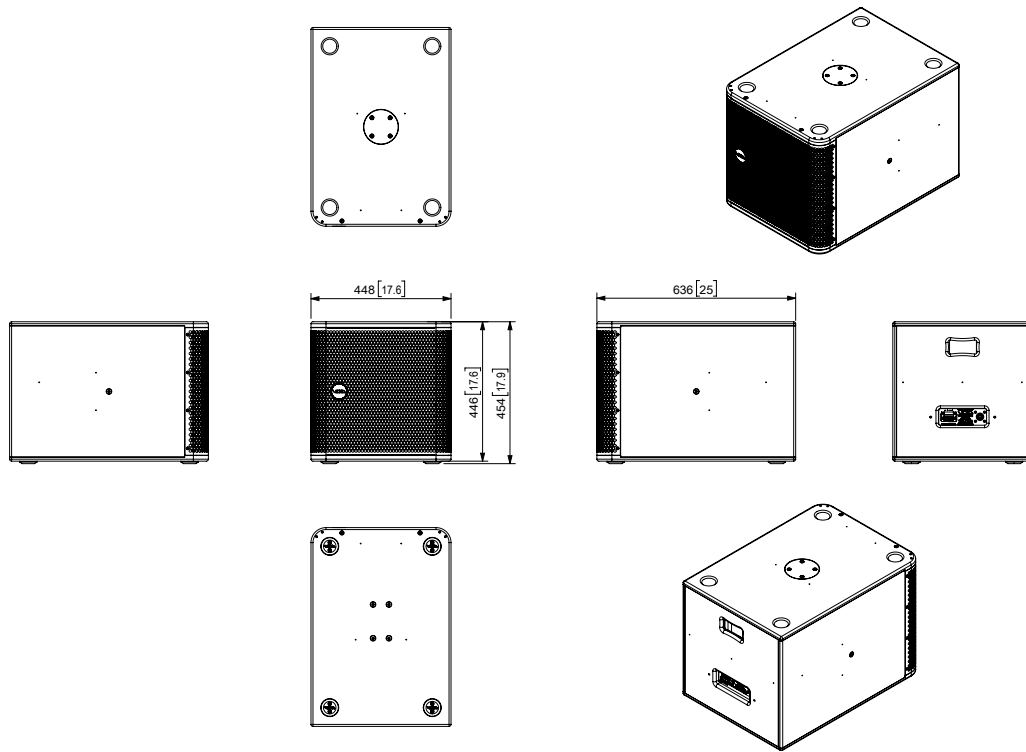

Figure B.9: Venu 115 V2 dimensions

## B.10 Venu 215 V2 Dimensions

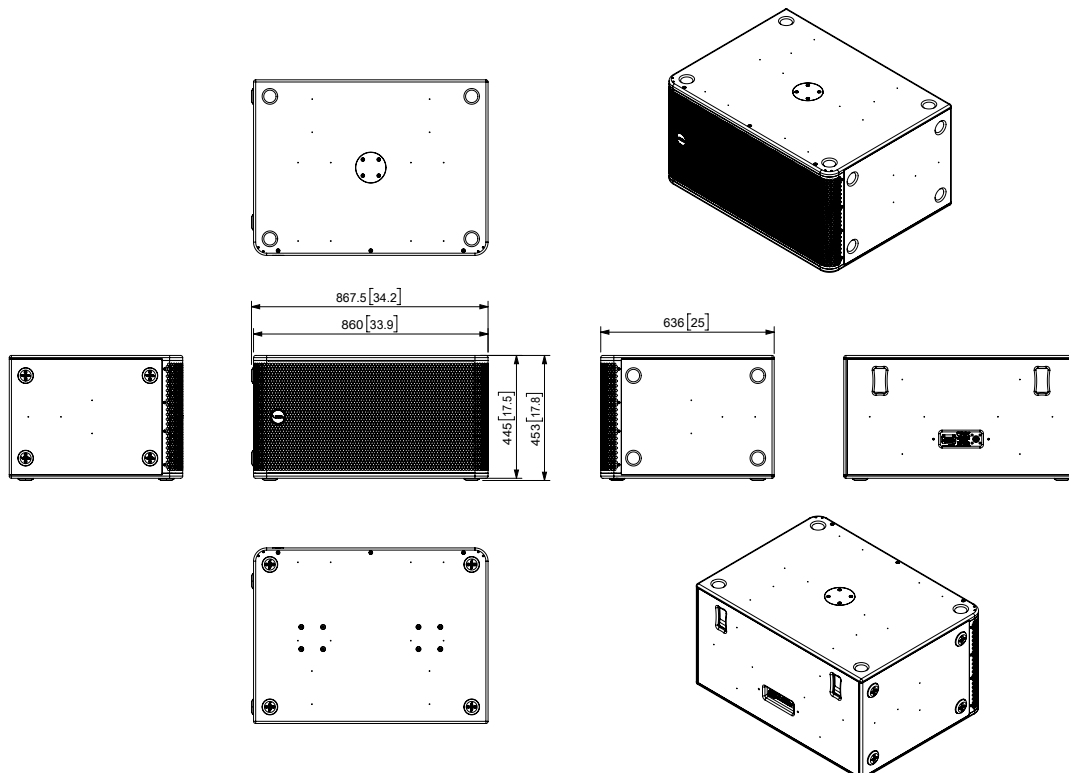

Figure B.10: Venu 215 V2 dimensions

# 8 Appendix B: Dimensions

## B.11 Venu 118 V2 Dimensions

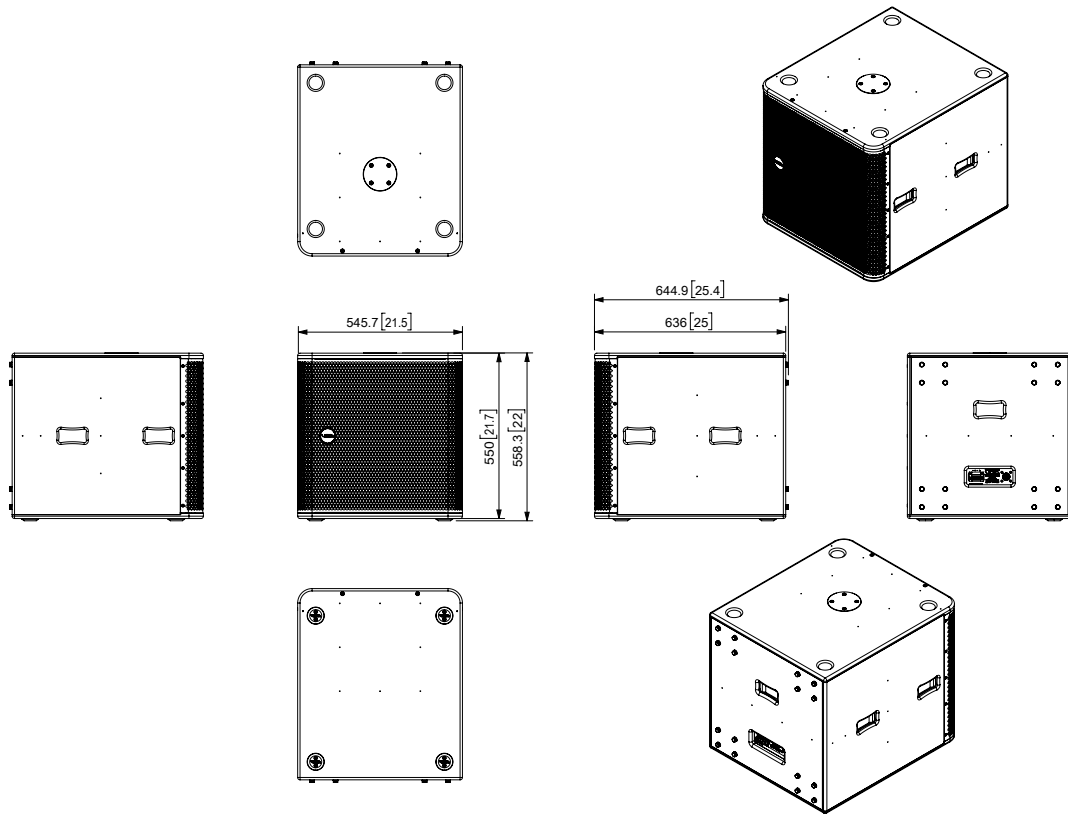

Figure B.11: Venu 118 V2 dimensions

## B.12 Venu 218 V2 Dimensions

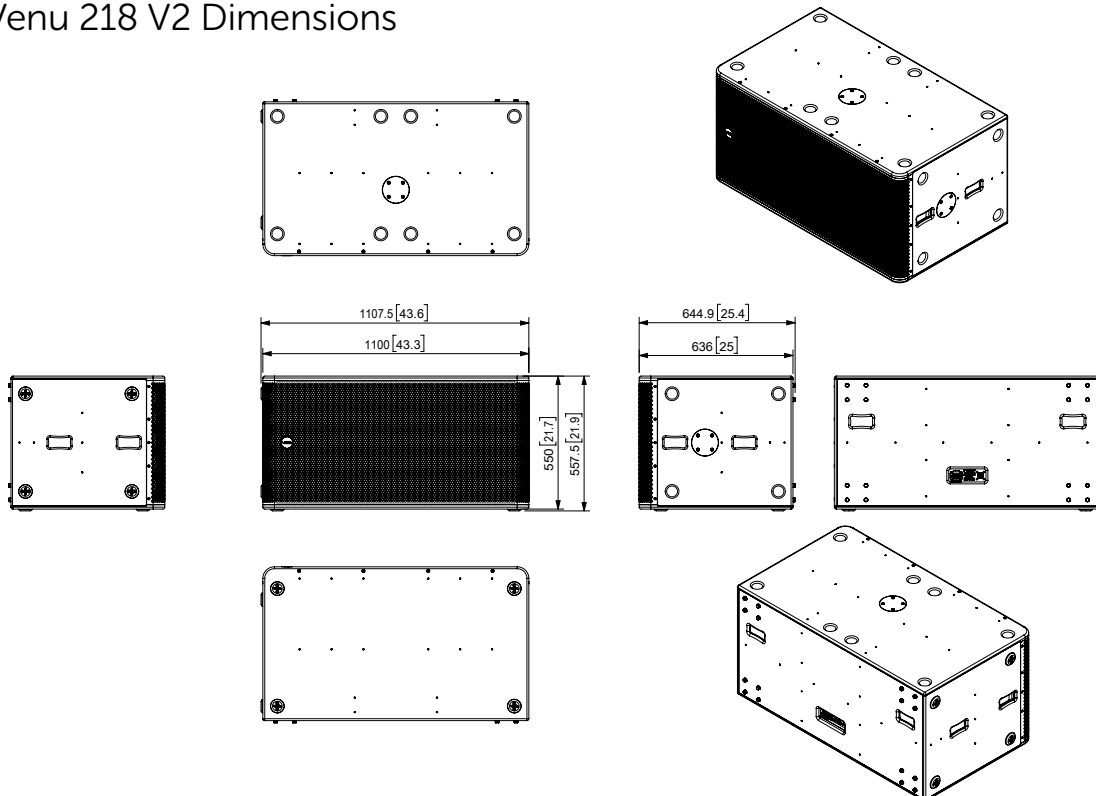

Figure B.12: Venu 218 V2 dimensions

# 8 Appendix B: Dimensions

## B.13 Venu 208 V2 Dimensions

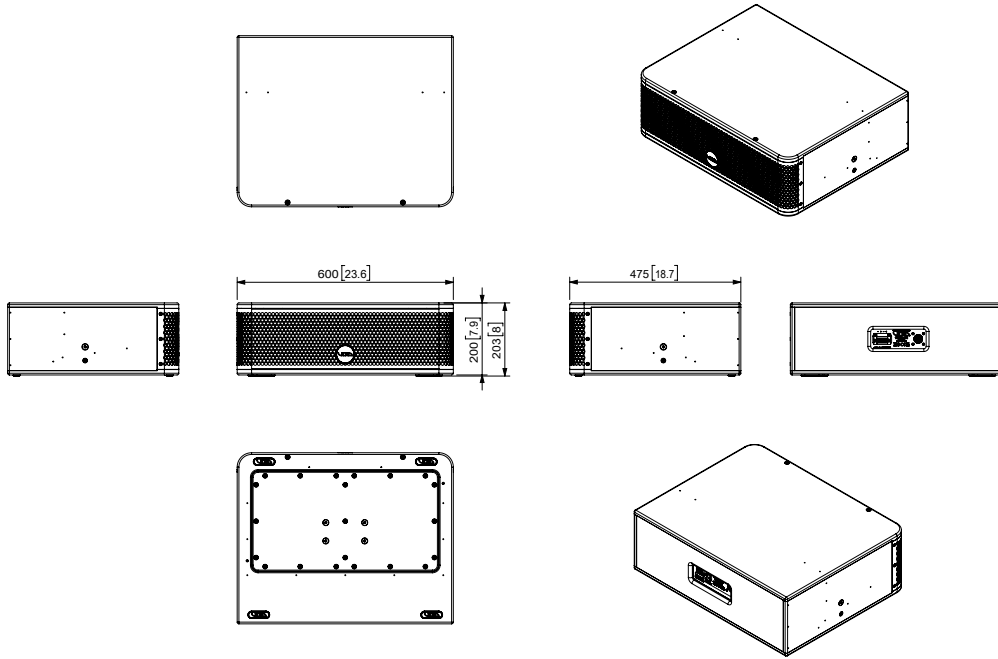

Figure B.13: Venu 208 V2 dimensions

# 9 Appendix C: Architectural Specifications

## Venu 6 V2 Architectural Specifications

The loudspeaker shall be a passive two-way system consisting of one high power 6.5" (165 mm), direct radiating, reflex loaded, low frequency (LF) transducer and 1" (25 mm) diameter composite plastic exit, high frequency (HF) compression driver mounted on a user rotatable elliptic horn in a trapezoidal enclosure fitted with a wrap around grille and rotatable badge.

Power handling shall be 200 W AES at a nominal impedance of 8  $\Omega$ . Crossover point shall be at 2.4 kHz using a 3rd order filter (18 dB per octave). The wiring connection shall be as follows: a removable, lockable wiring connector with four screw-down terminals (one pair for input and one pair for link through to another loudspeaker) to provide secure wiring and allow for pre-wiring of the connector before the installation (this connector should then screw lock to the enclosure for secure attachment). In addition, a 4-pin locking connector shall also feature.

Performance specifications for a typical production unit shall be as follows: the usable on-axis bandwidth shall be 68 Hz to 20 kHz (-10 dB IEC 60268-5) and shall average 90° directivity pattern on the horizontal axis and 60° on the vertical one (-6 dB down from on-axis level) from 1 kHz to 12 kHz; and a maximum SPL of 124 dB peak measured at 1 m using IEC268-5 pink noise.

The high frequency transducer shall project it's sound through an elliptic horn with a 152 mm (6") baffle diameter to achieve pattern control and low distortion. The low frequency transducer shall be constructed on a cast aluminium frame, with a treated paper cone, 38.1 mm (1.5") voice coil, wound with copper wires on a high quality Kapton voice coil former, for high power handling and long-term reliability.

The enclosure shall be of a trapezoidal shape constructed from a 15 mm multi-laminate birch plywood, with a textured polyurethane finish and shall include integral threaded inserts for the fitment of wall and ceiling mounting hardware as well as removable cover plate for fixing an optional M20 top-hat. External dimensions of (W) 224 mm x (H) 372 mm x (D) 202 mm (8.8" x 14.6" x 7.9"). Weight shall be 9.5 kg (20.9 lbs).

The loudspeaker shall be the Void Acoustics Venu 6 V2.

# 9 Appendix C: Architectural Specifications

## Venu 8 V2 Architectural Specifications

The loudspeaker shall be a passive two-way system consisting of one high power 8" (203.2 mm), direct radiating, reflex loaded, low frequency (LF) transducer and 1" (25 mm) diameter composite plastic exit, high frequency (HF) compression driver mounted on a user rotatable asymmetrical horn in a trapezoidal enclosure fitted with a wraparound grille and rotatable badge.

Power handling shall be 300 W AES at a nominal impedance of 8  $\Omega$ . Crossover point shall be at 2.3 kHz using a 3rd order filter (18 dB per octave). The wiring connection shall be as follows: a removable, lockable wiring connector with four screw-down terminals (one pair for input and one pair for link through to another loudspeaker) to provide secure wiring and allow for pre-wiring of the connector before the installation (this connector should then screw lock to the enclosure for secure attachment). In addition, a 4-pin locking connector shall also feature.

Performance specifications for a typical production unit shall be as follows: the usable on-axis bandwidth shall be 63 Hz to 20 kHz (-10 dB IEC 60268-5) and shall average 90° to 40° directivity pattern on the horizontal axis and 60° on the vertical one (-6 dB down from on-axis level) from 1 kHz to 12 kHz; and a maximum SPL of 127 dB peak measured at 1 m using IEC268-5 pink noise.

The high frequency transducer shall project it's sound through an asymmetrical horn with a 152 mm (6") baffle diameter to achieve pattern control and low distortion. The low frequency transducer shall be constructed on a cast aluminium frame, with a treated paper cone, 50.8 mm (2") voice coil, wound with copper wires on a high quality Kapton voice coil former, for high power handling and long-term reliability.

The enclosure shall be of a trapezoidal shape constructed from a 15 mm multi-laminate birch plywood, with a textured polyurethane finish and shall include integral threaded inserts for the fitment of wall and ceiling mounting hardware as well as removable cover plate for fixing an optional M20 top-hat. External dimensions of (W) 245 mm x (H) 415 mm x (D) 228 mm (9.6" x 16.3" x 9"). Weight shall be 12 kg (26.5 lbs).

The loudspeaker shall be the Void Acoustics Venu 8 V2.

# 9 Appendix C: Architectural Specifications

## Venu 10 V2 Architectural Specifications

The loudspeaker shall be a passive two-way system consisting of one high power 10" (250 mm), direct radiating, reflex loaded, low frequency (LF) transducer and 1" (25 mm) diameter composite plastic exit, high frequency (HF) compression driver mounted on a user rotatable asymmetrical horn in a trapezoidal enclosure fitted with a wraparound grille and rotatable badge.

Power handling shall be 350 W AES at a nominal impedance of 8  $\Omega$ . Crossover point shall be at 2.1 kHz using a 3rd order filter (18 dB per octave). The wiring connection shall be as follows: a removable, lockable wiring connector with four screw-down terminals (one pair for input and one pair for link through to another loudspeaker) to provide secure wiring and allow for pre-wiring of the connector before the installation (this connector should then screw lock to the enclosure for secure attachment). In addition, a 4-pin locking connector shall also feature.

Performance specifications for a typical production unit shall be as follows: the usable on-axis bandwidth shall be 58 Hz to 20 kHz (-10 dB IEC 60268-5) and shall average 90° to 40° directivity pattern on the horizontal axis and 60° on the vertical one (-6 dB down from on-axis level) from 1 kHz to 12 kHz; and a maximum SPL of 128 dB peak measured at 1 m using IEC268-5 pink noise.

The high frequency transducer shall project it's sound through an asymmetrical horn with a 152 mm (6") baffle diameter to achieve pattern control and low distortion. The low frequency transducer shall be constructed on a cast aluminium frame, with a treated paper cone, 50.8 mm (2") voice coil, wound with copper wires on a high quality Kapton voice coil former, for high power handling and long-term reliability.

The enclosure shall be of a trapezoidal shape constructed from a 15 mm multi-laminate birch plywood, with a textured polyurethane finish and shall include integral threaded inserts for the fitment of wall and ceiling mounting hardware as well as removable cover plate for fixing an optional M20 top-hat. External dimensions of (W) 301 mm x (H) 469 mm x (D) 260 mm (11.9" x 18.5" x 10.2"). Weight shall be 16 kg (35.3 lbs).

The loudspeaker shall be the Void Acoustics Venu 10 V2.

# 9 Appendix C: Architectural Specifications

## Venu 12 V2 Architectural Specifications

The loudspeaker shall be a passive two-way system consisting of one high power 12" (304.8 mm), direct radiating, reflex loaded, low frequency (LF) transducer and 1" (25 mm) diameter composite plastic exit, high frequency (HF) compression driver mounted on a user rotatable asymmetrical horn in a trapezoidal enclosure fitted with a wrap around grille and rotatable badge.

Power handling shall be 400 W AES at a nominal impedance of 8  $\Omega$ . Crossover point shall be at 2.1 kHz using a 3rd order filter (18 dB per octave). The wiring connection shall be as follows: a removable, lockable wiring connector with four screw-down terminals (one pair for input and one pair for link through to another loudspeaker) to provide secure wiring and allow for pre-wiring of the connector before the installation (this connector should then screw lock to the enclosure for secure attachment). In addition, a 4-pin locking connector shall also feature.

Performance specifications for a typical production unit shall be as follows: the usable on-axis bandwidth shall be 48 Hz to 20 kHz (-10 dB IEC 60268-5) and shall average 90° to 40° directivity pattern on the horizontal axis and 60° on the vertical one (-6 dB down from on-axis level) from 1 kHz to 12 kHz; and a maximum SPL of 130 dB peak measured at 1 m using IEC268-5 pink noise.

The high frequency transducer shall project it's sound through an asymmetrical horn with a 152 mm (6") baffle diameter to achieve pattern control and low distortion. The low frequency transducer shall be constructed on a cast aluminium frame, with a treated paper cone, 50.8 mm (2") voice coil, wound with copper wires on a high quality Kapton voice coil former, for high power handling and long-term reliability.

The enclosure shall be of a trapezoidal shape constructed from a 15 mm multi-laminate birch plywood, with a textured polyurethane finish and shall include integral threaded inserts for the fitment of wall and ceiling mounting hardware as well as removable cover plate for fixing an optional M20 top-hat. External dimensions of (W) 370 mm x (H) 522 mm x (D) 340 mm (14.6" x 20.6" x 13.4"). Weight shall be 22 kg (48.5 lbs).

The loudspeaker shall be the Void Acoustics Venu 12 V2.

# 9 Appendix C: Architectural Specifications

## Venu 14 V2 Architectural Specifications

The loudspeaker shall be a passive two-way system Preliminary Data consisting of one 13.5" (340 mm) direct radiating, reflex loaded, low frequency (LF) transducer and one 1.4" (36 mm) co-axially mounted high frequency (HF) compression transducer mounted on an asymmetrical waveguide in a trapezoidal enclosure fitted with a wraparound grille and rotatable badge.

Power handling shall be 400 W AES at a nominal impedance of 8  $\Omega$ . The wiring connection shall be as follows: a removable, lockable Phoenix connector with four screw-down terminals (one pair for input and one pair for link through to another loudspeaker) to provide secure wiring and allow for pre-wiring of the connector before the installation (this connector should then screw lock to the enclosure for secure attachment). In addition, a 4-pin locking connector shall also feature.

Performance specifications for a typical production unit shall be as follows: the usable on-axis bandwidth shall be 50 Hz – 20 kHz (-10 dB IEC 60268-5) and shall average 70° x 40° directivity pattern (-6 dB down from on-axis level) from 1 kHz to 10 kHz; **and a maximum SPL of 130 dB peak measured at 1 m using IEC268-5 pink noise.**

The high frequency transducer shall project it's sound through an asymmetrical waveguide to achieve pattern control and low distortion. The low frequency transducer shall be constructed on a resonant free and aluminium basket design with a 3" (76.2 mm) voice coil, wound with copper wire on a high-quality former for high power handling and long-term reliability.

The enclosure shall be of a trapezoidal shape constructed from 15 mm multi-laminated birch plywood, with a textured polyurethane finish, shall include M8 yoke mounting points and integral thread inserts for the fitment of wall and ceiling mounting hardware as well as removable cover plate for fixing an optional top hat. External dimensions of (W) 415 mm x (H) 418.5 mm x (D) 368.5 mm (16.34" x 16.48" x 14.51") and weigh 16.5 kg (36.4 lbs).

The loudspeaker system shall be a Void Acoustics Venu 14 V2.

# 9 Appendix C: Architectural Specifications

## Venu 15 V2 Architectural Specifications

The loudspeaker shall be a passive two-way system consisting of one high power 15" (381 mm), direct radiating, reflex loaded, low frequency (LF) transducer and 1" (25 mm) diameter composite plastic exit, high frequency (HF) compression driver mounted on a user rotatable asymmetrical horn in a trapezoidal enclosure fitted with a wraparound grille and rotatable badge.

Power handling shall be 450 W AES at a nominal impedance of 8  $\Omega$ . Crossover point shall be at 2.1 kHz using a 3rd order filter (18 dB per octave). The wiring connection shall be as follows: a removable, lockable wiring connector with four screw-down terminals (one pair for input and one pair for link through to another loudspeaker) to provide secure wiring and allow for pre-wiring of the connector before the installation (this connector should then screw lock to the enclosure for secure attachment). In addition, a 4-pin locking connector shall also feature.

Performance specifications for a typical production unit shall be as follows: the usable on-axis bandwidth shall be 46 Hz to 20 kHz (-10 dB IEC 60268-5) and shall average 90° to 40° directivity pattern on the horizontal axis and 60° on the vertical one (-6 dB down from on-axis level) from 1 kHz to 12 kHz; and a maximum SPL of 131 dB peak measured at 1 m using IEC268-5 pink noise.

The high frequency transducer shall project it's sound through an asymmetrical horn with a 152 mm (6") baffle diameter to achieve pattern control and low distortion. The low frequency transducer shall be constructed on a cast aluminium frame, with a treated paper cone, 75.5 mm (3") voice coil, wound with copper wires on a high quality Kapton voice coil former, for high power handling and long-term reliability.

The enclosure shall be of a trapezoidal shape constructed from a 15 mm multi-laminate birch plywood, with a textured polyurethane finish and shall include integral threaded inserts for the fitment of wall and ceiling mounting hardware as well as removable cover plate for fixing an optional M20 top-hat. External dimensions of (W) 458 mm x (H) 670 mm x (D) 381 mm (18" x 26.4" x 15"). Weight shall be 31 kg (68.3 lbs).

The loudspeaker shall be the Void Acoustics Venu 15 V2.

# 9 Appendix C: Architectural Specifications

## Venu 112 V2 Architectural Specifications

The loudspeaker shall be comprised of one high power 12" (304.8 mm) direct radiating, reflex loaded low frequency (LF) transducer. The enclosure shall be rectangular constructed from 15 mm multi-laminated birch plywood with a single handle in the rear with a wraparound grille and a rotating badge; it shall have a removable cover plate for fixing an optional M20 top hat and integral threaded inserts for the fitment of wall and ceiling mounting hardware; it shall be finished in a textured polyurethane with external dimensions of (H) 378 mm x (W) 490 mm x (D) 430 mm (14.9" x 19.3" x 16.9") and weigh 27 kg (59.5 lbs).

The wiring connection shall be as follows: a removable, lockable wiring connector with four screw-down terminals (one pair for input and one pair for link through to another loudspeaker) to provide secure wiring and allow for pre-wiring of the connector before the installation (this connector should then screw lock to the enclosure for secure attachment). In addition, a 4-pin locking connector shall also feature.

Performance specifications of a typical production unit shall be as follows: frequency response of 38 Hz – Preset dependent (-10 dB IEC 60268-5); 600 W long-term program per voice coil using EIA RS-426A pink noise (6 dB crest factor); pressure sensitivity of 99 dB at one Watt at one metre; rated nominal impedance of 8  $\Omega$ .

The low frequency transducer shall be constructed on a cast aluminium frame with a treated paper cone, 101.6 mm (4") voice, wound with copper wire on a high-quality voice coil former for high power handling and long-term reliability.

The loudspeaker system shall be a Void Acoustics Venu 112 V2.

# 9 Appendix C: Architectural Specifications

## Venu 212 V2 Architectural Specifications

The loudspeaker shall be comprised of two high power 12" (304.8 mm) direct radiating, reflex loaded low frequency (LF) transducers.

The enclosure shall be rectangular constructed from 15 mm multi-laminated birch plywood with two handles in the rear with a wraparound grille and a rotating badge; it shall have a removable cover plate for fixing an optional M20 top hat and integral threaded inserts for the fitment of wall and ceiling mounting hardware; it shall be finished in a textured polyurethane with external dimensions of (H) 370 mm x (W) 780 mm x (D) 490 mm (14.6" x 30.7" x 19.3") and weigh 47.5 kg (104.7 lbs).

The wiring connection shall be as follows: a removable, lockable wiring connector with four screw-down terminals (one pair for input and one pair for link through to another loudspeaker) to provide secure wiring and allow for pre-wiring of the connector before the installation (this connector should then screw lock to the enclosure for secure attachment). In addition, a 4-pin locking connector shall also feature.

Performance specifications of a typical production unit shall be as follows: frequency response of 38 Hz – Preset dependent (-10 dB IEC 60268-5); 1200 W long-term program per voice coil using EIA RS-426A pink noise (6 dB crest factor); pressure sensitivity of 99 dB at one Watt at one metre; rated nominal impedance of 4  $\Omega$ .

The low frequency transducer shall be constructed on a cast aluminium frame with a treated paper cone, 101.6 mm (4") voice, wound with copper wire on a high-quality voice coil former for high power handling and long-term reliability.

The loudspeaker system shall be a Void Acoustics Venu 212 V2.

# 9 Appendix C: Architectural Specifications

## Venu 115 V2 Architectural Specifications

The loudspeaker shall be comprised of one high power 15" (304.8 mm) direct radiating, reflex loaded low frequency (LF) transducer. The enclosure shall be rectangular constructed from 18 mm multi-laminated birch plywood with a single handle in the rear with a wraparound grille and a rotating badge; it shall have a removable cover plate for fixing an optional M20 top hat and integral threaded inserts for the fitment of wall and ceiling mounting hardware; it shall be finished in a textured polyurethane with external dimensions of (H) 454 mm x (W) 448 mm x (D) 636 mm (17.9" x 17.6" x 25") and weigh 35 kg (77.2 lbs).

The wiring connection shall be as follows: a removable, lockable wiring connector with four screw-down terminals (one pair for input and one pair for link through to another loudspeaker) to provide secure wiring and allow for pre-wiring of the connector before the installation (this connector should then screw lock to the enclosure for secure attachment). In addition, a 4-pin locking connector shall also feature.

Performance specifications of a typical production unit shall be as follows: frequency response of 33 Hz – Preset dependent (-10 dB IEC 60268-5); 500 W long-term program per voice coil using EIA RS-426A pink noise (6 dB crest factor); pressure sensitivity of 98 dB at one Watt at one metre; rated nominal impedance of 8  $\Omega$ .

The low frequency transducer shall be constructed on a cast aluminium frame with a treated paper cone, 101.6 mm (4") voice, wound with copper wire on a high-quality voice coil former for high power handling and long-term reliability.

The loudspeaker system shall be a Void Acoustics Venu 115 V2.

# 9 Appendix C: Architectural Specifications

## Venu 215 V2 Architectural Specifications

The loudspeaker shall be comprised of two high power 15" (304.8 mm) direct radiating, reflex loaded low frequency (LF) transducers. The enclosure shall be rectangular constructed from 15 mm multi-laminated birch plywood with two handles in the rear with a wraparound grille and a rotating badge; it shall have a removable cover plate for fixing an optional M20 top hat and shall be finished in a textured polyurethane with external dimensions of (H) 454 mm x (W) 868 mm x (D) 636 mm (17.9" x 34.2" x 25") and weigh 62.5 kg (137.8 lbs).

Performance specifications of a typical production unit shall be as follows: frequency response of 33 Hz – Preset dependent (-10 dB IEC 60268-5); 1000 W long-term program per voice coil using EIA RS-426A pink noise (6 dB crest factor); pressure sensitivity of 101 dB at one Watt at one metre; rated nominal impedance of 4  $\Omega$ .

The low frequency transducer shall be constructed on a cast aluminium frame with a treated paper cone, 101.6 mm (4") voice, wound with copper wire on a high-quality voice coil former for high power handling and long-term reliability.

The wiring connection shall be as follows: a removable, lockable wiring connector with four screw-down terminals (one pair for input and one pair for link through to another loudspeaker) to provide secure wiring and allow for pre-wiring of the connector before the installation (this connector should then screw lock to the enclosure for secure attachment). In addition, a 4-pin locking connector shall also feature.

The loudspeaker system shall be a Void Acoustics Venu 215 V2.

# 9 Appendix C: Architectural Specifications

## Venu 118 V2 Architectural Specifications

The loudspeaker shall be comprised of a single 18" (457.2mm) direct radiating, reflex loaded, low frequency (LF) transducer in a birch plywood enclosure.

The enclosure shall be constructed from 18 mm multi-laminated birch plywood with handles on the side and the rear, a wraparound grille, and a rotating badge; it shall have a removable cover plate for fixing an optional M20 top hat and shall be finished in a textured polyurethane with external dimensions of (H) 557 mm x (W) 548 mm x (D) 636 mm (21.9" x 21.6" x 25"). Weight is 42.48 kg (93.7 lbs).

Performance specifications of a typical production unit shall be as follows: frequency response of 30 Hz – Preset dependent (-10 dB IEC 60268-5); 1200 W long-term program per voice coil using EIA RS-426A pink noise (6 dB crest factor); pressure sensitivity of 97 dB at one Watt 100 Hz – 10 kHz at one metre; rated nominal impedance of 8  $\Omega$ .

The low frequency transducer shall be constructed on a resonant free and heavy-duty basket design with a 4" (101.6mm) voice coil, wound with copper wire on a high-quality former for high power handling and long-term reliability.

The wiring connection shall be as follows: a removable, lockable Phoenix connector with four screw-down terminals (one pair for input and one pair for link through to another loudspeaker) to provide secure wiring and allow for pre-wiring of the connector before the installation (this connector should then screw lock to the enclosure for secure attachment). In addition, a 4-pin locking connector shall also feature.

The loudspeaker system shall be a Void Acoustics Venu 118 V2.

# 9 Appendix C: Architectural Specifications

## Venu 218 V2 Architectural Specifications

The loudspeaker shall be comprised of two 18" (457.2mm) direct radiating, reflex loaded, low frequency (LF) transducers in a birch plywood enclosure.

The enclosure shall be constructed from 18 mm multi-laminated birch plywood with handles on the side and the rear, a wraparound grille, and a rotating badge; it shall have a removable cover plate for fixing an optional M20 top hat and shall be finished in a textured polyurethane with external dimensions of (H) 557 mm x (W) 1100 mm x (D) 636 mm (21.9" x 43.3" x 25"). Weight is 78.87 kg (173.9 lbs).

Performance specifications of a typical production unit shall be as follows: frequency response of 30 Hz – Preset dependent (-10 dB IEC 60268-5); 2400 W long-term program per voice coil using EIA RS-426A pink noise (6 dB crest factor); pressure sensitivity of 100 dB at one Watt 100 Hz – 10 kHz at one metre; rated nominal impedance of 4  $\Omega$ .

The low frequency transducer shall be constructed on a resonant free and heavy-duty basket design with a 4" (101.6mm) voice coil, wound with copper wire on a high-quality former for high power handling and long-term reliability.

The wiring connection shall be as follows: a removable, lockable Phoenix connector with four screw-down terminals (one pair for input and one pair for link through to another loudspeaker) to provide secure wiring and allow for pre-wiring of the connector before the installation (this connector should then screw lock to the enclosure for secure attachment). In addition, a 4-pin locking connector shall also feature.

The loudspeaker system shall be a Void Acoustics Venu 218 V2.

# 9 Appendix C: Architectural Specifications

## Venu 208 Architectural Specifications

The loudspeaker shall be comprised of two high power 8" (203.2 mm) low frequency (LF) transducers.

The enclosure shall be rectangular constructed from 15 mm multi-laminated birch plywood with a wraparound grille and a rotating badge; it shall have integral threaded inserts for the fitment of wall and ceiling mounting hardware; it shall be finished in a textured polyurethane with external dimensions of (H) 203 mm x (W) 600 mm x (D) 475 mm (8" x 23.6" x 18.7") and weigh 20 kg (44 lbs).

The wiring connection shall be as follows: a removable, lockable wiring connector with four screw-down terminals (one pair for input and one pair for link through to another loudspeaker) to provide secure wiring and allow for pre-wiring of the connector before the installation (this connector should then screw lock to the enclosure for secure attachment). In addition, a 4-pin locking connector shall also feature.

Performance specifications of a typical production unit shall be as follows: frequency response of 38 Hz – Preset dependent (-10 dB IEC 60268-5); 300 W long-term program per voice coil using IEC268-5 pink noise (6 dB crest factor); pressure sensitivity of 119 dB cont, 125 dB peak at one Watt at one metre; rated nominal impedance of 8  $\Omega$ .

The low frequency transducer shall be constructed on a cast aluminium frame with a treated paper cone, 50.8 mm (2") voice coil, wound with copper wire on a high-quality voice coil former for high power handling and long-term reliability.

The loudspeaker system shall be a Void Acoustics Venu 208.

# 10 Appendix D: Bracket Matrix

	T80		T80XL		Yoke Bracket		T80 Ceiling Mount		Venu V2 Top Hat		T75 Wall Bracket		Heavy Duty Top Hat		T75 Ceiling Bracket	
	White	Black	White	Black	White	Black	White	Black	White	Black	White	Black	White	Black	White	Black
Venu 6	IT1109	IT1107					IT1106	IT1105	IT3474	IT3473						
Venu 8	IT1109	IT1107			IT3099	IT1131	IT1106	IT1105	IT3474	IT3473						
Venu 10			IT1115	IT1114	IT2300	IT1129	IT1106	IT1105	IT3474	IT3473						
Venu 12			IT1115	IT1114	IT2023	IT1130	IT1106	IT1105	IT3474	IT3473						
Venu 14			IT1115	IT1114	IT5899	IT5895	IT1106	IT1105	IT3474	IT3473						
Venu 15			IT1115	IT1114	IT2942	IT2941	IT1106	IT1105	IT3474	IT3473						
Venu 112			IT1115	IT1114	IT2921	IT2920					IT1133	IT1132	IT2042	IT2041	IT1905	IT1140
Venu 212					IT2924	IT2923							IT2042	IT2041		
Venu 115					IT2925	IT2926					IT1133	IT1132	IT2042	IT2041	IT1905	IT1140
Venu 215													IT2042	IT2041		
Venu 118													IT2042	IT2041		
Venu 218													IT2042	IT2041		
Venu 208					IT3216	IT3215					IT1133	IT1132			IT1905	IT1140

# 10 Appendix E: Changelog

## Changelog

Document Version	Notes	Valid for S.N
UG10579-2.4	Updated specs to IEC 60268-5	All

## NORTH AMERICA

Void Acoustics North America

Call: +1 (630) 686 6616

Email: [sales.usa@voidacoustics.com](mailto:sales.usa@voidacoustics.com)

## HEAD OFFICE

Void Acoustics Research Ltd

Unit L, The Fulcrum

Vantage Way

Poole, Dorset

BH12 4NU

United Kingdom

Call: +44(0) 1202 666006

Email: [hello@voidacoustics.com](mailto:hello@voidacoustics.com)



Hear. Feel. Connect.

[voidacoustics.com](http://voidacoustics.com)