

VOID

Hear. Feel. Connect.

voidacoustics.com



Nexus 6

Captivating efficiency, innovative form

USER GUIDE V2.5

©2026 Void Acoustics Research Ltd.

This user guide is subject to change without notice.
For the latest online version, visit: www.voidacoustics.com

Void Acoustics and the Void logo are registered trademarks of Void Acoustics Research Ltd. in the United Kingdom, USA and other countries; all other Void trademarks are the property of Void Acoustics Research Ltd.

Contents

1	Safety and Regulations	4
1.1	Important Safety Instructions	4
1.2	Limitations	4
1.3	EC Declaration of Conformity	4
1.4	UKCA Conformity	4
1.5	Warranty Statement	4
1.6	WEEE Directive	4
2	Unpacking and Checking	5
3	About	6
3.1	Welcome	6
3.2	Nexus 6 Overview	6
3.3	Key Features	6
3.4	Nexus 6 Specifications	7
3.5	Nexus 6 Dimensions	8
4	Cabling and Wiring	9
4.1	Electrical Safety	9
4.2	Cable Considerations for Fixed Installations	9
4.3	Nexus 6 Wiring Diagram - Before serial number N66293	10
4.4	Nexus 6 Wiring Diagram - After serial number N66293	11
4.5	Bias Q5 8-pin Locking Connector Wiring	12
4.6	Bias Q3 8-pin Locking Connector Wiring	12
5	Mounting	13
5.1	Installation Safety	13
5.2	Ground Stacking	14
5.3	Fly Frame & Rigging	18
5.4	Fly Frame Bracket Hole & Angle	20
6	Service	21
6.1	Return Authorisation	21
6.2	Shipping and Packing Considerations	21
7	Appendix	22
7.1	Architectural Specifications	22
7.2	Changelog	22

1 Safety and Regulations

1.1 Important safety instructions



The lightning flash with an arrowhead symbol within an equilateral triangle is intended to alert the user to the presence of uninsulated "dangerous voltage" within the product's enclosure that may be of sufficient magnitude to constitute a risk of electric shock to persons.



The exclamation point within an equilateral triangle is intended to alert the user of the presence of important operating and maintenance (servicing) instructions in the literature accompanying the appliance.

Safety instructions - read this first

1. Read these instructions.
2. Keep these instructions.
3. Heed all warnings.
4. Follow all instructions.
5. Do not use this apparatus near water.
6. Clean only with a dry cloth.
7. Do not block any ventilation openings. Install in accordance with the manufacturer's instructions.
8. Do not install near any heat source such as radiators, heat registers, stoves, or other such apparatus that produce heat.
9. Do not defeat the safety purpose of the grounding-type plug. A grounding type plug has two blades and a third grounding prong. The third prong is provided for your safety. If the provided plug does not fit into your outlet, consult an electrician for replacement of the obsolete outlet.
10. Protect power cords from being walked on or pinched particularly at plugs, convenience receptacles, and the point where they exit the apparatus.
11. Only use attachments and accessories specified by Void Acoustics.
12. Only use with the cart, stand, tripod, bracket, or table specified by the manufacturer, or sold with the apparatus. When a cart is used, use caution when moving the cart/apparatus combination to avoid injury from tip-over.
13. Unplug the apparatus during lightning storms or when unused for long periods of time.
14. Refer all servicing to qualified service personnel. Servicing is required when the apparatus has been damaged in any way, such as when the power-supply cord or plug is damaged, liquid has been spilled or objects have fallen into the apparatus, the apparatus has been exposed to rain or moisture, does not operate normally, or has been dropped.
15. Since the mains power supply cord attachment plug is used to disconnect the device, the plug should always be easily accessible.
16. Void loudspeakers can produce sound levels capable of causing permanent hearing damage from prolonged exposure. The higher the sound level, the less exposure needed to cause such damage. Avoid prolonged exposure to the high sound levels from the loudspeaker.

1.2 Limitations

This guide is provided to help familiarise the user with the loudspeaker system and its accessories. It is not intended to provide comprehensive electrical, fire, mechanical and noise training and is not a substitute for industry-approved training. Nor does this guide absolve the user of their obligation to comply with all relevant safety legislation and codes of practice. While every care has been taken in creating this guide, safety is user-dependent and Void Acoustics Research Ltd cannot guarantee complete safety whenever the system is rigged and operated.

1.3 EC declaration of conformity

For EC Declaration of Conformity please go to:

www.voidacoustics.com/eu-declaration-loudspeakers

1.4 UKCA marking

For details of the UKCA marking go to:

www.voidacoustics.com/uk-declaration-loudspeakers

1.5 Warranty statement

For warranty statement go to:

1.6 WEEE directive

If the time arises to throw away your product, please recycle all the components possible.



This symbol indicates that when the end-user wishes to discard this product, it must be sent to separate collection facilities for recovery and recycling. By separating this product from other household-type waste, the volume of waste sent to incinerators or land-fills will be reduced and natural resources will thus be conserved.

The Waste Electrical and Electronic Equipment Directive (WEEE Directive) aims to minimise the impact of electrical and electronic goods on the environment. Void Acoustics Research Ltd complies with the Directive 2002/96/EC and 2003/108/EC of the European Parliament on waste electrical and electronic equipment (WEEE) in order to reduce the amount of WEEE that is being disposed of in land-fill sites. All of our products are marked with the WEEE symbol; this indicates that this product must NOT be disposed of with other waste. Instead it is the user's responsibility to dispose of their waste electrical and electronic equipment by handing it over to an approved reprocessor, or by returning it to Void Acoustics Research Ltd for reprocessing. For more information about where you can send your waste equipment for recycling, please contact Void Acoustics Research Ltd or one of your local distributors.



2 Unpacking and Checking

All Void Acoustics products are carefully manufactured and thoroughly tested before being despatched. Your dealer will ensure that your Void products are in pristine condition before being forwarded to you but mistakes and accidents can happen.

Before signing for your delivery:

- Inspect your shipment for any signs of contamination, abuse or transit damage as soon as you receive it
- Check your Void Acoustics delivery fully against your order
- If your shipment is incomplete or any of its contents are found to be damaged; inform the shipping company and inform your dealer.

Nexus 6 loudspeakers are heavy (75.5 kg (166.5 lbs)) and require a minimum three people to lift.

- Undo the four butterfly catches on the transport case then remove the lid making sure the lid is clear before moving sideways
- If you need to place the Nexus 6 on a flat surface ensure you use a lint free product to protect the finish
- When removing the Nexus 6 take care not to damage the lower tray of the transport case.

Keep the original packaging in case you need to return a product for service later.

See section 1.5 for warranty conditions and see section 6 if your product needs servicing.

3 About

3.1 Welcome

Many thanks for purchasing this Void Acoustics Nexus 6. We truly appreciate your support. At Void, we design, manufacture and distribute advanced professional audio systems for the installed and live sound market sectors. Like all Void products, our highly skilled and experienced engineers have successfully combined pioneering technologies with ground-breaking design aesthetics, to bring you superior sound quality and visual innovation. In buying this product, you are now part of the Void family and we hope using it brings you years of satisfaction. This guide will help you both use this product safely and ensure it performs to its full capability.

3.2 Nexus 6 overview

Ideal for larger venues, the two-way Nexus 6 has an innovative internal transducer layout and 20 high power drivers, housed in a sculpted fibreglass enclosure. Virtual Arc technology forms a common acoustic centre at the back of the array, overcoming all the disadvantages of a traditional array where multiple sound sources emit from different locations. Instead, dispersion, phase, coherency and timing are all controlled and unified, ensuring the same sound is experienced by the audience, regardless of where they are standing. Whether placed on low frequency enclosures to form a stance stack or flown independently, the Nexus 6 provides intelligent performance and styling.

3.3 Key features

- Visually striking appearance for style-led environments
- Virtual Arc technology forms common acoustic centre
- Wide 110° horizontal dispersion with coherent phase and timing
- 20 discrete proprietary drive units
- Optional ground stand, fly frame or wall bracket
- Fibreglass composite construction
- 2-way with gain shading
- Available as standard in red with a black grille. Custom RAL and KROME finishes are available upon request

3 About

3.4 Nexus 6 specifications

Frequency Response ¹	115 Hz - 20 kHz
Maximum Output ²	137 dB cont, 143 dB peak
Nominal Dispersion	110°H x 60°V
Sensitivity ³	LF: 105 dB 1W/1m, HF: 110 dB 1W/1m
Driver Configuration	12 x 6.5" LF, 8 x 1" HF compression driver
Power Handling	LF: 2 x 1350 W AES, HF: 2 x 160 W AES
Nominal Impedance	LF: 2 x 5.3 Ω , HF: 2 x 4 Ω
Suggested Minimum Amplifier	Bias Q3
Weight	75.5 kg (166.5 lbs)
Connections	1 x 8-pin locking connector
Enclosure	Fibreglass composite
Finish	Smooth cellulose
Mounting	Ground stand, wall bracket or fly frame
Height	1267 mm (49.8")
Width	562 mm (22.1")
Depth	430 mm (16.9")

¹ -10 dB IEC 60268-5 ² Calculated ³ Measured in half space

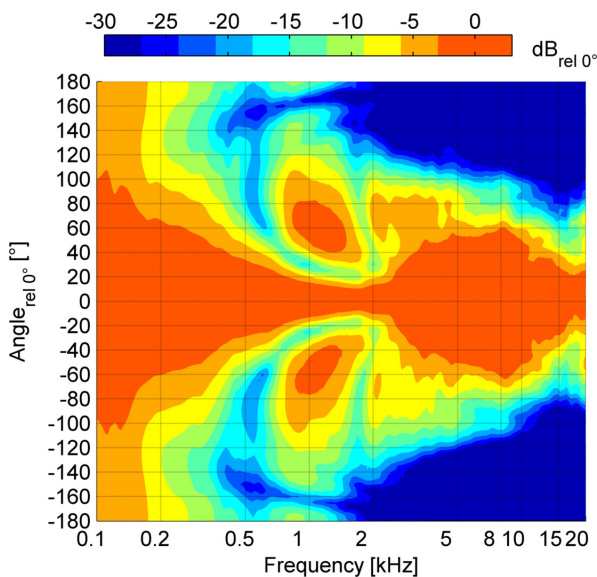

Figure 3.1: Horizontal directivity isobars

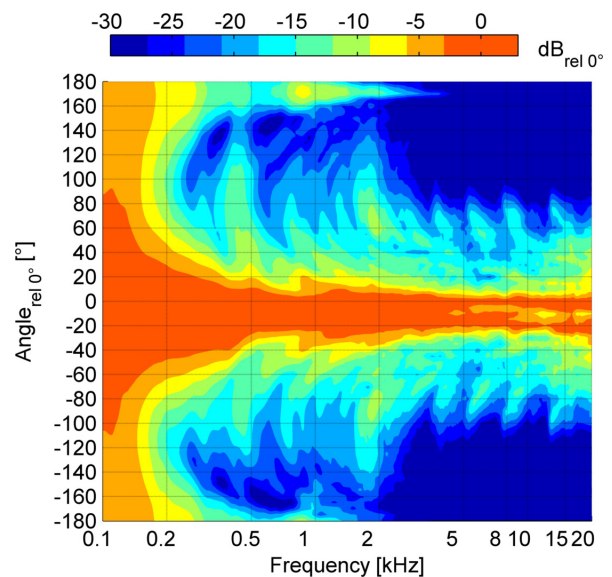

Figure 3.2: Vertical directivity isobars

3 About

3.5 Nexus 6 dimensions

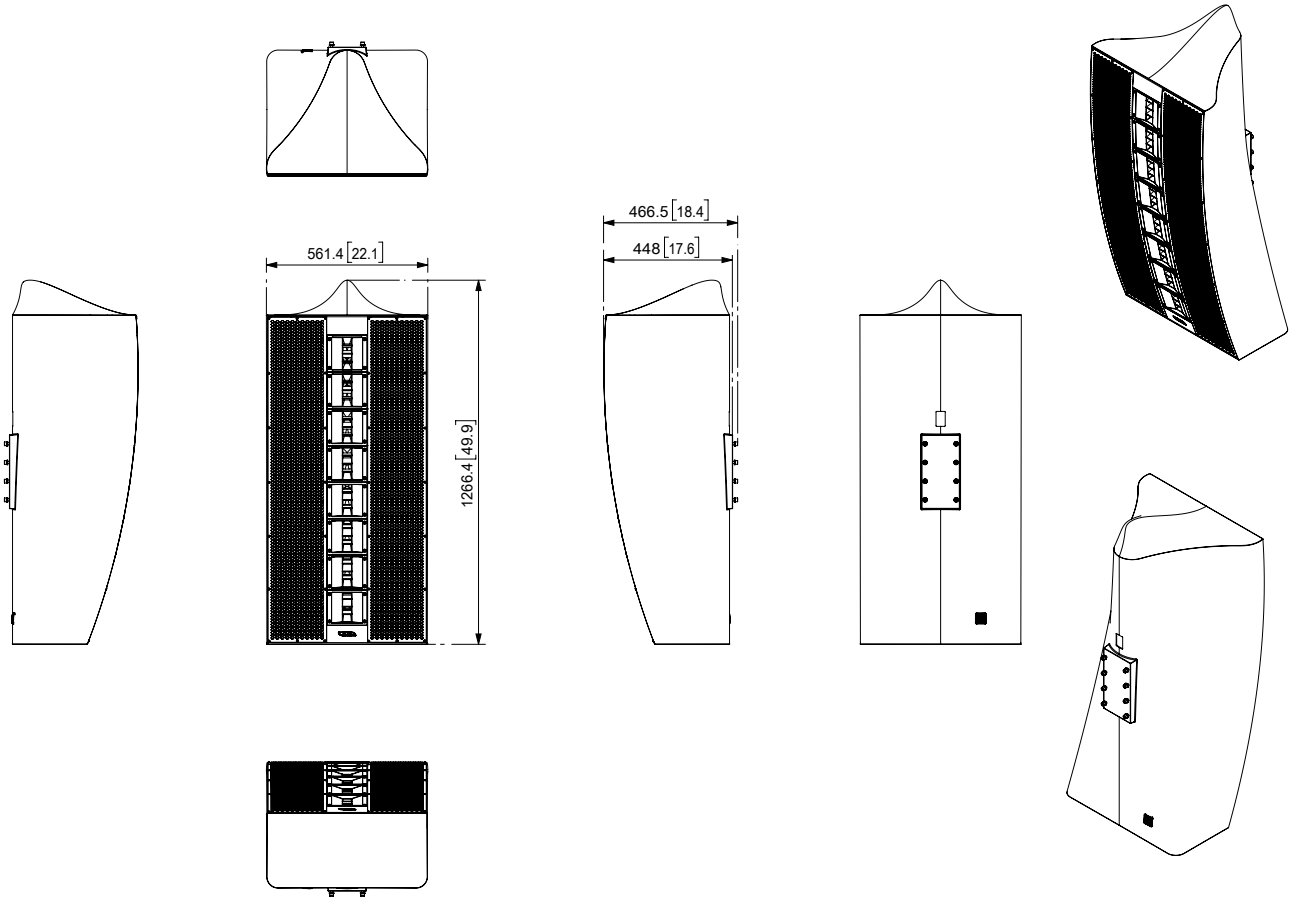

Figure 3.3: Dimensions

4 Cable and Wiring

4.1 Electrical safety



To avoid electrical hazards please note the following:

- Do not access the inside of any electrical equipment. Refer servicing to Void-approved service agents.

4.2 Cable considerations for fixed installations

We recommend specifying installation-grade Low Smoke Zero Halogen (LSZH) cables for permanent installations. The cables should use Oxygen Free Copper (OFC) of grade C11000 or above. Cables for permanent installations should be compliant with the following standards:

- IEC 60332.1 Fire retardancy of a single cable
- IEC 60332.3C Fire retardancy of bunched cables
- IEC 60754.1 Amount of Halogen Gas Emissions
- IEC 60754.2 Degree of acidity of released gases
- IEC 61034.2 Measurement of smoke density.

We suggest using the following maximum copper cable lengths to keep level losses below 0.6 dB.

Metric mm ²	Imperial AWG	4 Ω load
2.50 mm ²	13 AWG	18 m
4.00 mm ²	11 AWG	30 m

4 Cable and Wiring

4.3 Nexus 6 wiring diagram applicable for serial numbers **before** N66293

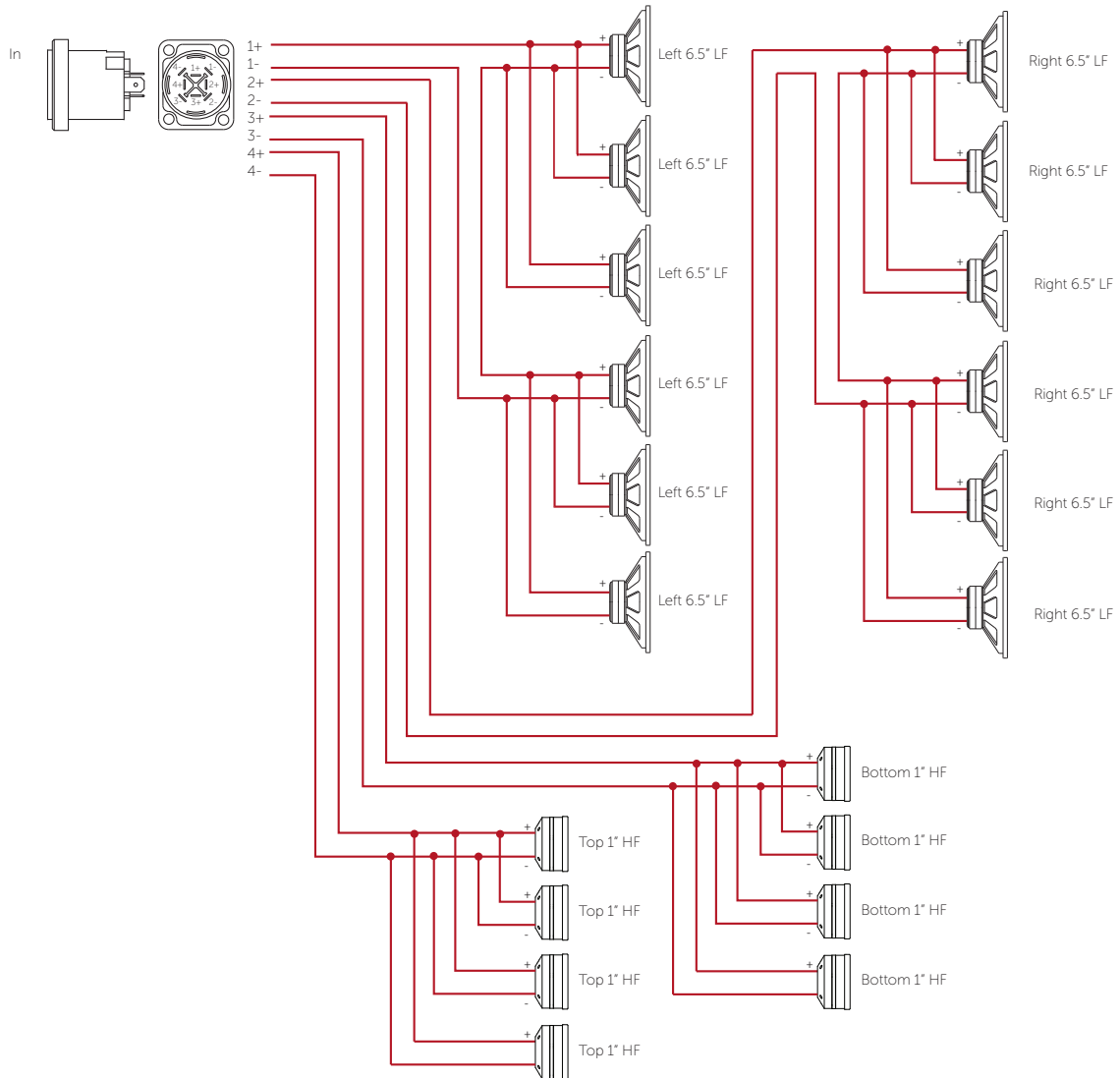

Figure 4.1: Wiring diagram

8-pin locking connector assignments			
Pins	Driver	Power handling	Impedance
+/-1	Left side 6 x 6.5" LF	1350 W AES	5.3 Ω
+/-2	Right side 6 x 6.5" LF	1350 W AES	5.3 Ω
+/-3	Bottom 4 x 1" HF	160 W AES	4 Ω
+/-4	Top 4 x 1" HF	160 W AES	4 Ω

4 Cable and Wiring

4.4 Nexus 6 wiring diagram applicable for serial numbers N66293 onwards

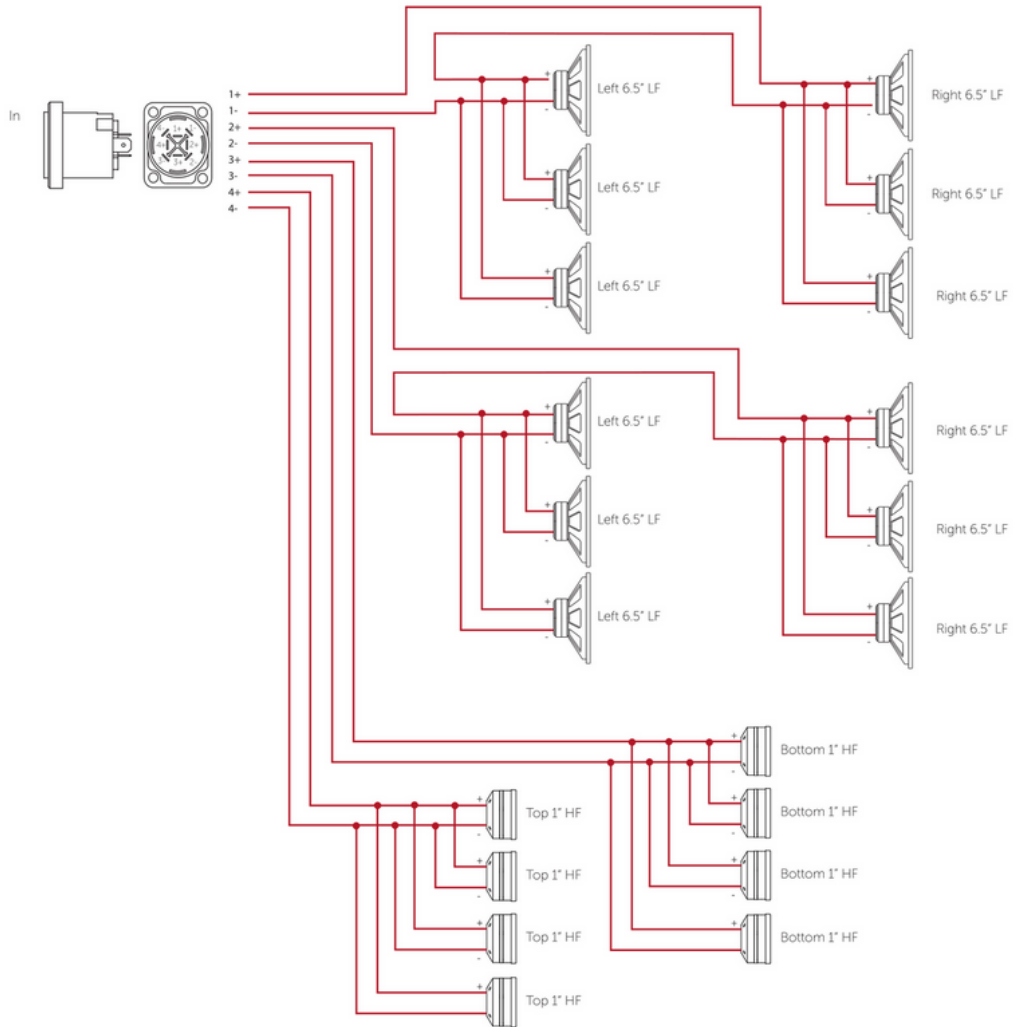

Figure 4.2: Wiring diagram

8-pin locking connector assignments			
Pins	Driver	Power handling	Impedance
+/-1	Top 6 x 6.5" LF	1350 W AES	5.3 Ω
+/-2	Bottom 6 x 6.5" LF	1350 W AES	5.3 Ω
+/-3	Bottom 4 x 1" HF	160 W AES	4 Ω
+/-4	Top 4 x 1" HF	160 W AES	4 Ω

4 Cable and Wiring

4.5 Bias Q5 8-pin locking connector wiring

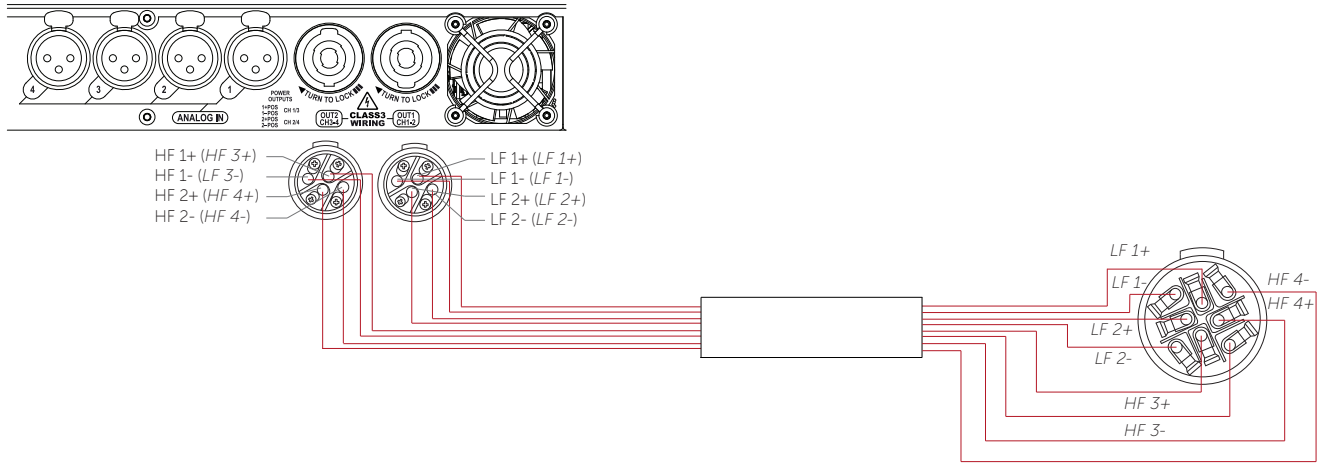

Figure 4.3: Bias Q5

Bias Q5				
	Output 1		Output 2	
Channel	Channel 1	Channel 2	Channel 3	Channel 4
Output	Top 6 LF x 6.5"	Bottom 6 LF x 6.5"	Bottom HF 4 x 1"	Top HF 4 x 1"
8-pin locking connector	+/-1	+/-2	+/-3	+/-4

4.6 Bias Q3 8-pin locking connector wiring

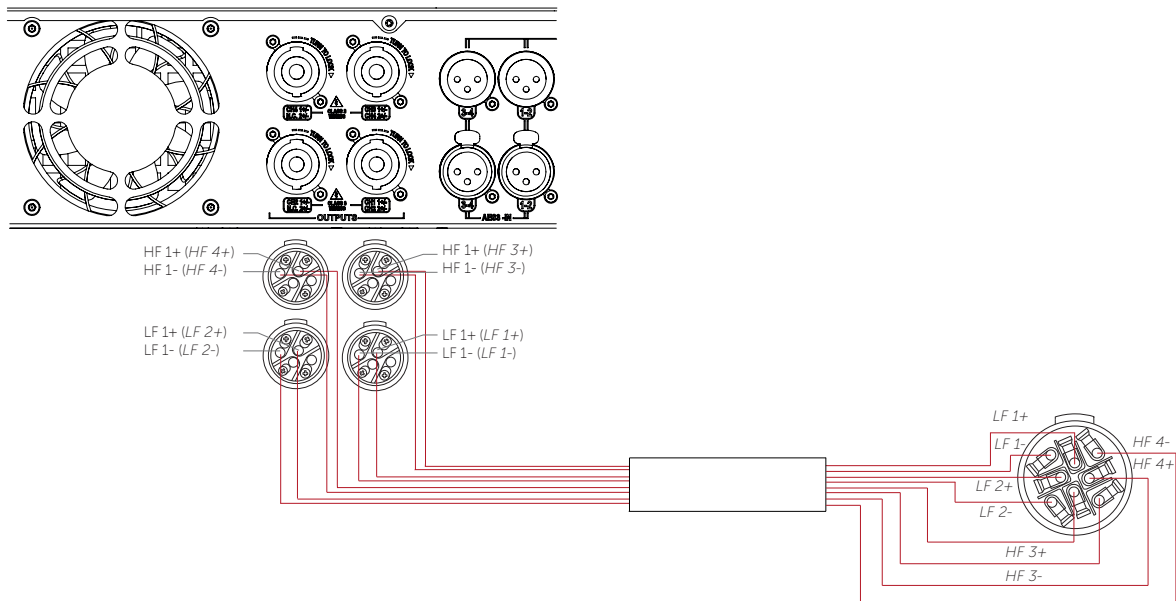

Figure 4.4: Bias Q3

Bias Q3				
	Output 1		Output 2	
Channel	Channel 1	Channel 2	Channel 3	Channel 4
Output	Top 6 LF x 6.5"	Bottom 6 LF x 6.5"	Bottom HF 4 x 1"	Top HF 4 x 1"
8-pin locking connector	+/-1	+/-2	+/-3	+/-4

5 Mounting

5.1 Installation safety

To avoid mechanical hazards, please note the following:



- Safety regulations vary in different regions. Full compliance with those regulations must be your priority
- Installations must only be undertaken by fully qualified and experienced engineers/technicians who understand local regulations
- This may include consulting a structural engineer before installation of wall brackets
- Remember that all personnel have a duty of care to themselves, to their assistants, to the venue staff and to the public
- Before lifting any part of the system above head height, check the whole rig for loose tools or other items that may fall and cause injury
- Do not use a telephone (even if hands-free) whilst installing. Always concentrate fully on the installation operation
- Do not install equipment that is worn, damaged, corroded, mishandled or overstressed in any way
- Use only Void-approved mounting equipment and accessories
- Secondary safeties should be provided in all instances where cabinets are flying or fixing overhead and should conform to local regulations

5.2 Ground Stacking & Wall Mounting

Step 1:

Removing the backing plate from the Nexus 6 bracket by removing the M8 and M12 bolts from the bracket assembly.

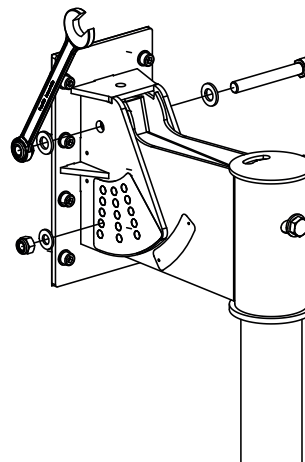

Figure 5.1: Backing plate removal

Step 2:

Remove all eight M8 bolts from the rear of the Nexus 6 loudspeaker.

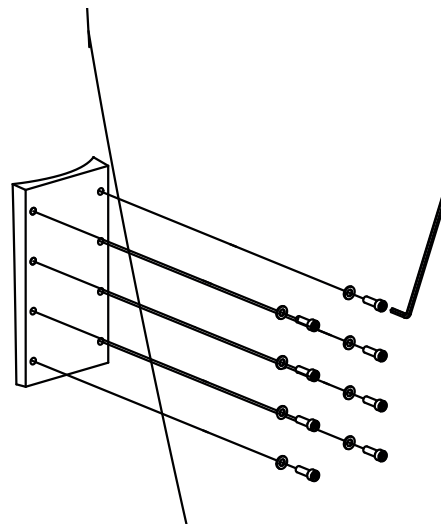

Figure 5.2: M8 bolt removal

Step 3:

Attached the backing plate to the Nexus 6 ensuring that all eight M8 bolts are securely fastened.

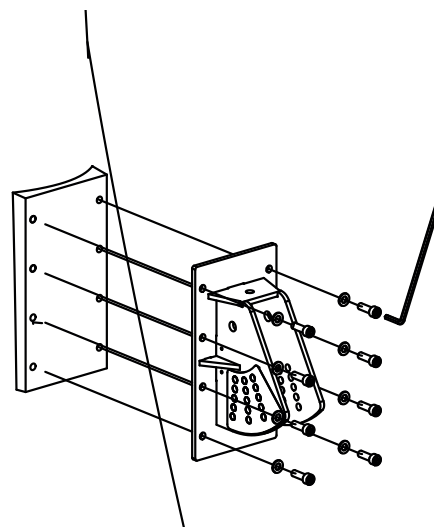

Figure 5.3: Backing plate attachment

5.2 Ground Stacking & Wall Mounting

Step 4:

Carefully lower the Nexus 6 loudspeaker into position onto the bracket assembly.

Note: Nexus 6 loudspeakers are heavy and require a minimum of three people to lift. At this stage of the mounting procedure it becomes necessary to have four people, three to lift the Nexus 6 loudspeaker and one to attach the bracket.

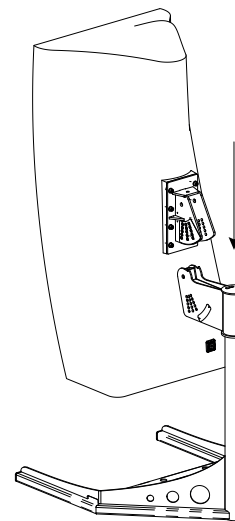

Figure 5.4: Nexus 6 positioning

Step 5:

With the lifting equipment still in place attach the M12 bolt to the bracket assembly.

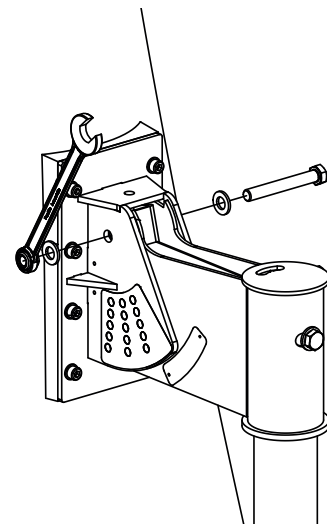

Figure 5.5: M12 bolt attachment

Step 6:

Adjust the vertical angle required using the datum line to select the required angle (shown here set to zero degrees indicated in yellow). The Nexus 6 bracket is capable of negative angle adjustment to point down (indicated in black) and positive angle to point up (indicated in red). The corresponding hole for each angle is indicated by that number and its colour.

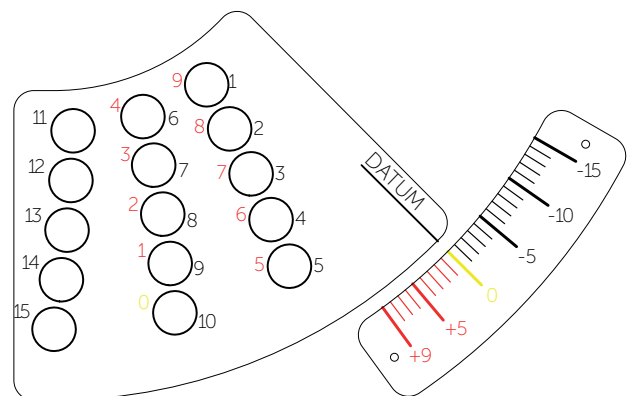

Figure 5.6: Angle selection

5.2 Ground Stacking & Wall Mounting

Step 7:

Once the vertical angle has been selected attach the M8 bolt through the appropriate slot.

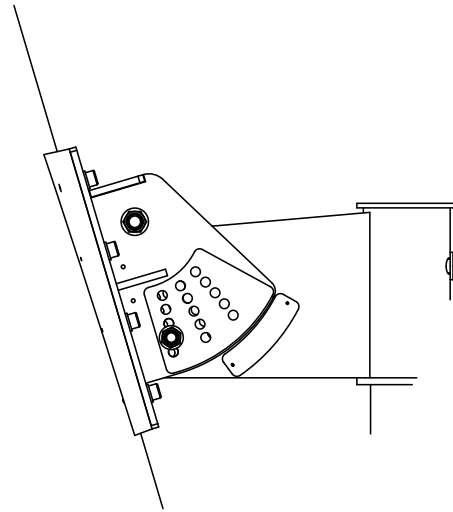

Figure 5.7: M8 bolt replacement

Step 8:

Loosen, but do not remove, the M8 bolt from the rear of the bracket assembly.

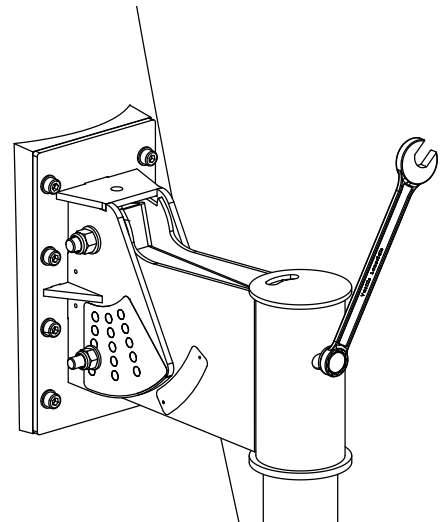

Figure 5.8: M8 bolt loosening

Step 9:

Adjust the horizontal angle of the Nexus 6 to the desired direction using the angle finder on the top of the bracket assembly.

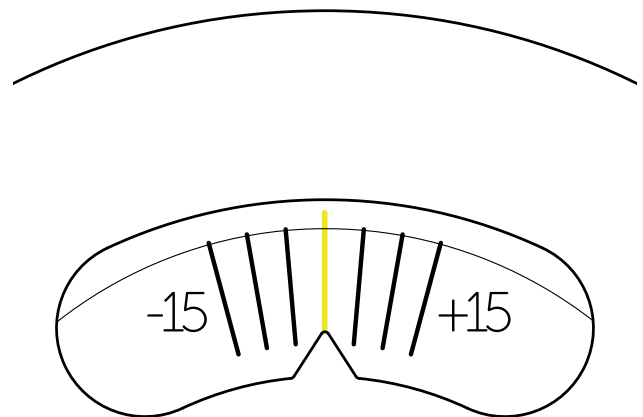

Figure 5.9: Horizontal angle adjustment

5.2 Ground Stacking & Wall Mounting

Step 10:

Secure the M8 bolt on the rear of the bracket assembly but ensure not to over tighten the bolt as it may cause damage to the nut and bracket assembly.

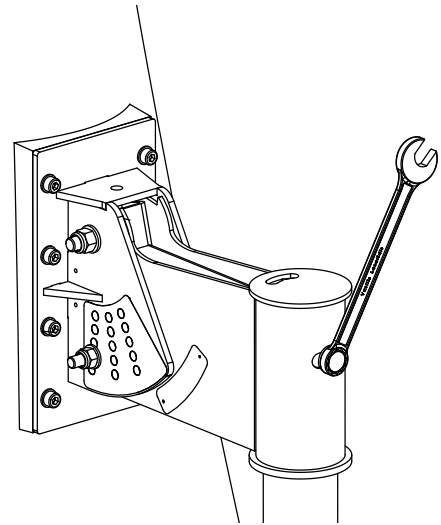

Figure 5.10: Securing the horizontal angle

For Wall Mounting

Always secure the wall mount to the wall before attaching the Nexus 6, then follow steps 1-10 above.

Safety Notice: Wall Mount Installation



This product must be installed by a competent and qualified **professional** with experience in structural mounting and load-rated fixings.

All wall fasteners must be rated to withstand a **minimum load of 7.5 kN**. It is the responsibility of the installer to ensure that the supporting wall structure and selected fixings are suitable for the applied loads.

Improper installation may result in serious injury, death, or damage to property. Always follow local building codes and best practices for load-bearing wall mounts.

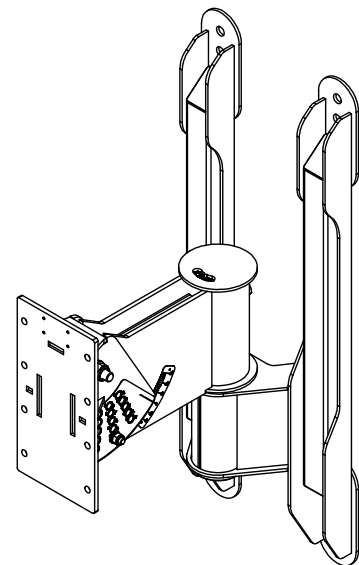

Figure 5.11: Nexus 6 Wall Bracket

5.3 Fly Frame & Rigging

Step 1

Remove the two M12 fasteners from the Nexus 6 backing plate

Note: Nexus 6 loudspeakers are heavy and require a minimum of three people to lift. It is therefore recommended to secure the fly frame onto the Nexus 6 whilst still laying down in its travel case.

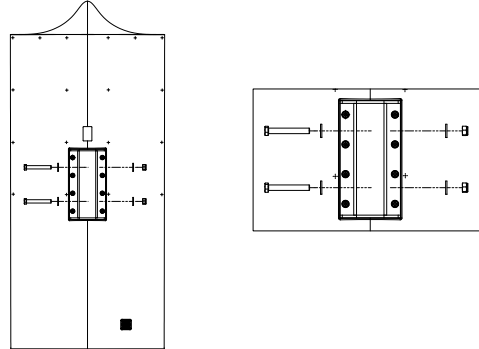

Figure 5.12: Removing M12 fasteners from Nexus 6

Step 2

Secure the M12 fasteners through the backing plate and fly frame

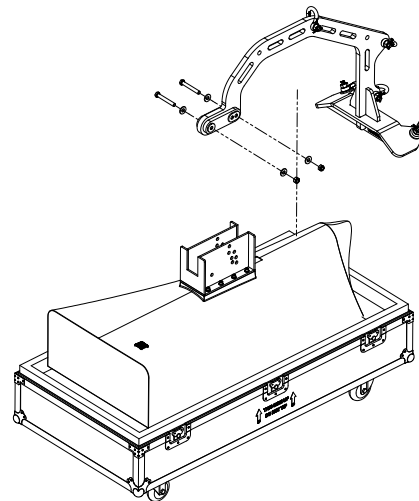

Figure 5.13: Securing fly frame to Nexus 6

Step 3

Use an appropriate hoist and lift the Nexus 6 from the shackles located at the top of the fly frame arrowed.

Note: Take care when lifting to not scratch the Nexus 6 on the travel case.

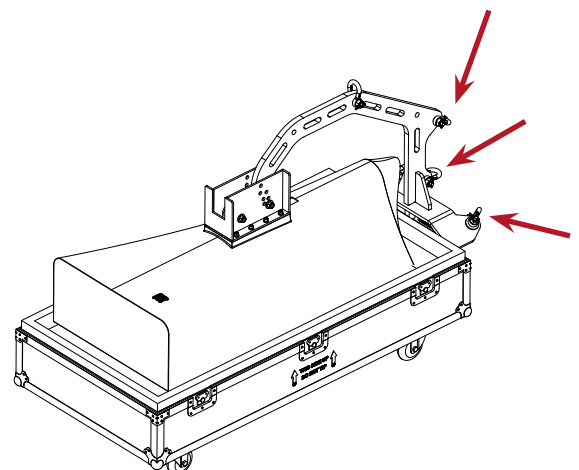

Figure 5.14: Hoist shackle points

5.3 Fly Frame & Rigging

Step 4

Three-point lift shackle locations for lifting the Nexus 6 are marked by the red arrows

The orange arrow shackle is used as the secondary safety attachment point (preferably not attached to the main pick-up point.)

The green arrow shackle is optional, and is used to anchor the speaker in the case that there is some swaying or swinging of the Nexus 6.

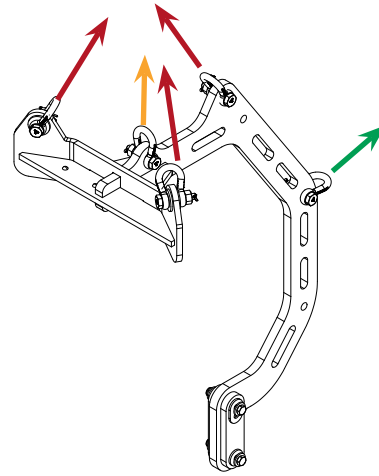

Figure 5.15: Shackle positions

Step 5

Support the weight of the Nexus 6 and remove the top M-12 fastener.

Move the bracket to the required angle hole and reinstall the M-12 fastener to secure.

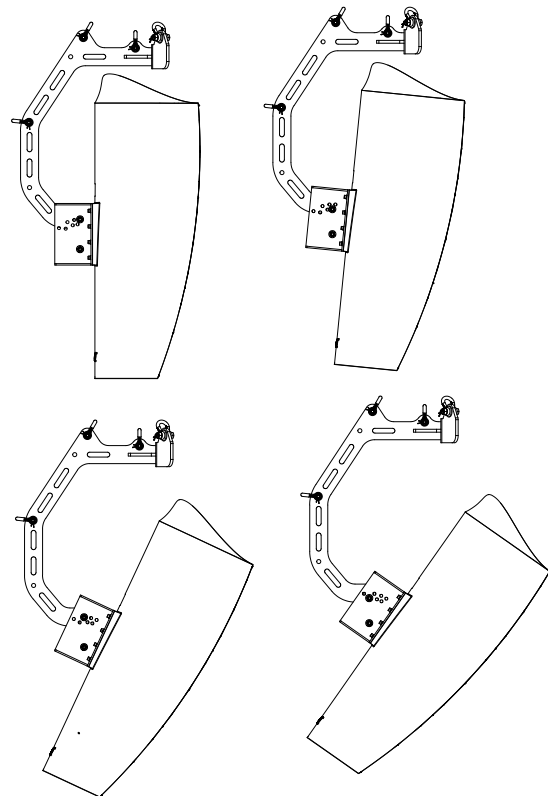

Figure 5.16: Adjusted angles on Nexus 6

5.4 Fly Frame Bracket Hole and Angle

Hole	Speaker Angle
1	0°
2	-6°
3	-12°
4	-17°
5	-25°
6	-35°
7	-45°

6 Service

Void Nexus 6 loudspeakers should only be serviced by a fully-trained technician.



No user serviceable parts inside. Refer servicing to your dealer.

6.1 Return authorisation

Before returning your faulty product for repair, please remember to get an R.A.N. (Return Authorisation Number) from the Void dealer who supplied the system to you. Your dealer will handle the necessary paperwork and repair. Failure to go through this return authorisation procedure could delay the repair of your product.

Note that your dealer will need to see a copy of your sales receipt as proof of purchase so please have this to hand when applying for return authorisation.

6.2 Shipping and packing considerations

- When sending a Void Nexus 6 loudspeaker to an authorised service centre, please write a detailed description of the fault and list any other equipment used in conjunction with the faulty product.
- Accessories will not be required. Do not send the instruction manual, cables or any other hardware unless your dealer asks you to.
- Pack your unit in the original factory packaging if possible. Include a note of the fault description with the product. Do not send it separately.
- Ensure safe transportation of your unit to the authorised service centre.

7 Appendix

7.1 Architectural Specifications

The loudspeaker shall be a two-way system consisting of twelve high power 6.5" (165.1 mm) direct radiating low frequency (LF) transducers, and eight 1" (25.4 mm) high frequency (HF) compression drivers, each mounted on a dedicated waveguide.

With twenty discrete proprietary drive units, Virtual Arc technology is implemented on every component to form a common virtual point source rearwards of the array resulting in a better and more controlled directivity, coherence, phase and time alignment between all components.

The LF transducers shall be constructed on a cast aluminium frame, with a treated paper cone, 44 mm (1.7") voice coil, wound with copper wires on a high quality voice coil former and neodymium magnets, for high power handling and long term-reliability. The HF transducers shall project their sound through a high precision constant directivity wave-guide, with a 76.2 mm (3") baffle diameter, to achieve directivity pattern control between the different drivers with no cancellations and low distortion.

Performance specifications for a typical production unit shall be as follows: the usable on-axis bandwidth shall be 115 Hz to 20 kHz (-10 dB IEC 60268-5) and shall average 60° directivity pattern on the vertical axis and 110° on the horizontal one (-6 dB down from on-axis level) from 1 kHz to 12 kHz; maximum SPL of 143 dB peak measured at 1 m using IEC60268-5 pink noise. Power handling shall be 2700 W AES for the LF section at a rated impedance of 2 x 5.3 Ω and 640 W AES for the HF section at a rated impedance 2 x 4 Ω . The system shall be powered by its own dedicated power amplification modules with DSP management, from which crossover points will also be set, with the wiring connection via one 8-pin locking connector.

The enclosure shall be of a special fibreglass composite with a smooth cellulose finish of any RAL colour. The system shall be stack mounted with a dedicated stand or can also be suspended with a load tested suspension system. The external dimensions of the enclosure shall be (W) 561 mm x (H) 1266 mm x (D) 430 mm (22.1" x 49.8" x 16.9"). Weight shall be 75.5 kg (166.5 lbs) including stand.

The loudspeaker shall be the Void Acoustics Nexus 6.

7.2 Changelog

Document Version	Notes	Valid for S.N
UG10572-2.5	Updated specs to IEC 60268-5. Fly bar bracket hole & angle sections added.	NXLXXX - Current

NORTH AMERICA

Void Acoustics North America

Call: +1 630 686 6616

Email: sales.usa@voidacoustics.com

HEAD OFFICE

Void Acoustics Research Ltd

Unit L, The Fulcrum

Vantage Way

Poole

Dorset

BH12 4NU

Call: +44(0) 1202 666006

Email: hello@voidacoustics.com



Hear. Feel. Connect.

voidacoustics.com