

**VOID**

Hear. Feel. Connect.

[voidacoustics.com](http://voidacoustics.com)



# Cyclone 4

Compact Fidelity Starts Here

USER GUIDE V1.2

©2026 Void Acoustics Research Ltd.

This user guide is subject to change without notice.  
For the latest online version, visit: [www.voidacoustics.com](http://www.voidacoustics.com)

Void Acoustics and the Void logo are registered trademarks of Void Acoustics Research Ltd. in the United Kingdom, USA and other countries; all other Void trademarks are the property of Void Acoustics Research Ltd.

# Contents

<b>1</b>	<b>Safety and Regulations</b>	<b>4</b>
1.1	Important Safety Instructions	4
1.2	Limitations	4
1.3	EC Declaration of Conformity	4
1.4	UKCA Conformity	4
1.5	Warranty Statement	4
1.6	WEEE Directive	4
<b>2</b>	<b>Unpacking and Checking</b>	<b>5</b>
<b>3</b>	<b>About</b>	<b>6</b>
3.1	Welcome	6
3.2	Cyclone 4 Overview	6
3.3	Key Features	6
3.4	Cyclone 4 Specifications	7
3.5	Cyclone 4 Dimensions	8
<b>4</b>	<b>Cable and Wiring</b>	<b>9</b>
4.1	Electrical Safety	9
4.2	Cable Considerations for Fixed Installations	9
4.3	Phoenix Connector Polarity	9
4.4	Cyclone Glanded connector wiring	10
4.5	Cyclone 4 Wiring Diagram	11
4.6	Bias D1/Q1/Q2 Phoenix Wiring	11
4.7	Bias Q3/Q5 NL4 Wiring	12
<b>5</b>	<b>Mounting</b>	<b>13</b>
5.1	Installations Safety	13
5.2	Wall Mounting	14
5.3	Ceiling Mounting	17
5.4	Stud Mount	19
5.5	Pole Mount	20
<b>6</b>	<b>Service</b>	<b>21</b>
<b>7</b>	<b>Appendix</b>	<b>22</b>
7.1	Application Note: Loudspeakers in Corrosive Environments	22
7.2	Architectural Specifications	23
7.3	Changelog	23

# 1 Safety and Regulations

## 1.1 Important safety instructions



The lightning flash with an arrowhead symbol within an equilateral triangle is intended to alert the user to the presence of uninsulated "dangerous voltage" within the product's enclosure that may be of sufficient magnitude to constitute a risk of electric shock to persons.



The exclamation point within an equilateral triangle is intended to alert the user of the presence of important operating and maintenance (servicing) instructions in the literature accompanying the appliance.

### Safety instructions - read this first

1. Read these instructions.
2. Keep these instructions.
3. Heed all warnings.
4. Follow all instructions.
5. Do not use this apparatus near water.
6. Clean only with a dry cloth.
7. Do not block any ventilation openings. Install in accordance with the manufacturer's instructions.
8. Do not install near any heat source such as radiators, heat registers, stoves, or other such apparatus that produce heat.
9. Do not defeat the safety purpose of the grounding-type plug. A grounding type plug has two blades and a third grounding prong. The third prong is provided for your safety. If the provided plug does not fit into your outlet, consult an electrician for replacement of the obsolete outlet.
10. Protect power cords from being walked on or pinched particularly at plugs, convenience receptacles, and the point where they exit the apparatus.
11. Only use attachments and accessories specified by Void Acoustics.
12. Only use with the cart, stand, tripod, bracket, or table specified by the manufacturer, or sold with the apparatus. When a cart is used, use caution when moving the cart/apparatus combination to avoid injury from tip-over.
13. Unplug the apparatus during lightning storms or when unused for long periods of time.
14. Refer all servicing to qualified service personnel. Servicing is required when the apparatus has been damaged in any way, such as when the power-supply cord or plug is damaged, liquid has been spilled or objects have fallen into the apparatus, the apparatus has been exposed to rain or moisture, does not operate normally, or has been dropped.
15. Since the mains power supply cord attachment plug is used to disconnect the device, the plug should always be easily accessible.
16. Void loudspeakers can produce sound levels capable of causing permanent hearing damage from prolonged exposure. The higher the sound level, the less exposure needed to cause such damage. Avoid prolonged exposure to the high sound levels from the loudspeaker.

## 1.2 Limitations

This guide is provided to help familiarise the user with the loudspeaker system and its accessories. It is not intended to provide comprehensive electrical, fire, mechanical and noise training and is not a substitute for industry-approved training. Nor does this guide absolve the user of their obligation to comply with all relevant safety legislation and codes of practice. While every care has been taken in creating this guide, safety is user-dependent and Void Acoustics Research Ltd cannot guarantee complete safety whenever the system is rigged and operated.

## 1.3 EC declaration of conformity

For EC Declaration of Conformity please go to:

[www.voidacoustics.com/eu-declaration-loudspeakers](http://www.voidacoustics.com/eu-declaration-loudspeakers)

## 1.4 UKCA marking

For details of the UKCA marking go to:

[www.voidacoustics.com/uk-declaration-loudspeakers](http://www.voidacoustics.com/uk-declaration-loudspeakers)

## 1.5 Warranty statement

For warranty statement go to:

<https://voidacoustics.com/terms-conditions/>

## 1.6 WEEE directive

If the time arises to throw away your product, please recycle all the components possible.



This symbol indicates that when the end-user wishes to discard this product, it must be sent to separate collection facilities for recovery and recycling. By separating this product from other household-type waste, the volume of waste sent to incinerators or land-fills will be reduced and natural resources will thus be conserved.

The Waste Electrical and Electronic Equipment Directive (WEEE Directive) aims to minimise the impact of electrical and electronic goods on the environment. Void Acoustics Research Ltd complies with the Directive 2002/96/EC and 2003/108/EC of the European Parliament on waste electrical and electronic equipment (WEEE) in order to reduce the amount of WEEE that is being disposed of in land-fill sites. All of our products are marked with the WEEE symbol; this indicates that this product must NOT be disposed of with other waste. Instead it is the user's responsibility to dispose of their waste electrical and electronic equipment by handing it over to an approved reprocessor, or by returning it to Void Acoustics Research Ltd for reprocessing. For more information about where you can send your waste equipment for recycling, please contact Void Acoustics Research Ltd or one of your local distributors.



## 2 Unpacking and Checking

All Void Acoustics products are carefully manufactured and thoroughly tested before being despatched. Your dealer will ensure that your Void products are in pristine condition before being forwarded to you but mistakes and accidents can happen.

Before signing for your delivery:

- Inspect your shipment for any signs of contamination, abuse or transit damage as soon as you receive it
- Check your Void Acoustics delivery fully against your order
- If your shipment is incomplete or any of its contents are found to be damaged; inform the shipping company and inform your dealer.

When you are removing your Cyclone 4 loudspeaker from its original packaging:

- Cyclone 4 loudspeakers come double boxed and are stapled shut; take care when unboxing and removing the staples to avoid injury or damage to the loudspeaker
- If you need to place the Cyclone 4 loudspeaker on a flat surface ensure you use a lint free product to protect the finish
- When you have removed the Cyclone 4 loudspeaker from the packaging inspect it to ensure there is no damage and keep all original packaging in case it needs to be returned for any reason.

See section 1.5 for warranty conditions and see section 6 if your product needs servicing.

# 3 About

## 3.1 Welcome

Many thanks for purchasing this Void Acoustics Cyclone 4. We truly appreciate your support. At Void, we design, manufacture and distribute advanced professional audio systems for the installed and live sound market sectors. Like all Void products, our highly skilled and experienced engineers have successfully combined pioneering technologies with ground-breaking design aesthetics, to bring you superior sound quality and visual innovation. In buying this product, you are now part of the Void family and we hope using it brings you years of satisfaction. This guide will help you both use this product safely and ensure it performs to its full capability.

## 3.2 Cyclone 4 overview

Providing exceptional sound quality in an ultra-compact IP-55 rated enclosure, Cyclone 4 is the latest addition to this extremely popular range. With its weather-protected casing, UV resilient paint and aluminium bracket, Cyclone 4 is the perfect audio solution for all-weather applications.

Cyclone 4 is the most compact loudspeaker within the range and contains a single 4 inch low frequency transducer with a 0.75 inch soft dome high frequency tweeter. Supplied as standard with a conventional wall bracket, the Cyclone 4 can also make use of the wide range of brackets that are available for the larger models, allowing for a quick and easy installation.

## 3.3 Key features

- Passive 4 inch coaxial loudspeaker
- Weather-resistant input glands with Phoenix connector and link-through functionality
- Compact ABS enclosure
- Conical 80° dispersion
- 16 ohm impedance allowing scalable system wiring
- Stainless steel grille and fasteners
- Supplied with an aluminium T51 wall bracket
- Weather-protected with an IP-55 rating
- UV resilient finish
- Available as standard in red with a black grille, black with a black grille, and white with a white grille. Custom RAL and KROME finishes are available upon request

# 3 About

## 3.4 Cyclone 4 Specifications

Frequency Response <sup>1</sup>	85 Hz - 17.8 kHz
Maximum Output <sup>2</sup>	101 dB cont, 107 dB peak
Nominal Dispersion	80°H x 80°V
Sensitivity <sup>3</sup>	87 dB 1W/1m
Driver Configuration	1 x 4" LF, 1 x 0.75" soft dome HF tweeter
Power Handling	30 W AES
Nominal Impedance	16 $\Omega$
Suggested Minimum Amplifier	Inca 500 / Bias Q1+
Weight	1.3 kg (2.7 lbs)
IP Rating	IP-55
Connections	Phoenix connectors with link out
Enclosure	ABS
Finish	Smooth cellulose
Mounting	Wall bracket included, Type 51 plate
Height	150 mm (5.9")
Width	179 mm (7.1")
Depth	175 mm (6.9")

1 -10 dB IEC 60268-5 2 Calculated 3 Measured in half space

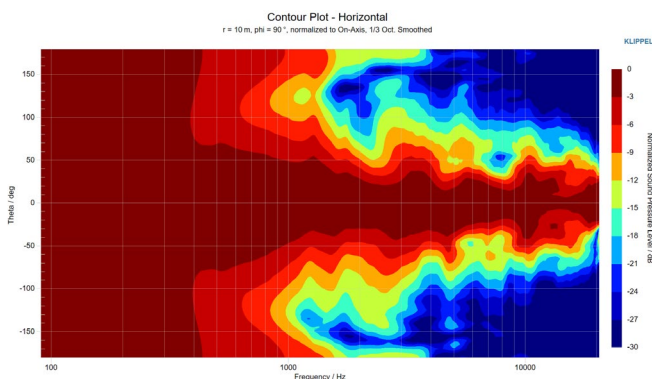

Figure 3.1: Horizontal directivity isobars

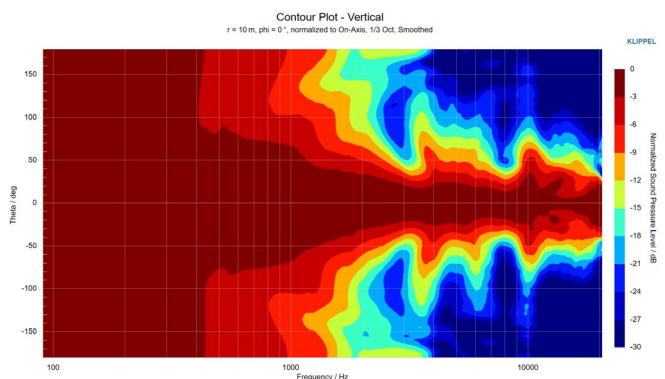

Figure 3.2: Vertical directivity isobars

### 3.5 Cyclone 4 Dimensions

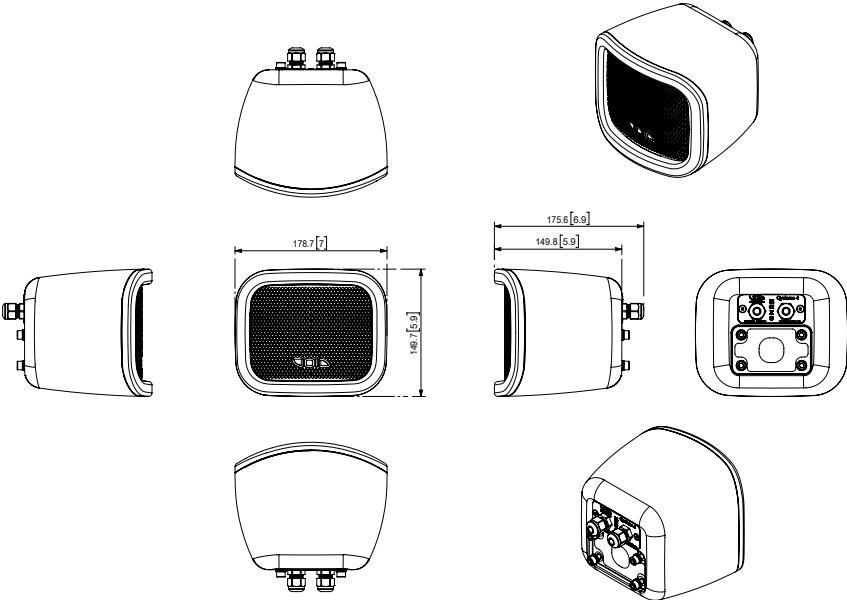

Figure 3.3: Dimensions

# 4 Cable and Wiring

## 4.1 Electrical safety



To avoid electrical hazards please note the following:

- Do not access the inside of any electrical equipment. Refer servicing to Void-approved service agents.

## 4.2 Cable considerations for fixed installations

We recommend specifying installation-grade Low Smoke Zero Halogen (LSZH) cables for permanent installations. The cables should use Oxygen Free Copper (OFC) of grade C11000 or above. Cables for permanent installations should be compliant with the following standards:

- IEC 60332.1 Fire retardancy of a single cable
- IEC 60332.3C Fire retardancy of bunched cables
- IEC 60754.1 Amount of Halogen Gas Emissions
- IEC 60754.2 Degree of acidity of released gases
- IEC 61034.2 Measurement of smoke density.

We suggest using the following maximum copper cable lengths to keep level losses below 0.6 dB.

Metric mm <sup>2</sup>	Imperial AWG	16 $\Omega$ load	8 $\Omega$ load	4 $\Omega$ load	2 $\Omega$ load
2.50 mm <sup>2</sup>	13 AWG	76 m	36 m	18 m	9 m
4.00 mm <sup>2</sup>	11 AWG	120 m	60 m	30 m	15 m

## 4.3 Phoenix connector polarity

Figure 4.1 shows the rear panel of a Cyclone Series loudspeaker with the polarity of the Phoenix connector labelled. When viewed from the rear the connectors are negative, positive, negative, positive, from left to right.

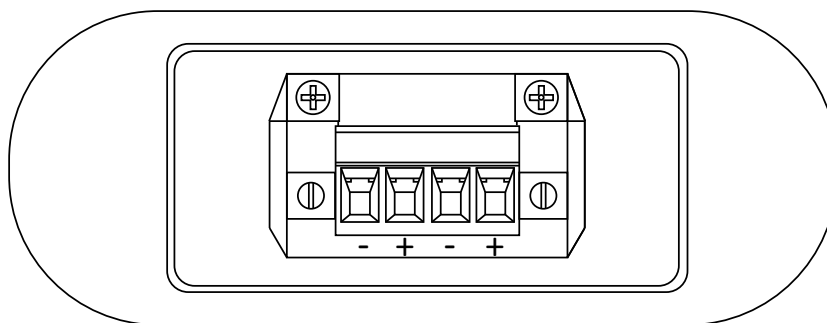
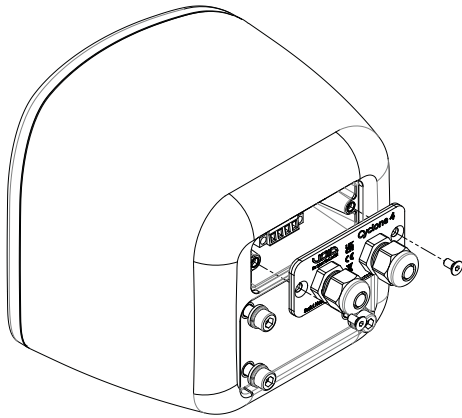

Figure 4.1: Phoenix connector diagram

# 4 Cable and Wiring

## 4.4 Cyclone glanded connector wiring



1. Remove both M4 bolts from the rear of the connector plate

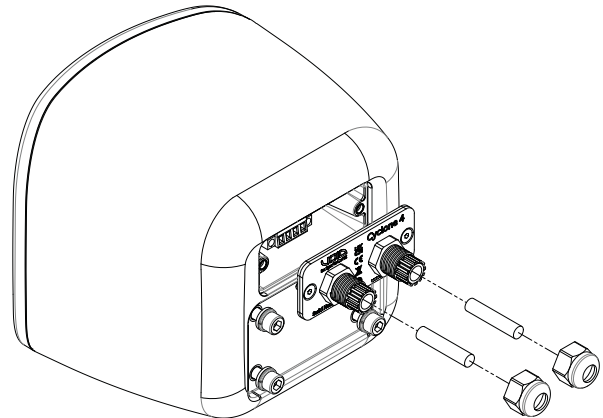

2. Undo the glanded connectors from the rear of the connector plate.

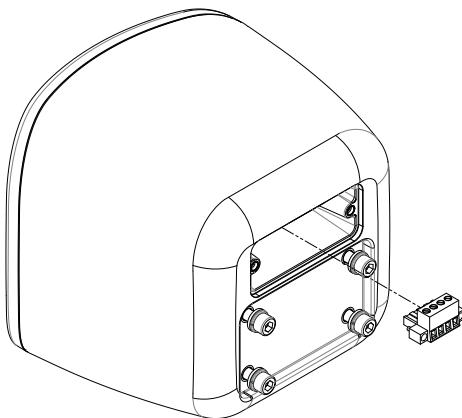

3. Remove the terminal block from the rear of the cabinet

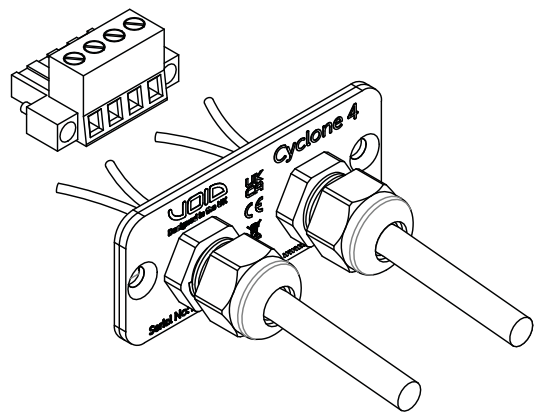

4. Insert the cables into the glands as shown and connect to the terminal block as shown in figure 4.1

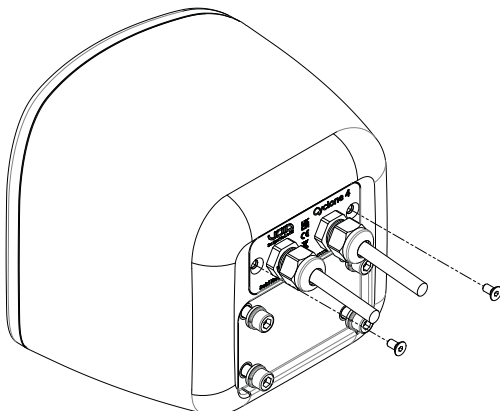

5. Reconnect the terminal block, once it is fixed in place reconnect the glanded connector plate with the M4 bolts provided

# 4 Cable and Wiring

## 4.5 Cyclone 4 wiring diagram

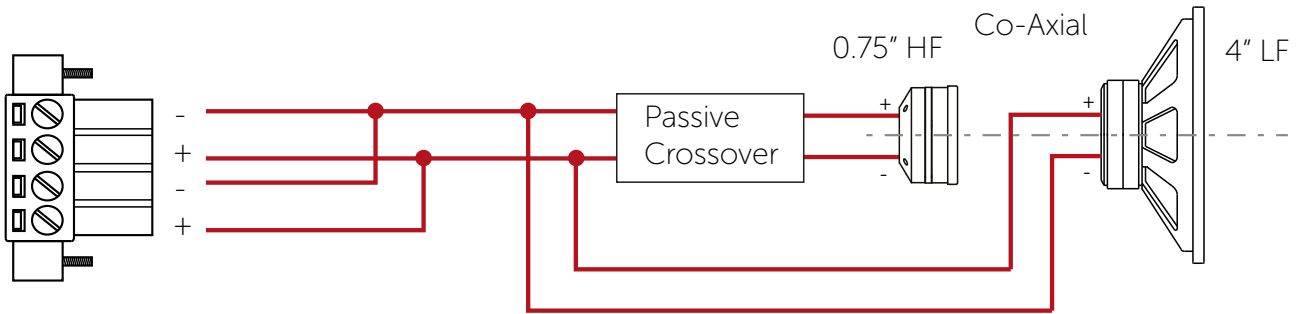

Figure 4.2: Wiring diagram

## 4.6 Bias D1/Q1/Q2 Phoenix wiring

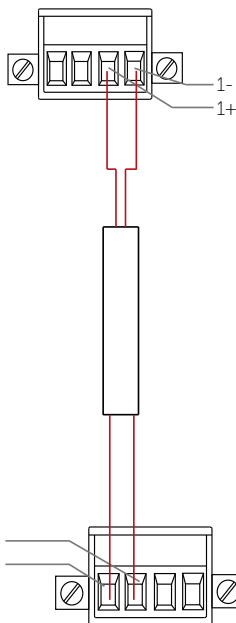
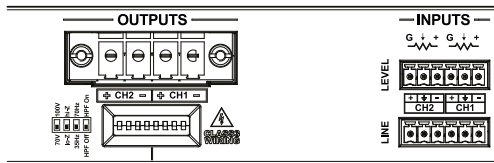

Figure 4.3: Bias D1

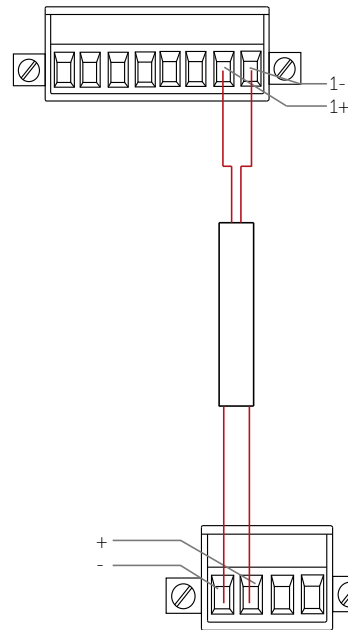
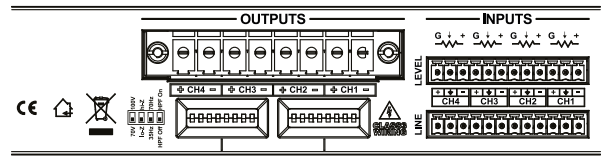

Figure 4.4: Bias Q1/Q2

Bias D1/Q1/Q2	Out 1
Output	LF (4") and HF (0.75")
Max quantity per channel	8 (2 $\Omega$ load to amplifier)

# 4 Cable and Wiring

## 4.7 Bias Q3/Q5 NL4 wiring

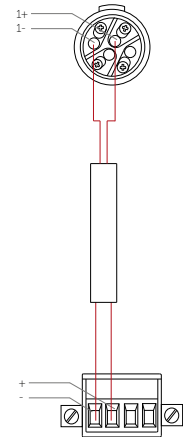
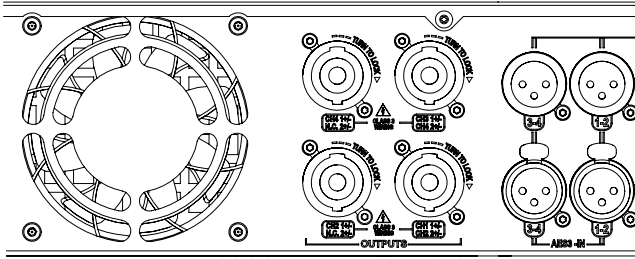

Figure 4.6: Bias Q3

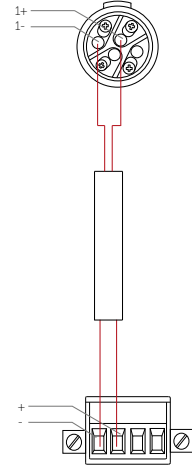
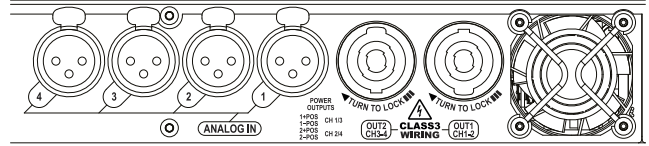

Figure 4.5: Bias Q5

Bias Q3/Q5	Out 1
Output	LF (4") and HF (0.75")
Max quantity per channel	8 (2 $\Omega$ load to amplifier)

# 5 Mounting

## Tools required

- 19 mm ratchet spanner/wrench
- 4 mm Allen key
- 5 mm Allen key

### 5.1 Installation safety



To avoid mechanical hazards, please note the following:

- Safety regulations vary in different regions. Full compliance with those regulations must be your priority
- Installations must only be undertaken by fully qualified and experienced engineers/technicians who understand local regulations
- This may include consulting a structural engineer before installation of wall brackets
- Remember that all personnel have a duty of care to themselves, to their assistants, to the venue staff and to the public
- Before lifting any part of the system above head height, check the whole rig for loose tools or other items that may fall and cause injury
- Do not use a telephone (even if hands-free) whilst installing. Always concentrate fully on the installation operation
- Do not install equipment that is worn, damaged, corroded, mishandled or over-stressed in any way
- Use only Void-approved mounting equipment and accessories
- Secondary safeties should be provided in all instances where cabinets are flying or fixing overhead and should conform to local regulations

# 5.2 Wall Mounting

Parts required:

4mm Allen key

5mm Allen key

T51 - Wall Bracket	White - IT2992
	Black - IT3031

Note: T51 Wall Bracket is included with each product

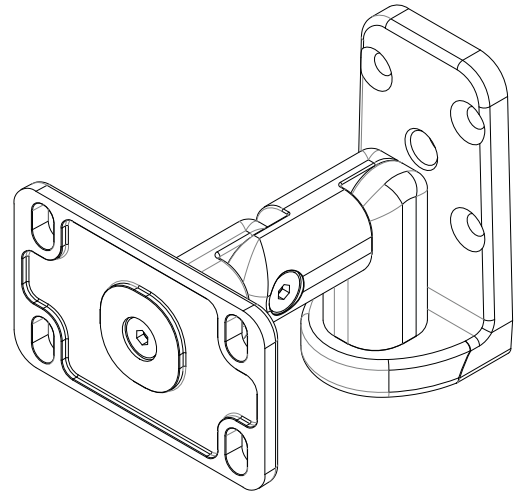

Figure 5.1: T51 Wall Bracket

Step 1:  
Remove all four M6 bolts from the rear of the loudspeaker.

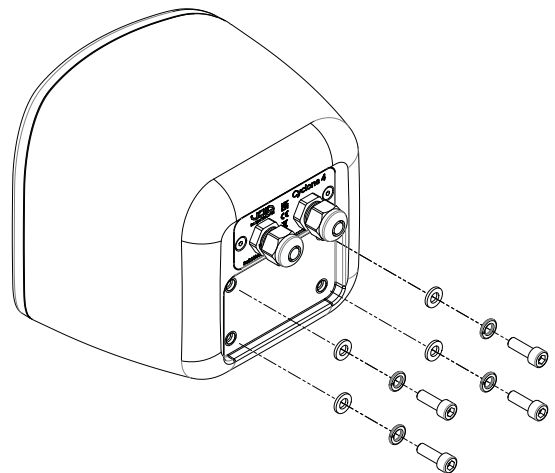

Figure 5.2: Cyclone 4 bolt removal

Step 2:  
Remove the mounting plate from the wall bracket by removing the M6 countersink as shown.

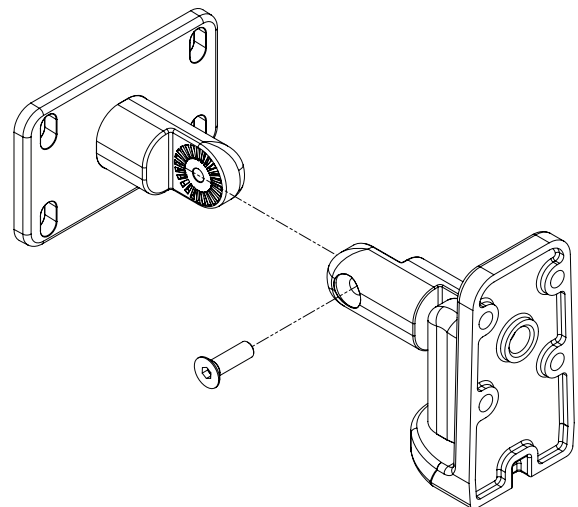

Figure 5.3: Mounting plate

## 5.2 Wall Mounting

Step 4:  
Fit the mounting plate to the rear of the Cyclone 4 with the bolts provided.

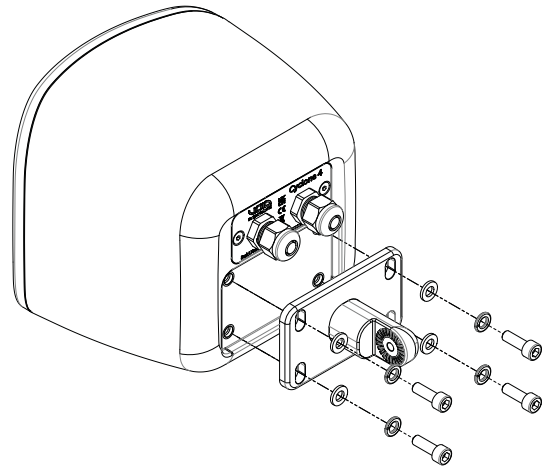

Figure 5.4: Attach plate

Step 5:  
Fix the bracket to the wall in compliance with local regulations. Once it is secure lift the Cyclone 4 with the mounting plate fixed to it into position and fix it to the bracket using the M6 countersink bolt that was removed in step 2.

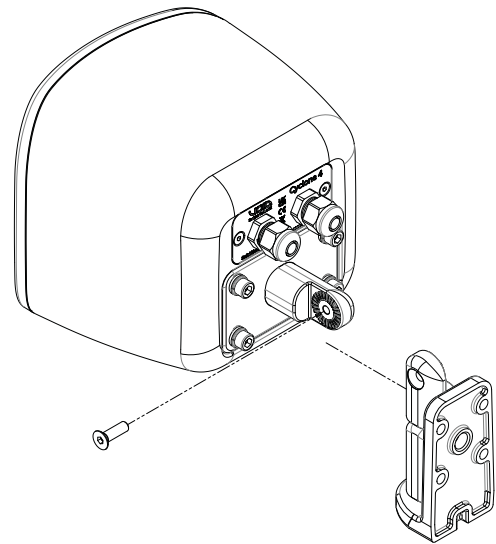

Figure 5.5: Wall mounting

Step 6a:  
When adjusting the Cyclone 4 into position if the intention is to have as close to the wall as possible then adjust the bracket to the configuration shown in figure 5.6a.

Max horizontal rotation:  $\pm 40^\circ$   
Max vertical rotation:  $+35^\circ, -0^\circ$

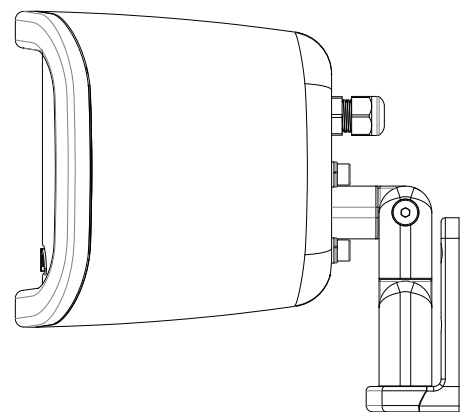

Figure 5.6a: Bracket adjustment

## 5.2 Wall Mounting

Step 6b:

When adjusting the Cyclone 4 into position if the intention is to have maximum horizontal rotation then use adjust the bracket to the configuration shown in figure 5.6b.

Max horizontal rotation:  $\pm 70^\circ$

Max vertical rotation:  $+54^\circ, -80^\circ$

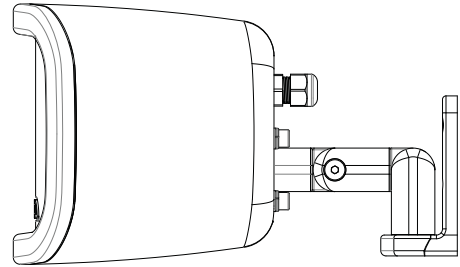

Figure 5.6b: Bracket adjustment

# 5.3 Ceiling Mounting

Part required:

T51 - Ceiling Bracket	White - IT3802
	Black - IT3354

4 mm Allen key  
5mm Allen key  
19 mm spanner

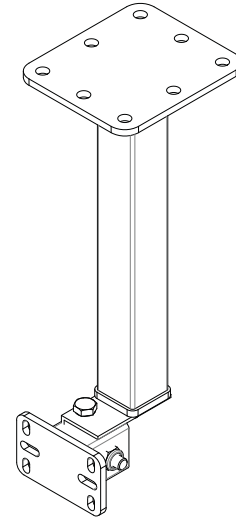

Figure 5.7: T51 ceiling bracket

Step 1:  
Remove the mounting plate from the bracket by removing the M12 bolt as shown

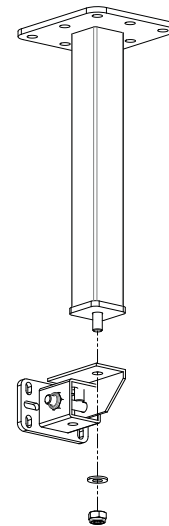

Figure 5.8: Mounting plate removal

Step 2:  
Remove all four M6 bolts from the rear of the loudspeaker.

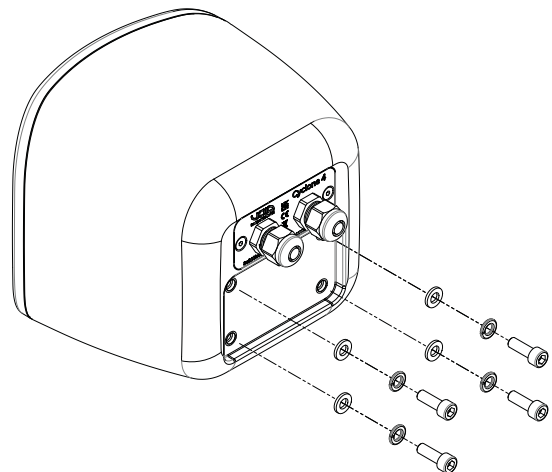

Figure 5.9: Bolt removal

## 5.3 Ceiling Mounting

Step 3:

Attach the mounting bracket to the rear of the loudspeaker using all four M6 bolts

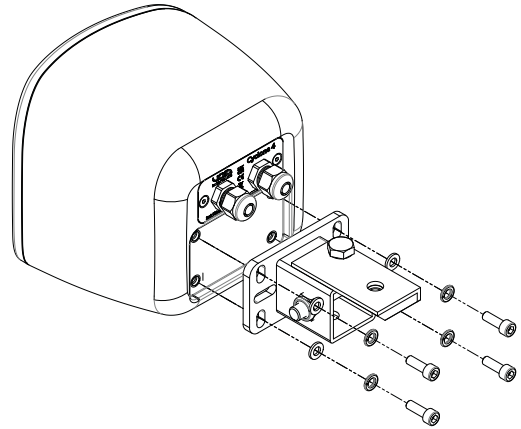

Figure 5.10: Mounting plate

Step 4:

Fix the bracket to the ceiling using all eight bolts. Once it is secure lift the Cyclone 4 with the mounting plate fixed to it into position and fix it to the bracket using the M12 nut that was removed in step 1.

Max horizontal rotation: 360°

Max vertical rotation: +10°, -12°

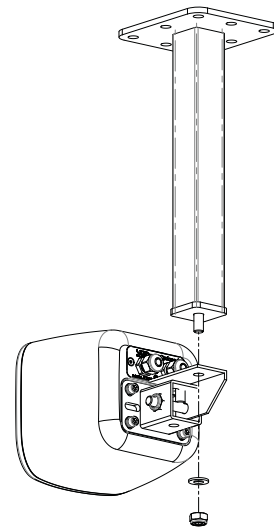

Figure 5.11: Ceiling mounting

# 5.4 Stud Mount

Part required:

5 mm Allen key

T51 - Stud Bracket	Black - IT3438
	White - IT3439

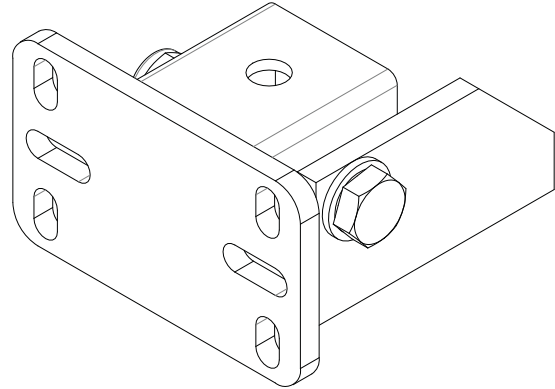

Figure 5.12: T51 stud bracket

Step 1:  
Remove all four M6 bolts from the rear of the loudspeaker.

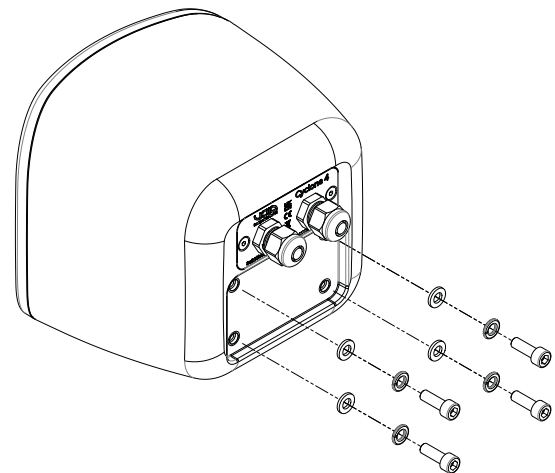

Figure 5.13: Bolt removal

Step 2:  
Attach the stud bracket using all four M6 bolts.  
The product can now be mounted to third party hardware using the M12 mounting position.

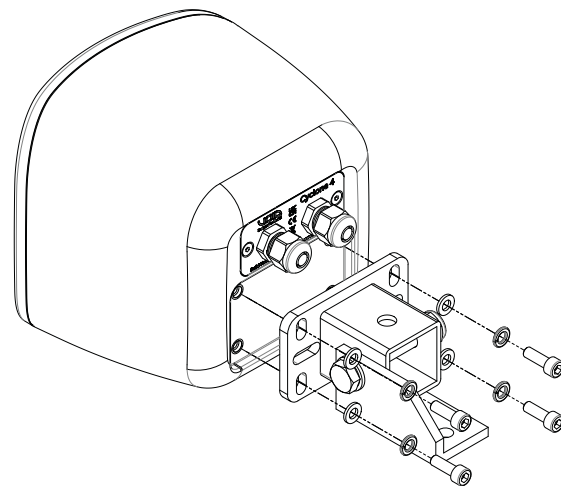

Figure 5.14: Stud bracket attachment

# 5.5 Pole Mount

Part required:

5 mm Allen key

T51 - Pole Bracket	Black - IT3727
	White - IT3728

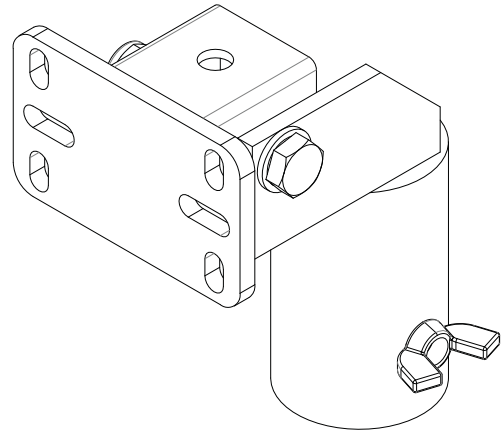

Figure 5.15: T51 pole bracket kit

Step 1:  
Remove all four M6 bolts from the rear of the loudspeaker.

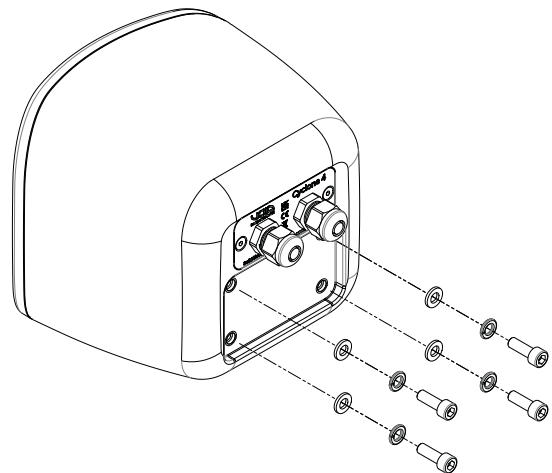

Figure 5.16: Bolt removal

Step 2:  
Attach the pole bracket kit using all four M6 bolts.

Max horizontal rotation: 360°  
Max vertical rotation: +12°, -10°

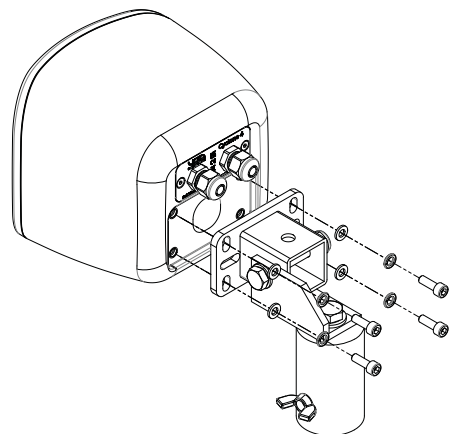

Figure 5.17: Pole mount kit attachment

# 6 Service

Void Cyclone 4 loudspeakers should only be serviced by a fully-trained technician.



No user serviceable parts inside. Refer servicing to your dealer.

## 6.1 Return authorisation

Before returning your faulty product for repair, please remember to get an R.A.N. (Return Authorisation Number) from the Void dealer who supplied the system to you. Your dealer will handle the necessary paperwork and repair. Failure to go through this return authorisation procedure could delay the repair of your product.

Note that your dealer will need to see a copy of your sales receipt as proof of purchase so please have this to hand when applying for return authorisation.

## 6.2 Shipping and packing considerations

- When sending a Void Cyclone 4 loudspeaker to an authorised service centre, please write a detailed description of the fault and list any other equipment used in conjunction with the faulty product.
- Accessories will not be required. Do not send the instruction manual, cables or any other hardware unless your dealer asks you to.
- Pack your unit in the original factory packaging if possible. Include a note of the fault description with the product. Do not send it separately.
- Ensure safe transportation of your unit to the authorised service centre.

# 7 Appendix

## 7.1 Application Note: Loudspeakers in Corrosive Environments

Void Acoustics' weather protected and IP rated products are suitable for outdoor use, however installations in highly corrosive environments, such as high salinity or in the presence of corrosive chemicals such as chlorine, require additional care and maintenance. The following guide will help to prevent corrosion and prolong both the product aesthetics and sonic performance. It is recommended that this process is implemented weekly.

Step 1: Remove the grill as applicable and wash with deionised water, ensuring all build-up of contamination is removed completely from the grille and the foam (where fitted). Allow the foam to dry completely before reinstalling, protecting the loudspeaker accordingly in the interim.

Step 2: Using a clean microfibre cloth and deionised water, use circular motions working from the top of the product down to remove contamination. Dry the product with a clean, dry microfibre cloth.

Step 3: Use a soft bristled brush and deionised water to clean the bracketry, ensuring all contamination is removed completely.

# 7 Appendix

## 7.2 Architectural Specifications

The loudspeaker shall be a passive two-way system consisting of one 4" (102 mm) direct radiating reflex loaded low frequency (LF) transducer and one 3/4" (25 mm) diameter co-axial soft dome tweeter high frequency (HF) transducer. The co-axial transducer shall be constructed on a cast aluminium frame, with the low frequency transducer consisting of a polypropylene LF cone with its dust cap removed and a 25.5 mm (1") voice coil, wound with copper wire on a high quality Kapton voice coil former, for high power handling and long-term reliability. The high frequency soft dome transducer shall be bolted through the rear of the magnet structure belonging to the low frequency transducer to form a coaxial drive unit. The sound will project through the centre of the low frequency transducer and uses the 102 mm (4") baffle diameter to achieve pattern control and low distortion.

Performance specifications for a typical production unit shall be as follows: the usable on-axis bandwidth shall be 85 Hz to 17.8 kHz (-10 dB IEC 60268-5) and shall average 80° directivity pattern in the horizontal axis and 80° in the vertical one (-6 dB down from on-axis level) from 1 kHz to 12 kHz; maximum SPL of 107 dB peak measured at 1 m using IEC268-5 pink noise. Power handling shall be 30 W AES at a rated impedance of 16 Ω.

The wiring connection shall be via a single removable lockable wiring connector with four screw-down terminals (one pair for input and one pair for loop-out to another loudspeaker) to provide secure wiring and to allow for pre-wiring of the connector before the installation. This connector should then screw lock to the enclosure to ensure secure attachment. The enclosure, of any RAL colour, shall be of an injection moulded ABS construction with a smooth cellulose finish and shall include integral threaded inserts for the fitment of wall and ceiling mounting hardware. The external dimensions of the cabinet shall be (H) 150 mm x (W) 179 mm x (D) 175 mm (5.9" x 7.1" x 6.9"). Weight shall be 1.3 kg (2.7 lbs).

The loudspeaker shall be the Void Acoustics Cyclone 4.

## 7.3 Changelog

Document Version	Notes	Valid for S.N
UG10567-1.3	Updated specs to IEC 60268-5	C4YXXXX - Current

## NORTH AMERICA

Void Acoustics North America

Call: +1 (630) 686 6616

Email: [sales.usa@voidacoustics.com](mailto:sales.usa@voidacoustics.com)

## HEAD OFFICE

Void Acoustics Research Ltd

Unit L, The Fulcrum

Vantage Way

Poole

BH12 4NU

United Kingdom

Call: +44(0) 1202 666006

Email: [hello@voidacoustics.com](mailto:hello@voidacoustics.com)



Hear. Feel. Connect.

[voidacoustics.com](http://voidacoustics.com)