

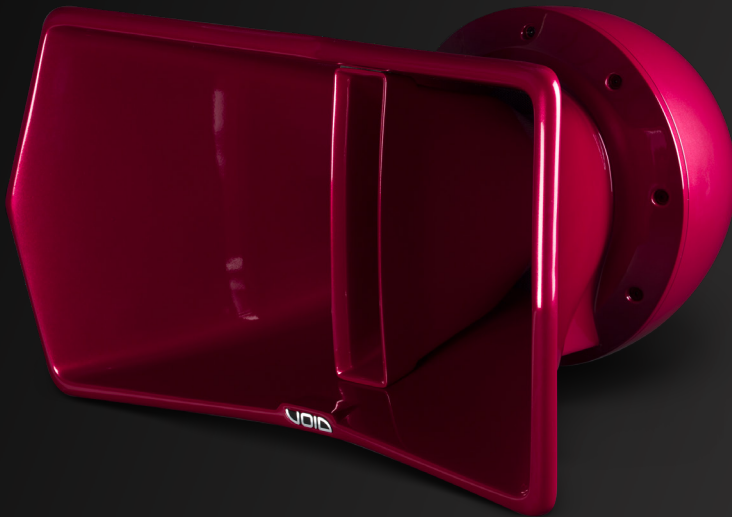

Hear. Feel. Connect.

voidacoustics.com



Air Vantage

Breathtaking performance, exceptional design

USER GUIDE V2.1

©2026 Void Acoustics Research Ltd.

This user guide is subject to change without notice.
For the latest online version, visit: www.voidacoustics.com

Void Acoustics and the Void logo are registered trademarks of Void Acoustics Research Ltd. in the United Kingdom, USA and other countries; all other Void trademarks are the property of Void Acoustics Research Ltd.

Contents

1	Safety and regulations	4
1.1	Important safety instructions	4
1.2	Limitations	4
1.3	EC declaration of conformity	4
1.4	UKCA Conformity	4
1.5	Warranty Statement	4
1.6	WEEE directive	4
2	Unpacking and Checking	5
3	About	6
3.1	Welcome	6
3.2	Air Vantage overview	6
3.3	Key features	6
3.4	Air Vantage specifications	7
3.5	Air Vantage dimensions	8
4	Cable and Wiring	9
4.1	Electrical safety	9
4.2	Cable considerations for fixed installations	9
4.3	Air Vantage wiring diagram	9
4.4	Bias D1/Q1/Q2 Phoenix wiring	10
4.5	Bias Q3/Q5 4-pin locking connector wiring	10
5	Mounting	11
5.1	Installation safety	11
5.2	Air Vantage pole mounting	12
5.3	Stud bracket mounting	14
5.4	Wall mounting	16
5.5	Ceiling pole mounting	18
5.6	Pole mounting on U bracket	20
5.7	Truss mounting	22
6	Service	24
6.1	Return Authorisation	24
6.2	Shipping and packing considerations	24
7	Appendix	25
7.1	Architectural Specifications	25
7.2	Changelog	25

1 Safety and Regulations

1.1 Important safety instructions



The lightning flash with an arrowhead symbol within an equilateral triangle is intended to alert the user to the presence of uninsulated "dangerous voltage" within the product's enclosure that may be of sufficient magnitude to constitute a risk of electric shock to persons.



The exclamation point within an equilateral triangle is intended to alert the user of the presence of important operating and maintenance (servicing) instructions in the literature accompanying the appliance.

Safety instructions - read this first

1. Read these instructions.
2. Keep these instructions.
3. Heed all warnings.
4. Follow all instructions.
5. Do not use this apparatus near water.
6. Clean only with a dry cloth.
7. Do not block any ventilation openings. Install in accordance with the manufacturer's instructions.
8. Do not install near any heat source such as radiators, heat registers, stoves, or other such apparatus that produce heat.
9. Do not defeat the safety purpose of the grounding-type plug. A grounding type plug has two blades and a third grounding prong. The third prong is provided for your safety. If the provided plug does not fit into your outlet, consult an electrician for replacement of the obsolete outlet.
10. Protect power cords from being walked on or pinched particularly at plugs, convenience receptacles, and the point where they exit the apparatus.
11. Only use attachments and accessories specified by Void Acoustics.
12. Only use with the cart, stand, tripod, bracket, or table specified by the manufacturer, or sold with the apparatus. When a cart is used, use caution when moving the cart/apparatus combination to avoid injury from tip-over.
13. Unplug the apparatus during lightning storms or when unused for long periods of time.
14. Refer all servicing to qualified service personnel. Servicing is required when the apparatus has been damaged in any way, such as when the power-supply cord or plug is damaged, liquid has been spilled or objects have fallen into the apparatus, the apparatus has been exposed to rain or moisture, does not operate normally, or has been dropped.
15. Since the mains power supply cord attachment plug is used to disconnect the device, the plug should always be easily accessible.
16. Void loudspeakers can produce sound levels capable of causing permanent hearing damage from prolonged exposure. The higher the sound level, the less exposure needed to cause such damage. Avoid prolonged exposure to the high sound levels from the loudspeaker.

1.2 Limitations

This guide is provided to help familiarise the user with the loudspeaker system and its accessories. It is not intended to provide comprehensive electrical, fire, mechanical and noise training and is not a substitute for industry-approved training. Nor does this guide absolve the user of their obligation to comply with all relevant safety legislation and codes of practice. While every care has been taken in creating this guide, safety is user-dependent and Void Acoustics Research Ltd cannot guarantee complete safety whenever the system is rigged and operated.

1.3 EC declaration of conformity

For EC Declaration of Conformity please go to:

www.voidacoustics.com/eu-declaration-loudspeakers

1.4 UKCA marking

For details of the UKCA marking go to:

www.voidacoustics.com/uk-declaration-loudspeakers

1.5 Warranty statement

For warranty statement go to:

<https://voidacoustics.com/terms-conditions/>

1.6 WEEE directive

If the time arises to throw away your product, please recycle all the components possible.



This symbol indicates that when the end-user wishes to discard this product, it must be sent to separate collection facilities for recovery and recycling. By separating this product from other household-type waste, the volume of waste sent to incinerators or land-fills will be reduced and natural resources will thus be conserved.

The Waste Electrical and Electronic Equipment Directive (WEEE Directive) aims to minimise the impact of electrical and electronic goods on the environment. Void Acoustics Research Ltd complies with the Directive 2002/96/EC and 2003/108/EC of the European Parliament on waste electrical and electronic equipment (WEEE) in order to reduce the amount of WEEE that is being disposed of in land-fill sites. All of our products are marked with the WEEE symbol; this indicates that this product must NOT be disposed of with other waste. Instead it is the user's responsibility to dispose of their waste electrical and electronic equipment by handing it over to an approved reprocessor, or by returning it to Void Acoustics Research Ltd for reprocessing. For more information about where you can send your waste equipment for recycling, please contact Void Acoustics Research Ltd or one of your local distributors.



2 Unpacking and Checking

All Void Acoustics products are carefully manufactured and thoroughly tested before being despatched. Your dealer will ensure that your Void products are in pristine condition before being forwarded to you but mistakes and accidents can happen.

Before signing for your delivery:

- Inspect your shipment for any signs of contamination, abuse or transit damage as soon as you receive it
- Check your Void Acoustics delivery fully against your order
- If your shipment is incomplete or any of its contents are found to be damaged; inform the shipping company and inform your dealer.

Air Vantage loudspeakers are heavy (23.5 kg/51.8 lbs) and require a minimum two people to lift.

- Undo the four butterfly catches on the transport case then remove the lid making sure the lid is clear before moving sideways
- If you need to place the Air Vantage on a flat surface ensure you use a lint free product to protect the finish
- To remove from the transport case, each person should hold the Air Vantage on each side, with one hand on the edge of the horn flare, and the other supporting the weight of the drivers to the rear as shown in figure 2.1
- When removing the Air Vantage take care not to foul on the lower tray of the transport case.

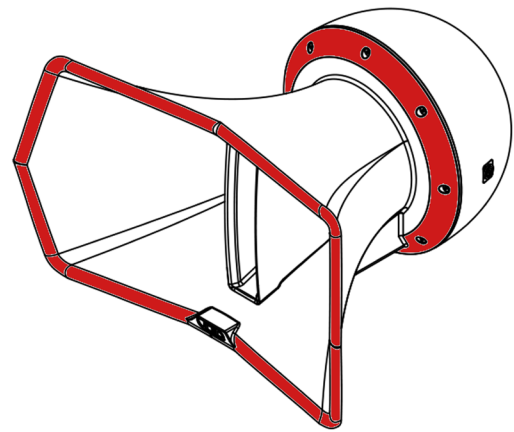

Figure 2.1: Safe Handling Positions
(as indicated in red)

Keep the original packaging in case you need to return a product for service later.

See section 1.5 for registration and warranty conditions and see section 6 if your product needs service.

3 About

3.1 Welcome

Many thanks for purchasing this Void Acoustics Air Vantage. We truly appreciate your support. At Void, we design, manufacture and distribute advanced professional audio systems for the installed and live sound market sectors. Like all Void products, our highly skilled and experienced engineers have successfully combined pioneering technologies with ground-breaking design aesthetics, to bring you superior sound quality and visual innovation. In buying this product, you are now part of the Void family and we hope using it brings you years of satisfaction. This guide will help you both use this product safely and ensure it performs to its full capability.

3.2 Air Vantage overview

Use the Air Vantage as a stand-alone mid-top with low frequency enclosures in a main club system, or as a DJ monitor when paired with the Sub Vantage. True point source transmission, a linear frequency response, and very high SPL with minimum fatigue are just some of its benefits.

3.3 Key features

- Horn loaded 12 inch coaxial loudspeaker
- High-sensitivity, high-output design
- FEA optimised waveguide for pattern control at lower frequencies
- Controlled 70° x 40° dispersion for consistent coverage
- Low-resonance fibreglass composite construction
- Visually striking appearance
- T75-style fixing points for compatibility with a wide range of mounting options
- FIR optimised preset with Void amplifiers
- Available as standard in red with a black grille, black with a black grille, and white with a white grille. Custom RAL and KROME finishes are available upon request

3 About

3.4 Air Vantage specifications

Frequency Response ¹	170 Hz - 20 kHz
Maximum Output ²	126 dB cont, 132 dB peak
Nominal Dispersion	70°H x 40°V
Sensitivity	100 dB 1W/1m
Driver Configuration	1 x 12" LF, 1 x 1.5" coaxial
Power Handling	500 W AES
Nominal impedance	8 Ω
Suggested Minimum Amplifier	Bias Q1.5+
Weight	23.5 kg (51.8 lbs)
Connections	2 x 4-pin locking connector
Enclosure	Fibreglass composite
Finish	Smooth cellulose
Mounting	Type 75 plate
Height	415 mm (16.3")
Width	719 mm (28.3")
Depth	660 mm (26")
Colour	Custom colours available upon request

1 -10 dB IEC 60268-5 2 Calculated 3 Measured in half space

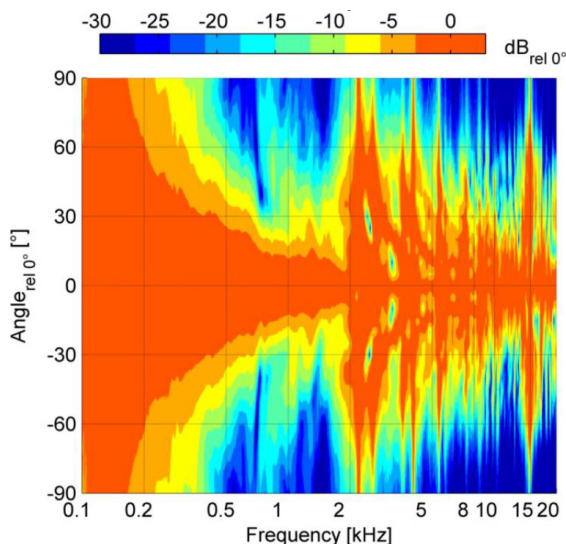

Figure 3.1: Horizontal directivity isobars

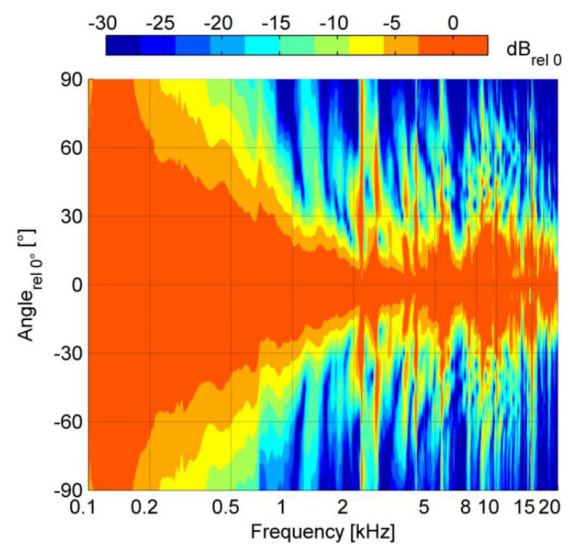

Figure 3.2: Vertical directivity isobars

3 About

3.5 Air Vantage dimensions

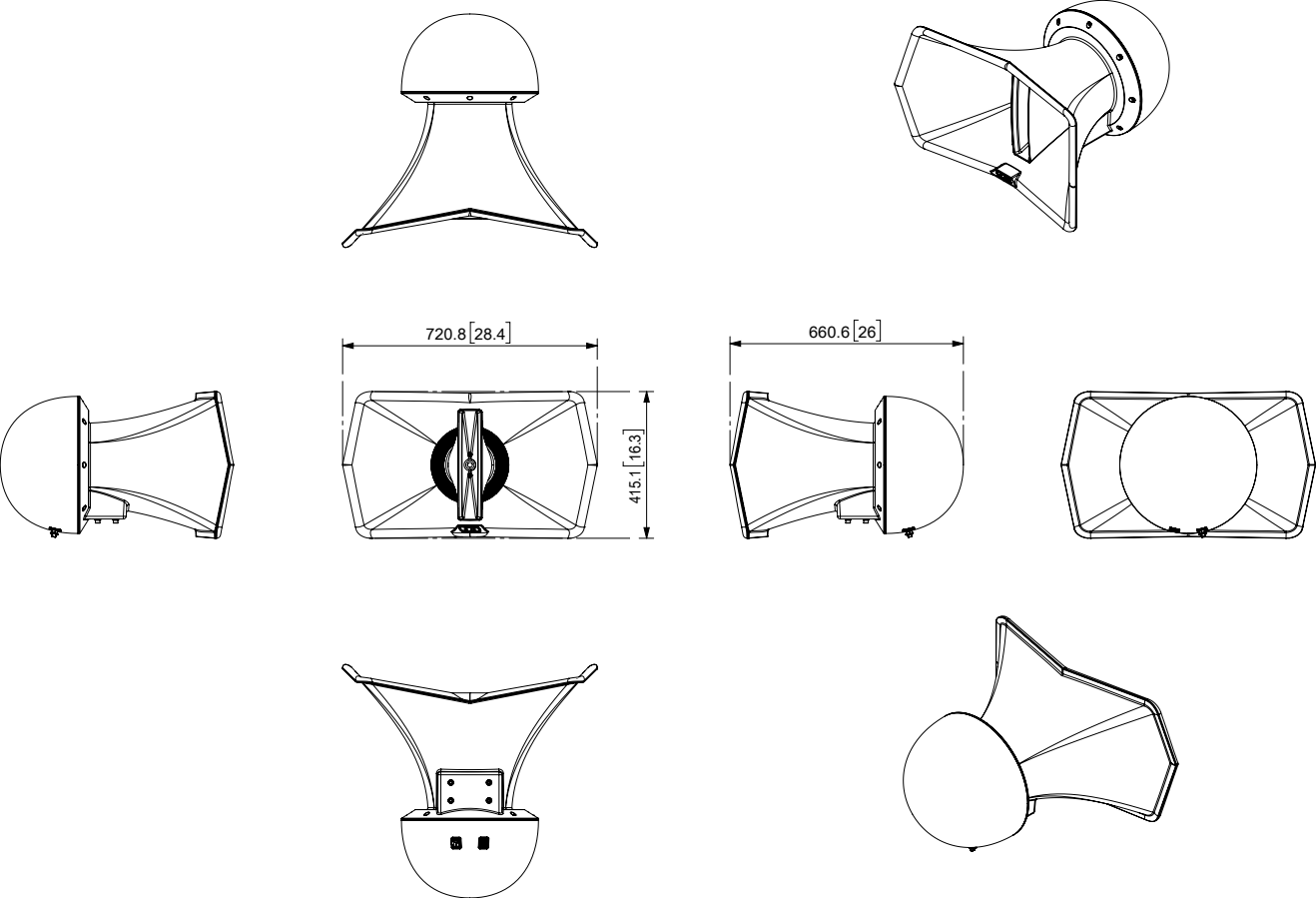

Figure 3.3: Dimensions

4 Cable and Wiring

4.1 Electrical safety



To avoid electrical hazards please note the following:

- Do not access the inside of any electrical equipment. Refer servicing to Void-approved service agents

4.2 Cable considerations for fixed installations

We recommend specifying installation-grade Low Smoke Zero Halogen (LSZH) cables for permanent installations. Cables for permanent installations should be compliant with the following standards:

- IEC 60332.1 Fire retardancy of a single cable
- IEC 60332.3C Fire retardancy of bunched cables
- IEC 60754.1 Amount of Halogen Gas Emissions
- IEC 60754.2 Degree of acidity of released gases
- IEC 61034.2 Measurement of smoke density

We suggest using the following maximum copper cable lengths to keep level losses below 0.6 dB.

Metric mm ²	Imperial AWG	8 Ω load	4 Ω load	2 Ω load
2.50 mm ²	13 AWG	36 m	18 m	9 m
4.00 mm ²	11 AWG	60 m	30 m	15 m

4.3 Air Vantage wiring diagram

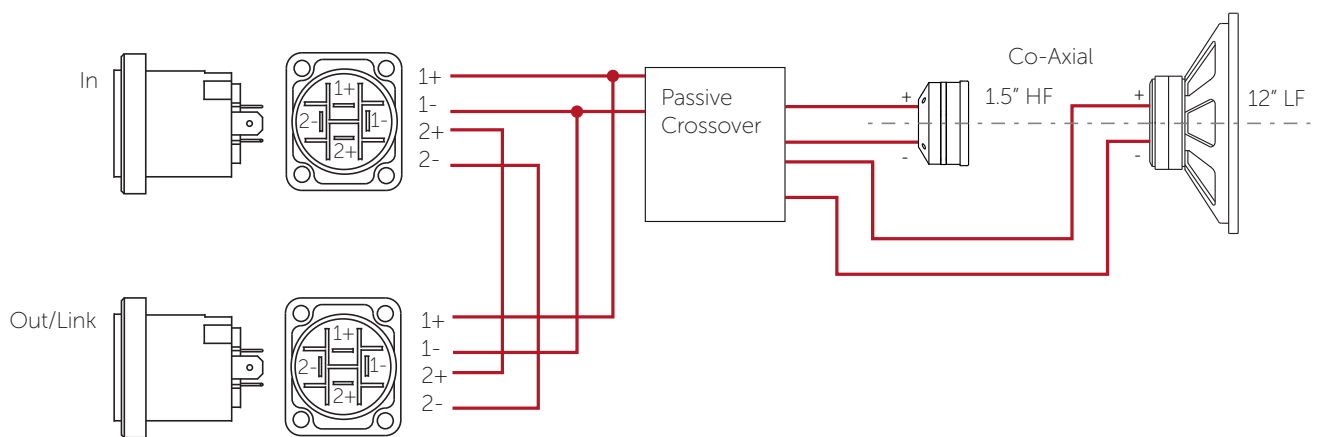

Figure 4.1: Air Vantage wiring diagram

4 Cable and Wiring

4.4 Bias D1/Q1/Q2 Phoenix wiring

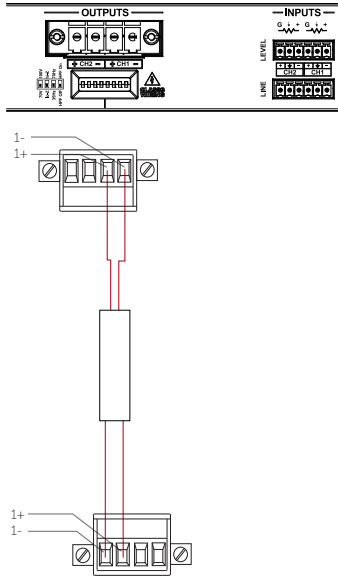

Figure 4.2: Bias D1

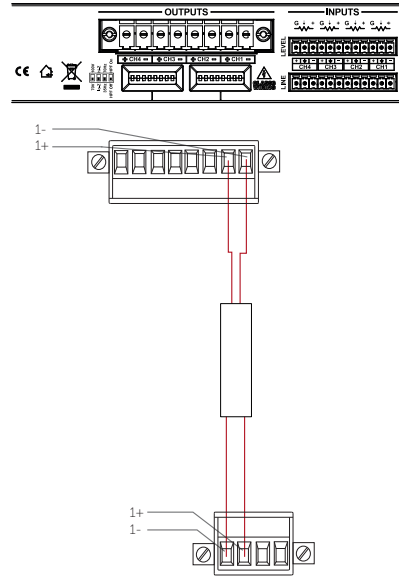

Figure 4.3: Bias Q1/Q2

Bias D1/Q1/Q2	Single channel
Output	LF (12") and HF (1.5")
Max parallel units	4 (2 Ω load to amplifier)

4.5 Bias Q3/Q5 4-pin locking connector wiring

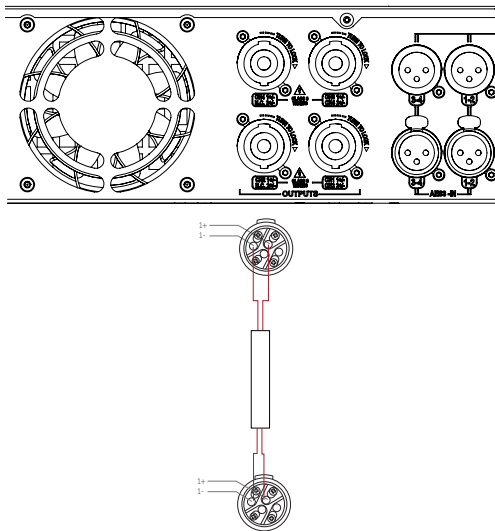

Figure 4.4: Bias Q3

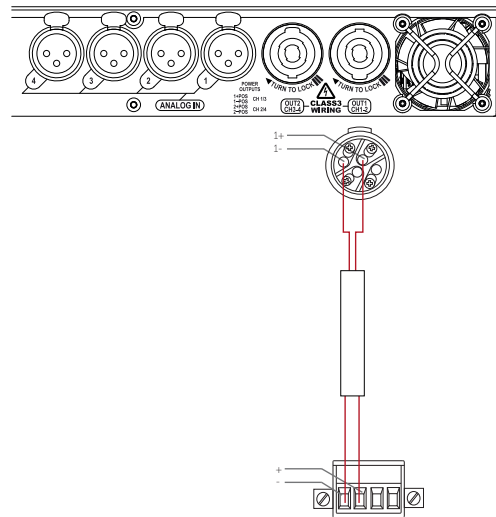

Figure 4.5: Bias Q5

Bias Q3/Q5	Single channel
Output	LF (12") and HF (1.5")
Max quantity per channel	4 (2 Ω load to amplifier)

5 Mounting

Tools Required

- 6 mm Allen key
- 19 mm ratchet spanner/wrench

5.1 Installation safety



To avoid mechanical hazards, please note the following:

- Safety regulations vary in different regions. Full compliance with those regulations must be your priority
- Installations must only be undertaken by fully qualified and experienced engineers/technicians who understand local regulations
- This may include consulting a structural engineer before installation of wall brackets
- Remember that all personnel have a duty of care to themselves, to their assistants, to the venue staff and to the public
- Before lifting any part of the system above head height, check the whole rig for loose tools or other items that may fall and cause injury
- Do not use a telephone (even if hands-free) whilst installing. Always concentrate fully on the installation operation
- Do not install equipment that is worn, damaged, corroded, mishandled or overstressed in any way
- Use only Void-approved mounting equipment and accessories
- Secondary safeties should be provided in all instances where cabinets are flying or fixing overhead and should conform to local regulations

5.2 Air Vantage Pole Mounting

Parts required:

T75 - Pole Bracket	Black - IT1099
	White - IT1102

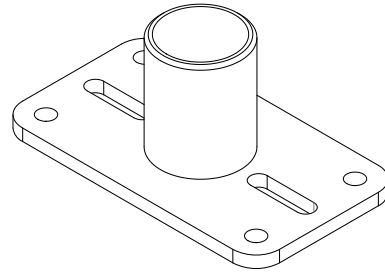

Figure 5.1: T75 - Pole Bracket

Step 1:

Lay a soft lint free rug clear of debris on the working surface to avoid damage to the loudspeaker. Place the Air Vantage with the horns face down and remove all four M8 socket cap Allen bolts.

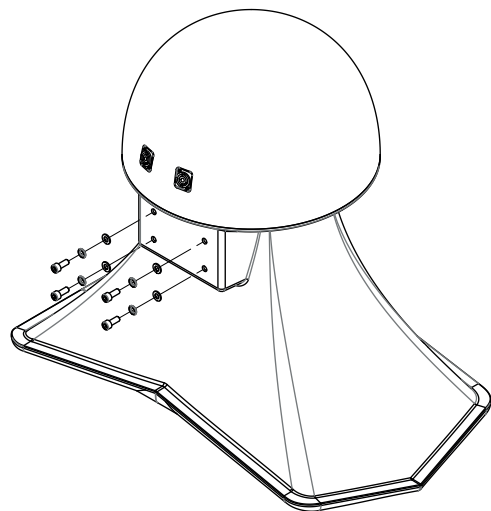

Figure 5.2: M8 socket cap removal

Step 2:

Place the T75 - Pole Bracket into position and insert the M8 socket cap Allen bolts

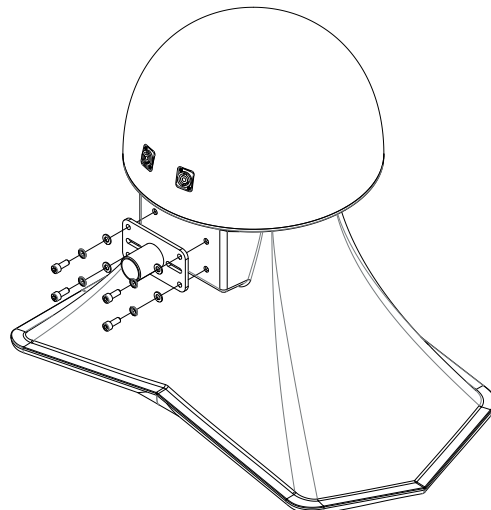

Figure 5.3: T75 - Pole Bracket positioning

5.2 Air Vantage Pole Mounting

Step 3:

Fix all four M8 socket cap Allen bolts taking care not to over tighten.

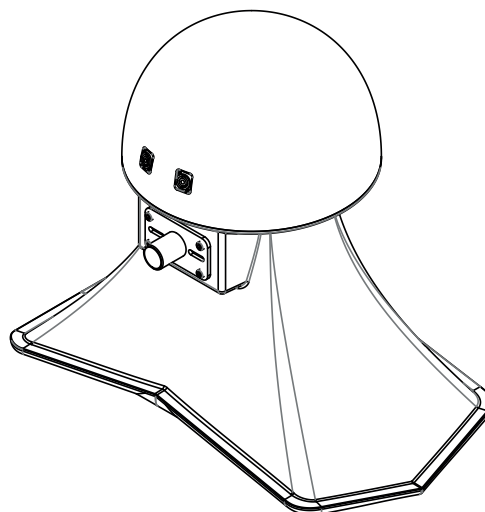

Figure 5.4: T75 - Pole Bracket fixing

Step 4:

After erecting the pole use two people to lift the Air Vantage loudspeaker into position taking care to use the safe handling positions in section 2.

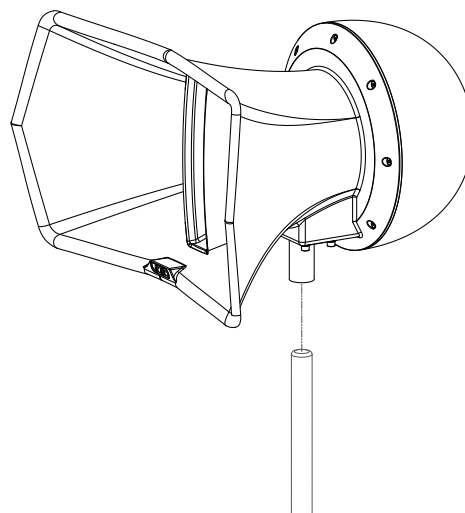

Figure 5.5: Air Vantage positioning

Step 5:

Finally ensure that the Air Vantage loudspeaker is safely in place by tightening the wingnut on the T75 pole bracket.

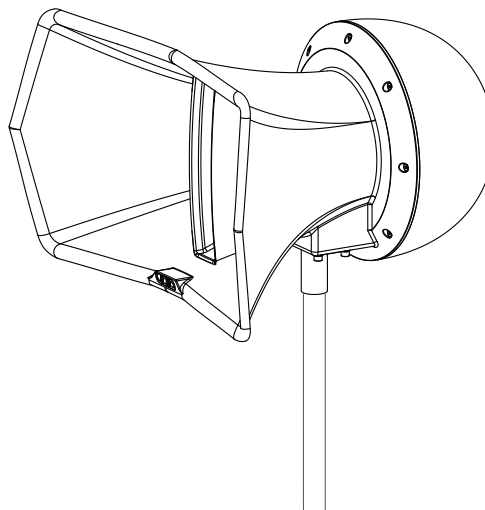

Figure 5.6: Air Vantage positioning

5.3 Stud Bracket Mounting

Parts required:

T75 - Stud Bracket	Black - IT1125
	White - IT1126

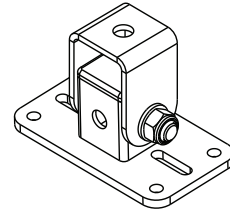

Figure 5.7: T75 - Stud Bracket

Step 1:

Lay a soft lint free rug clear of debris on the working surface to avoid damage to the loudspeaker. Place the Air Vantage with the horns face down and remove all four M8 socket cap Allen bolts.

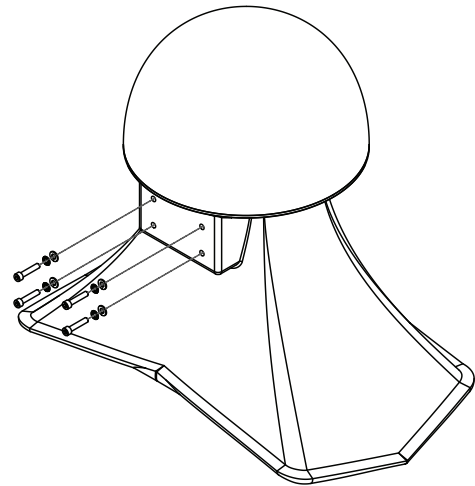

Figure 5.8: M8 socket cap removal

Step 2:

Place the T75 - Stud Bracket in position and insert the M8 socket cap Allen bolts.

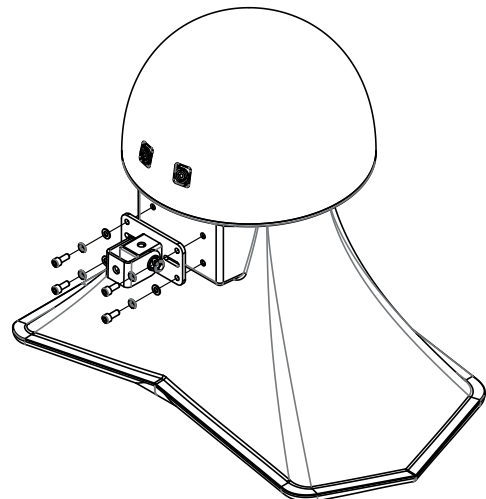

Figure 5.9: T75 - Stud Bracket positioning

5.3 Stud Bracket Mounting

Step 3:

Fix all four M8 socket cap Allen bolts taking care not to over tighten.

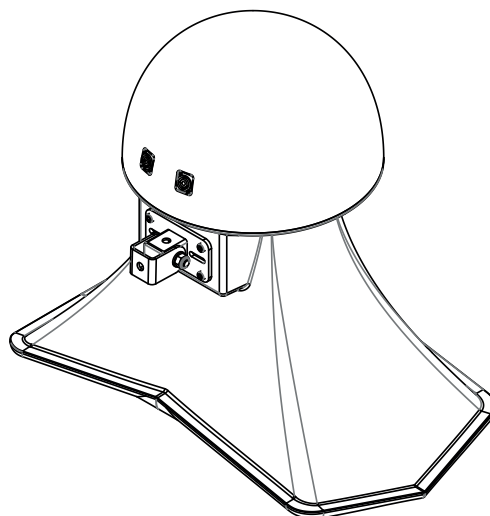

Figure 5.10: T75 - Stud Bracket fixing

5.4 Wall Mounting

Parts required:

T75 - Wall Bracket	Black - IT1132
	White - IT1133



Note:
All eight bolts must be fitted when securing the bracket to the wall.

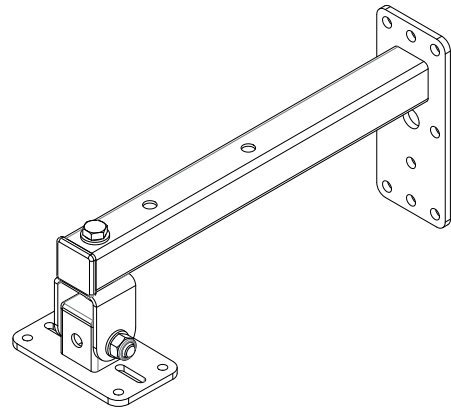

Figure 5.11: T75 - Wall Bracket with extension piece

Step 1:

Attach the extension piece to the T75 - Wall Bracket with the M12 nyloc nut.

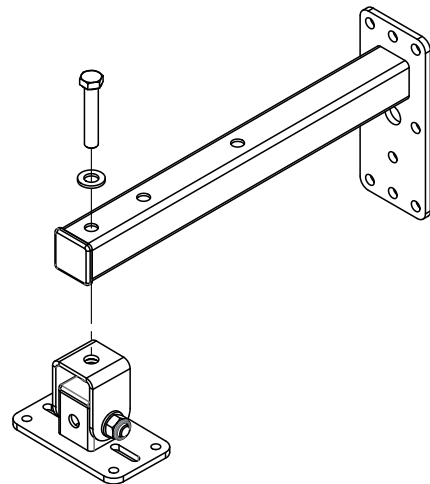

Figure 5.12: T75 - Wall Bracket with extension piece fixing

Step 2:

Raise the Air Vantage loudspeaker into position, taking care to follow the safe handling positions in section 2, and attach the M12 nyloc nut but do not tighten.

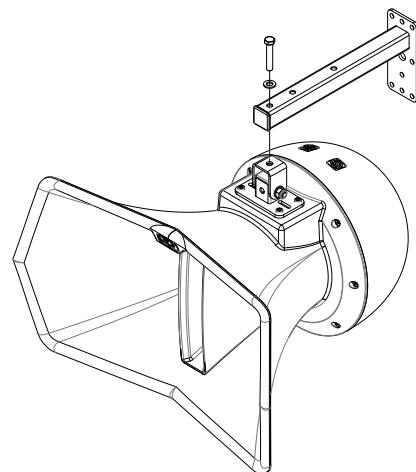

Figure 5.13: Air Vantage positioning

5.4 Wall Mounting

Step 3:

Rotate the Air Vantage loudspeaker into the desired position and tighten the M12 nyloc bolt.

Maximum rotation:
Vertical: +90°, -20°
Horizontal: $\pm 90^\circ$

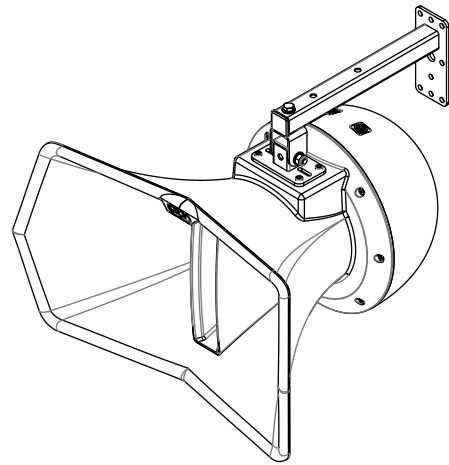

Figure 5.14: Air Vantage fixing

5.6 Ceiling Pole Mounting

Parts required:

T75 - Ceiling Bracket	500mm - Black - IT1140
	500mm - White - IT1905
	1000mm - Black - IT3217
	1000mm - White - IT3218
	1500mm - Black - IT3688



Note:
All eight bolts must be fitted when securing the bracket to the wall.

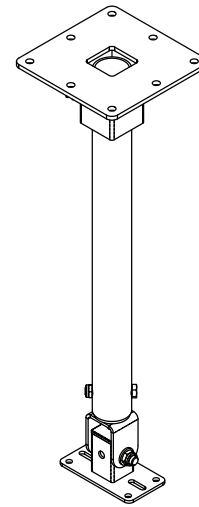

Figure 5.15: T75 - Ceiling Bracket

Step 1:

Remove the T75 stud bracket and follow the steps in section 5.3 to attach it to the Air Vantage. Lift the Air Vantage into position making sure to hold it by the safe lifting positions detailed in section 3.

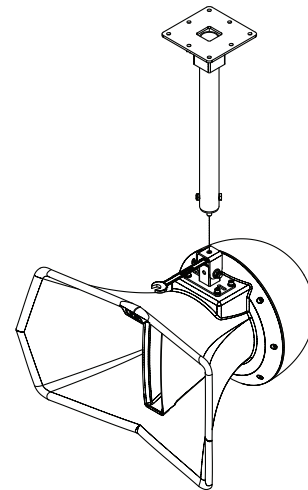

Figure 5.16: Air Vantage positioning

Step 2:

Attach the Air Vantage bracket with the M12 nyloc nut using a 19 mm ratchet spanner.

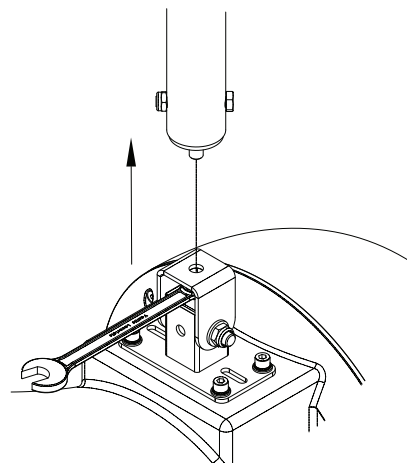

Figure 5.17: Air Vantage positioning detail

5.6 Ceiling Pole Mounting

Step 3:

Attach the secondary bond (safety wire) to the central box section.



The safety wire must be rated to 23.5 kg (51.8 lbs) with a safety factor conforming to local regulations.

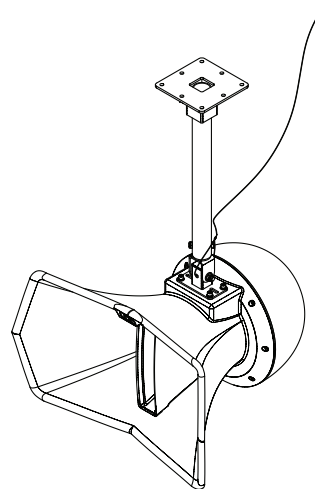

Figure 5.18: Safety wire attachment

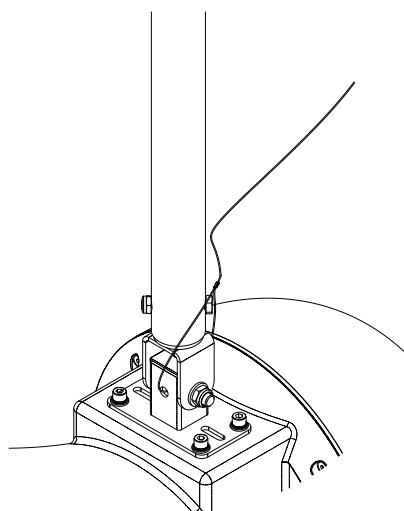

Figure 5.19: Safety wire attachment detail

5.7 Pole Mounting on T75 Stud Bracket

Parts required:

Heavy Duty Top Hat Casting	Black - IT2238
	White - IT2237

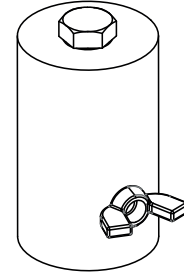

Figure 5.20: Heavy Duty Top Hat Casting

Step 1:
Remove the M12 bolt from the pole mount bracket.

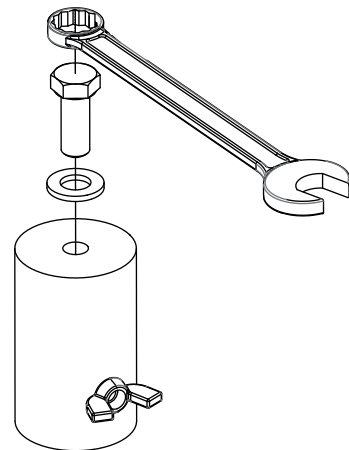

Figure 5.21: Pole mount bracket removal

Step 2:
Mount the pole mount bracket to the T75 stud bracket.

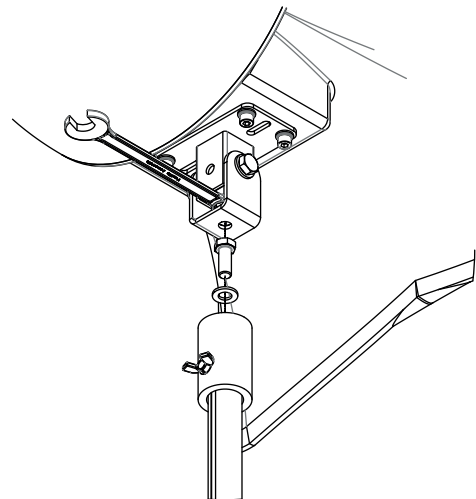

Figure 5.22: Mounting to the T75 stud bracket

5.7 Pole Mounting on T75 Stud Bracket

Step 3:

Lift the Air Vantage loudspeaker into position taking care to follow the safe handling positions detailed in section 2.

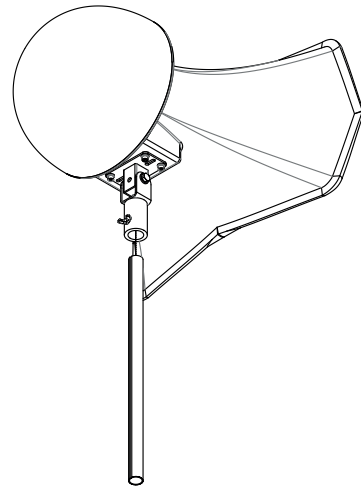

Figure 5.23: Positioning the loudspeaker

Step 4:

Adjust the loudspeaker into the desired position and then tighten the wing nut on the pole mount bracket.

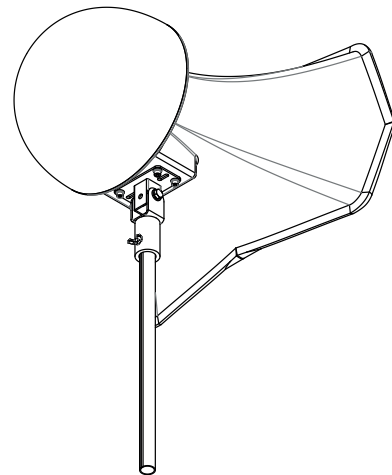

Figure 5.24: Adjusting the loudspeaker position

5.8 Truss Mounting

Parts required:

TU - Truss Bracket	Black - IT1081
	White - IT1082
T75 - Stud Bracket	Black - IT1125
	White - IT1126

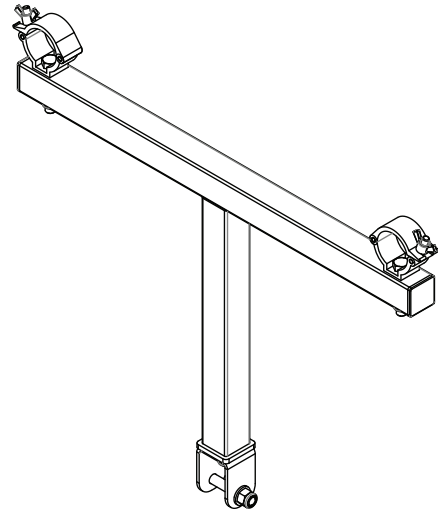

Figure 5.25: TU - Truss Bracket

Step 1:

Remove the T75 stud bracket and follow the steps in section 5.3 to attach it to the Air Vantage. Remove the wing-nuts from the couplers and position the bracket in the desired location on the truss.

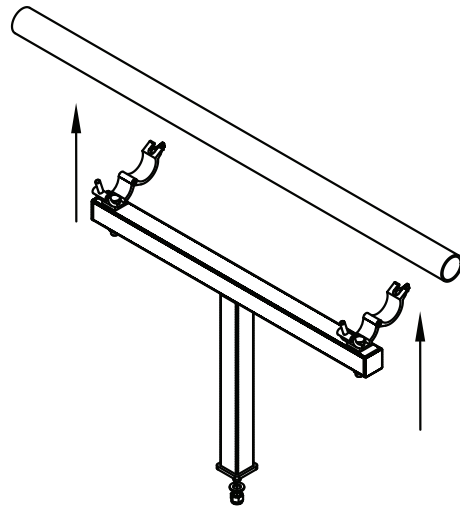

Figure 5.26: Positioning the TU - Truss Bracket

Step 2:

Tighten the wing-nuts on the couplers so that the bracket is securely fastened. Remove the M12 nyloc nut using a 19 mm ratchet spanner.

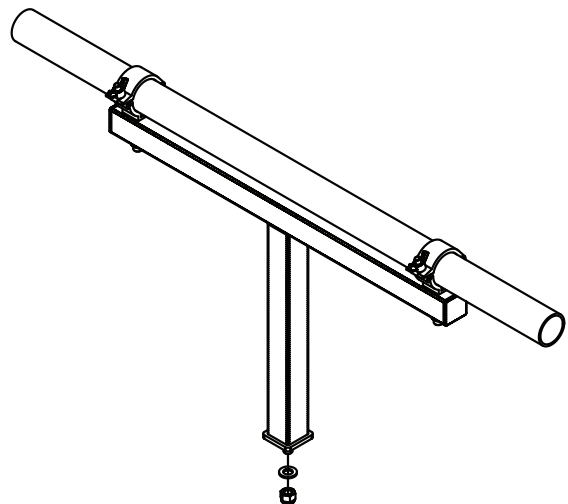

Figure 5.27: Attaching the truss bracket

5.8 Truss Mounting

Step 3:

Lift the Air Vantage into position making sure to hold it by the safe lifting positions detailed in section 2.

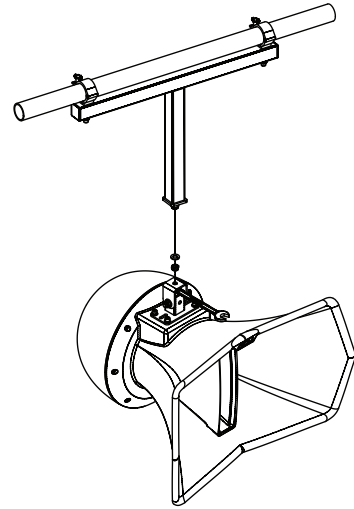

Figure 5.28: Air Vantage truss mount

Step 4:

Attach the Air Vantage the bracket with the M12 nyloc nut using a 19 mm ratchet spanner.

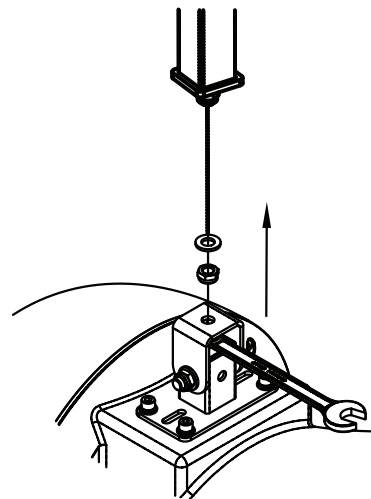

Figure 5.29: Air Vantage truss mount detail

Step 5:

Attach the secondary bond (safety wire) to the central box section.



The safety wire must be rated to 23.5 kg (51.8 lbs) with a safety factor conforming to local regulations.

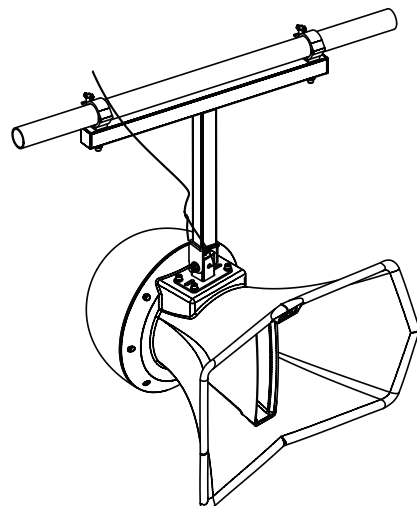

Figure 5.30: Safety wire attachment

6 Service

Void Air Vantage loudspeakers should only be serviced by a fully-trained technician.



No user serviceable parts inside. Refer servicing to your dealer.

6.1 Return authorisation

Before returning your faulty product for repair, please remember to get an R.A.N. (Return Authorisation Number) from the Void dealer who supplied the system to you. Your dealer will handle the necessary paperwork and repair. Failure to go through this return authorisation procedure could delay the repair of your product.

Note that your dealer will need to see a copy of your sales receipt as proof of purchase so please have this to hand when applying for return authorisation.

6.2 Shipping and packing considerations

- When sending a Void Air Vantage loudspeaker to an authorised service centre, please write a detailed description of the fault and list any other equipment used in conjunction with the faulty product.
- Accessories will not be required. Do not send the instruction manual, cables or any other hardware unless your dealer asks you to.
- Pack your unit in the original factory packaging if possible. Include a note of the fault description with the product. Do not send it separately.
- Ensure safe transportation of your unit to the authorised service centre.

7 Appendix

7.1 Architectural specification

The loudspeaker shall be a passive, two-way system consisting of one high power 12" (304.8 mm) horn loaded low frequency (LF) transducer and 1.5" (25 mm) exit co-axial high frequency (HF) compression driver mounted in a high precision waveguide within an aesthetically designed enclosure.

The co-axial transducer shall be constructed on a cast aluminium frame, with the low frequency transducer consisting of a treated paper cone with its dust cap removed and a 25.4 mm (1") voice coil, wound with copper wire on a high quality voice coil former, with neodymium magnets for high power handling and long-term reliability.

The high frequency transducer, which also uses neodymium magnets, shall be bolted through the rear of the magnet structure belonging to the low frequency transducer to form a co-axial drive unit. The sound will project through a machined waveguide that exits in the centre of the low frequency transducer coupling with its horn by using the 718 mm (28.3") baffle diameter of such horn to achieve greater SPL and pattern control on high frequencies.

Performance specifications for a typical production unit shall be as follows: the usable on-axis bandwidth of 170 Hz to 20 kHz (-10 dB IEC 60268-5), with an average 40° directivity pattern in the vertical axis and 70° in the horizontal one (-6 dB down from on-axis level) from 1 kHz to 12 kHz; maximum SPL of 132 dB peak (126 dB continuous) measured at 1 m using IEC268-5 pink noise. Power handling at 500 W AES at a rated impedance of 8 Ω ; crossover point at 1.6 kHz passive. The system shall be powered by its own dedicated power amplification module with DSP management, with the wiring connection via two 4-pin locking connector (one for input and one for link-out to another speaker), to allow for pre-wiring of the connector before installation.

The enclosure shall be of a moulded fibreglass composite with a smooth cellulose finish in any RAL colour and an aesthetic design. It shall contain an adjustable tilt mount for rigging and external dimensions of (H) 415 mm x (W) 719 mm x (D) 660 mm (16.3" x 28.3" x 26"). Weight shall be 23.5 kg (51.8 lbs).

The loudspeaker shall be the Void Acoustics Air Vantage.

7.2 Changelog

Document Version	Notes	Valid for S.N
UG10527-2.2	Updated specs to IEC 60268-5	A6VXXXX - Current

NORTH AMERICA

Void Acoustics North America

Call: +1 630 686 6616

Email: sales.usa@voidacoustics.com

HEAD OFFICE

Void Acoustics Research Ltd,
Unit L, The Fulcrum
Vantage Way
Poole
BH12 4NU
United Kingdom

Call: +44(0) 1202 666006

Email: hello@voidacoustics.com



Hear. Feel. Connect.

voidacoustics.com