

VOID

Hear. Feel. Connect.

voidacoustics.com



Xair

Ruthless, resilient bass

USER GUIDE V2.2

©2026 Void Acoustics Research Ltd.

This user guide is subject to change without notice.
For the latest online version, visit: www.voidacoustics.com

Void Acoustics and the Void logo are registered trademarks of Void Acoustics Research Ltd. in the United Kingdom, USA and other countries; all other Void trademarks are the property of Void Acoustics Research Ltd.

Contents

1	Safety and regulations	4
1.1	Important safety instructions	4
1.2	Limitations	4
1.3	EC declaration of conformity	4
1.4	UKCA Conformity	4
1.5	Warranty Statement	4
1.6	WEEE directive	4
1.7	Speaker Pole Mount Warning	4
2	Unpacking and Checking	5
3	About	6
3.1	Welcome	6
3.2	Xair overview	6
3.3	Key features	6
3.4	Specifications	7
3.5	Dimensions	7
4	Cable and wiring	8
4.1	Electrical Safety	8
4.2	Cable considerations for fixed installations	8
4.3	Impedance graph	8
4.4	Xair wiring diagram	9
4.5	Bias Q5 4-pin locking connector wiring	9
4.6	Amplifier loading guidelines	10
5	Operating Modes	11
5.1	Manual handling guidelines	11
5.2	Typical modes	11
6	Adjustments	12
6.1	Wheel removal	12
6.2	Grille removal	12
7	Service	14
7.1	Return authorisation	14
7.2	Shipping and packing considerations	14
8	Appendix	15
8.1	Architectural Specifications	15
8.2	Changelog	15

1 Safety and Regulations

1.1 Important safety instructions



The lightning flash with an arrowhead symbol within an equilateral triangle is intended to alert the user to the presence of uninsulated "dangerous voltage" within the product's enclosure that may be of sufficient magnitude to constitute a risk of electric shock to persons.



The exclamation point within an equilateral triangle is intended to alert the user of the presence of important operating and maintenance (servicing) instructions in the literature accompanying the appliance.

Safety instructions - read this first

1. Read these instructions.
2. Keep these instructions.
3. Heed all warnings.
4. Follow all instructions.
5. Do not use this apparatus near water.
6. Clean only with a dry cloth.
7. Do not block any ventilation openings. Install in accordance with the manufacturer's instructions.
8. Do not install near any heat source such as radiators, heat registers, stoves, or other such apparatus that produce heat.
9. Do not defeat the safety purpose of the grounding-type plug. A grounding type plug has two blades and a third grounding prong. The third prong is provided for your safety. If the provided plug does not fit into your outlet, consult an electrician for replacement of the obsolete outlet.
10. Protect power cords from being walked on or pinched particularly at plugs, convenience receptacles, and the point where they exit the apparatus.
11. Only use attachments and accessories specified by Void Acoustics.
12. Only use with the cart, stand, tripod, bracket, or table specified by the manufacturer, or sold with the apparatus. When a cart is used, use caution when moving the cart/apparatus combination to avoid injury from tip-over.
13. Unplug the apparatus during lightning storms or when unused for long periods of time.
14. Refer all servicing to qualified service personnel. Servicing is required when the apparatus has been damaged in any way, such as when the power-supply cord or plug is damaged, liquid has been spilled or objects have fallen into the apparatus, the apparatus has been exposed to rain or moisture, does not operate normally, or has been dropped.
15. Since the mains power supply cord attachment plug is used to disconnect the device, the plug should always be easily accessible.
16. Void loudspeakers can produce sound levels capable of causing permanent hearing damage from prolonged exposure. The higher the sound level, the less exposure needed to cause such damage. Avoid prolonged exposure to the high sound levels from the loudspeaker.

1.2 Limitations

This guide is provided to help familiarise the user with the loudspeaker system and its accessories. It is not intended to provide comprehensive electrical, fire, mechanical and noise training and is not a substitute for industry-approved training. Nor does this guide absolve the user of their obligation to comply with all relevant safety legislation and codes of practice. While every care has been taken in creating this guide, safety is user-dependent and Void Acoustics Research Ltd cannot guarantee complete safety whenever the system is rigged and operated.

1.3 EC declaration of conformity

For EC Declaration of Conformity please go to:

www.voidacoustics.com/eu-declaration-loudspeakers

1.4 UKCA marking

For details of the UKCA marking go to:

www.voidacoustics.com/uk-declaration-loudspeakers

1.5 Warranty statement

For warranty statement go to:

<https://voidacoustics.com/terms-conditions/>

1.6 WEEE directive

If the time arises to throw away your product, please recycle all the components possible.



This symbol indicates that when the end-user wishes to discard this product, it must be sent to separate collection facilities for recovery and recycling. By separating this product from other household-type waste, the volume of waste sent to incinerators or land-fills will be reduced and natural resources will thus be conserved.

The Waste Electrical and Electronic Equipment Directive (WEEE Directive) aims to minimise the impact of electrical and electronic goods on the environment. Void Acoustics Research Ltd complies with the Directive 2002/96/EC and 2003/108/EC of the European Parliament on waste electrical finance the cost of treatment and recovery of electronic equipment (WEEE) in order to reduce the amount of WEEE that is being disposed of in land-fill sites. All of our products are marked with the WEEE symbol; this indicates that this product must NOT be disposed of with other waste. Instead it is the user's responsibility to dispose of their waste electrical and electronic equipment by handing it over to an approved reprocessor, or by returning it to Void Acoustics Research Ltd for reprocessing. For more information about where you can send your waste equipment for recycling, please contact Void Acoustics Research Ltd or one of your local distributors.

1.7 Speaker Pole Mount Warning



M20 top hats are designed to support a maximum centric load of 35 kgs and not suitable for mounting heavier products such as the Air Motion or Tri Motion. Always place the base of the subwoofer on a flat and stable surface. The stability of the system depends on the height of the pole, and the size and weight of the speakers. It is the responsibility of the

user to ensure the assembled system is secure and stable. Misuse could lead to injury or equipment damage. Always make sure that the M20 pole is fully fastened into the threaded top hat, damaged is likely to occur if not secured tightly.



2 Unpacking and Checking

All Void Acoustics products are carefully manufactured and thoroughly tested before being despatched. Your dealer will ensure that your Void products are in pristine condition before being forwarded to you but mistakes and accidents can happen.

Before signing for your delivery:

- Inspect your shipment for any signs of contamination, abuse or transit damage as soon as you receive it
- Check your Void Acoustics delivery fully against your order
- If your shipment is incomplete or any of its contents are found to be damaged; inform the shipping company and inform your dealer.

When you are removing your Xair loudspeaker from its original packaging:

- Xair loudspeakers come packaged in a lid and base carton that has a protective sleeve around it; avoid using sharp implements to remove the cardboard to protect the finish
- If you need to place the loudspeaker on a flat surface make sure it is free from debris
- When you have removed the Xair loudspeaker from the packaging inspect it to ensure there is no damage and keep all original packaging in case it needs to be returned for any reason.

See section 1 for warranty conditions and see section 7 if your product needs servicing.

3 About

3.1 Welcome

Many thanks for purchasing this Void Acoustics Xair. We truly appreciate your support. At Void, we design, manufacture and distribute advanced professional audio systems for the installed and live sound market sectors. Like all Void products, our highly skilled and experienced engineers have successfully combined pioneering technologies with ground-breaking design aesthetics, to bring you superior sound quality and visual innovation. In buying this product, you are now part of the Void family and we hope using it brings you years of satisfaction. This guide will help you both use this product safely and ensure it performs to its full capability.

3.2 Xair overview

Air series edition of the Stasys XV2, the Xair is a reliable, versatile low frequency enclosure, specially designed with predictable behaviour you can trust. This cutting-edge design is available with the option for expressive colour customisation on the aluminium bracing. A tough 'TourCoat' polyurea finish and composition makes it well suited to events, tours or festivals; as well as a dance-floor favourite for nightclubs and live-music venues.

3.3 Key features:

- High output, double 18 inch, horn-loaded subwoofer
- Special 'Air' edition of Stasys XV2
- 3200 Watts AES power handling
- Negligible power compression
- Fast transient response and extremely low group delay
- Tough 'TourCoat' polyurea finish
- Truck pack friendly dimensions
- Universal location receptors
- Available as standard in black with red bracing. White finishes are available upon request, along with custom RAL and KROME options for the bracing

3 About

3.4 Specifications

Frequency Response ¹	33 Hz - Preset dependent
Maximum Output ²	139 dB cont, 145 dB peak
Nominal Dispersion	Array dependent
Sensitivity ³	104 dB 1W/1m
Driver Configuration	2 x 18" LF
Power Handling	3200 W AES
Nominal Impedance	4 Ω
Suggested Minimum Amplifier	Bias Q5
Weight	116 kg (255.7 lbs)
Connections	2 x 4-pin locking connector
Enclosure	18 mm birch plywood
Finish	Textured 'TourCoat' polyurea
Mounting	M20 top hat included
Height	562 mm (22.1")
Width	1226 mm (48.3")
Depth	903 mm (35.6")

1-10 dB IEC 60268-5 2 Calculated 3 Measured in half space

3.5 Dimensions

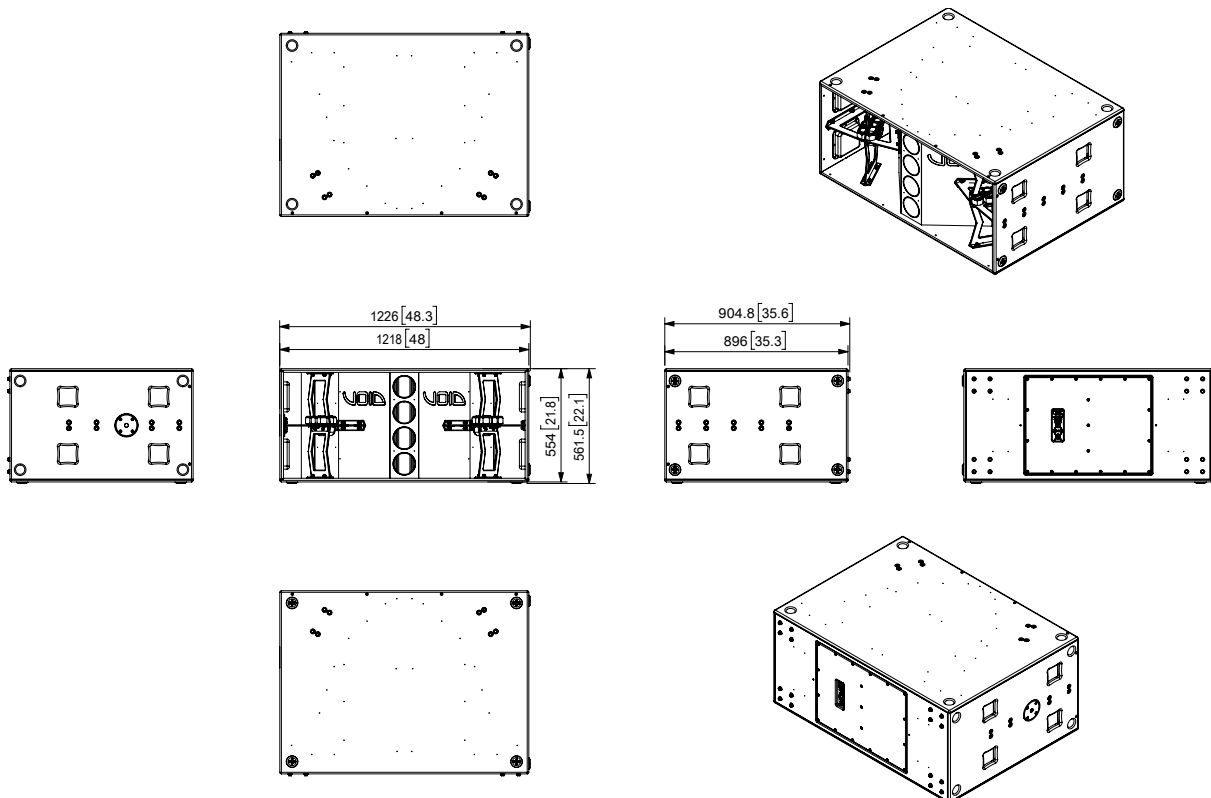

4 Cable and Wiring

4.1 Electrical safety



To avoid electrical hazards please note the following:

- Do not access the inside of any electrical equipment. Refer servicing to Void-approved service agents.

4.2 Cable considerations for fixed installations

We recommend specifying installation-grade Low Smoke Zero Halogen (LSZH) cables for permanent installations. The cables should use Oxygen Free Copper (OFC) of grade C11000 or above. Cables for permanent installations should be compliant with the following standards:

- IEC 60332.1 Fire retardancy of a single cable
- IEC 60332.3C Fire retardancy of bunched cables
- IEC 60754.1 Amount of Halogen Gas Emissions
- IEC 60754.2 Degree of acidity of released gases
- IEC 61034.2 Measurement of smoke density.

We suggest using the following maximum copper cable lengths to keep level losses below 0.6 dB.

Metric mm ²	Imperial AWG	4 Ω load	2 Ω load
2.50 mm ²	13 AWG	18 m	9 m
4.00 mm ²	11 AWG	30 m	15 m

4.3 Impedance graph

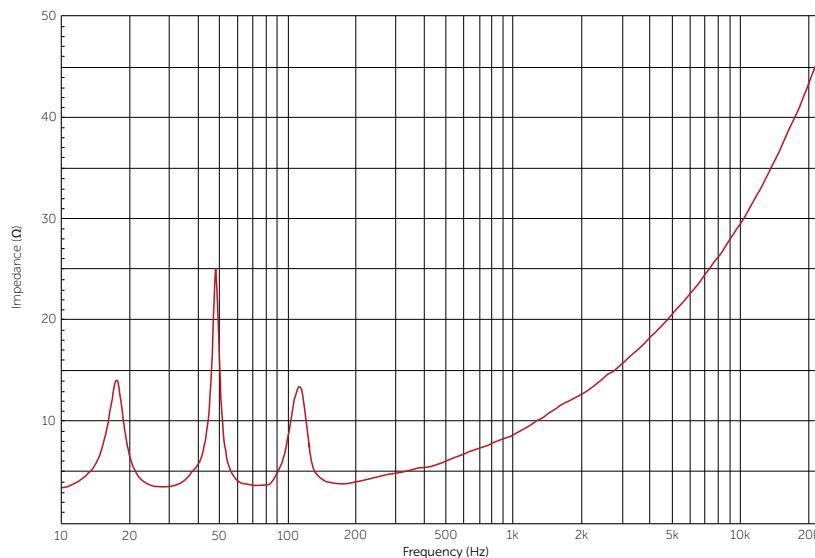

Figure 4.1: Impedance graph

4 Cable and Wiring

4.4 Xair wiring diagram

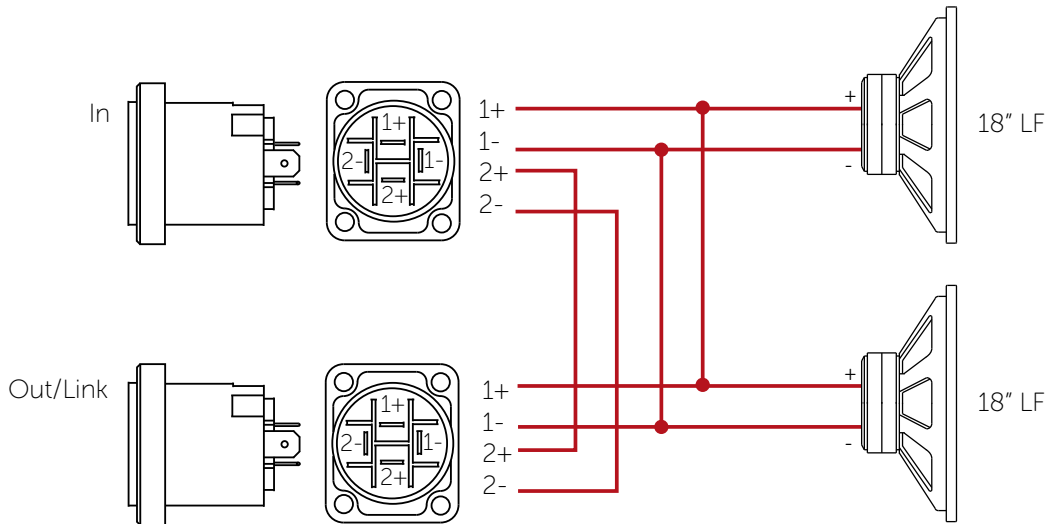

Figure 4.2: Xair wiring diagram

	4-pin locking connector pins 1+/1-	4-pin locking connector pins 2+/2-
In	LF (2 x 18")	n/c
Out	Link/out	n/c

4.5 Bias Q5 4-pin locking connector wiring

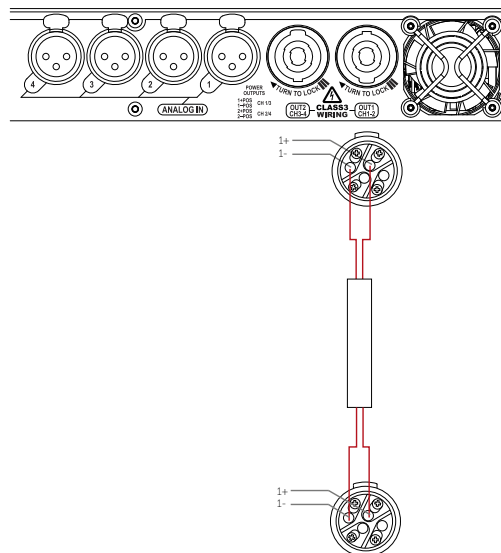

Figure 4.3: Bias Q5

Bias Q5	Output 1 or 2
Output	LF (2 x 18")
Max parallel units	2 (2 Ω load to amplifier)

4 Cable and Wiring

4.6 Amplifier loading guidelines

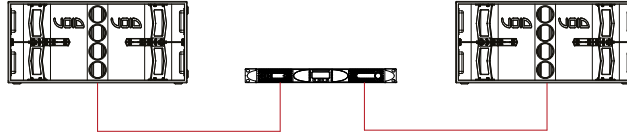

Figure 4.5: 2 x Xair: 4 Ω per channel/1 amplifier

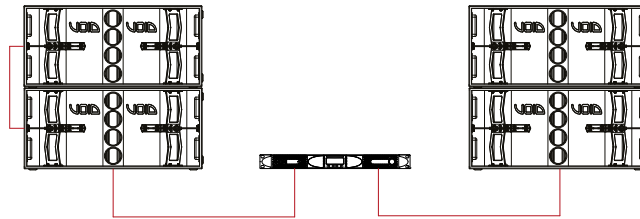

Figure 4.5: 4 x Xair: 2 Ω per channel/1 amplifier

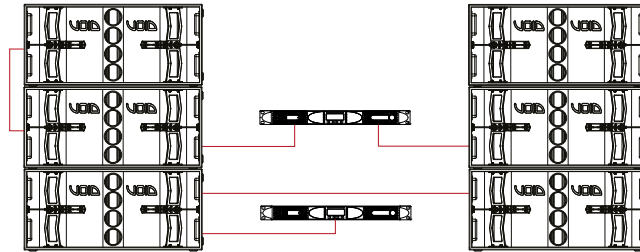

Figure 4.6: 6 x Xair: 2 Ω per channel/2 amplifier

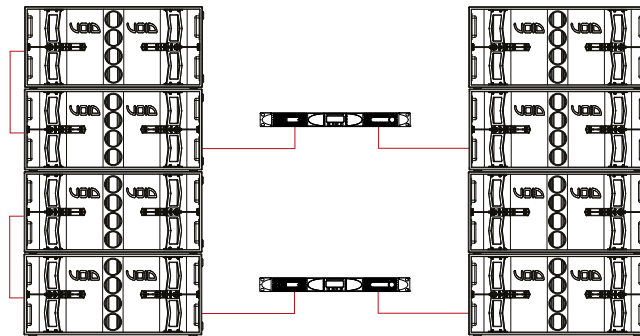

Figure 4.7: 8 x Xair: 2 Ω per channel/2 amplifier

Ensure all amplifier channels are loaded equally. Limiters engage correctly. Cabinets acoustic principles are the same.

5 Operating Modes

5.1 Manual handling guidelines



To avoid manual handling hazards please note the following:

- Be sure to secure any loudspeaker systems following correct local procedures/guideline
- Low frequency enclosures are heavy and require a minimum of two people to move; for more information on safe handling consult INDG143.

5.2 Typical modes

Although the modes of arrangement shown here are typical operating modes for low frequency enclosures, the Xair system's symmetrical design lends itself to wide range of configurations. Simple planer arrays and stacks to directional and steerable arrays are possible given suitable electronics and presets. Contact your local Void distributor/dealer for more information.

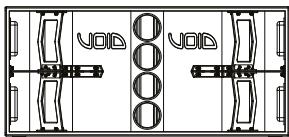

Single



Horizontal

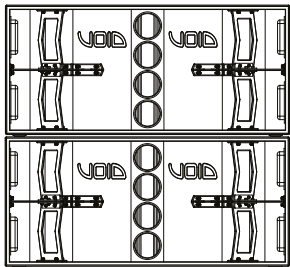

Vertical

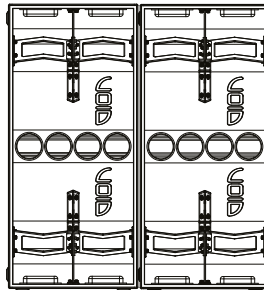

On-end

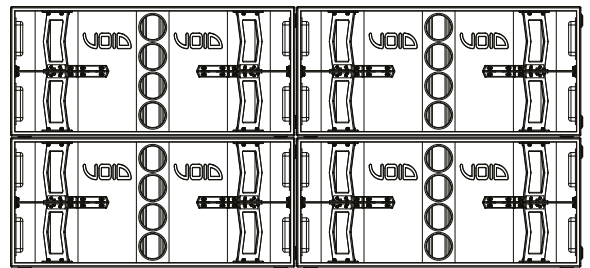

Block

Figure 5.1: Typical mode layouts

6 Adjustments

To avoid damage when making adjustments please note the following:



- Removing the grille can cause debris to collect within the enclosure, take care to remove anything that may have collected internally
- Do not use impact tools.

6.1 Wheel removal

Step 1:
Remove all four M8 bolts with a 13 mm spanner/wrench.

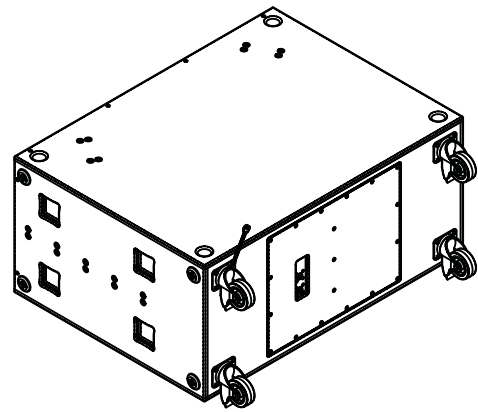

Figure 6.1: Bolt removal

Step 2:
Remove/add the wheels and keep in a safe place. Repeat the process for the other three wheels.

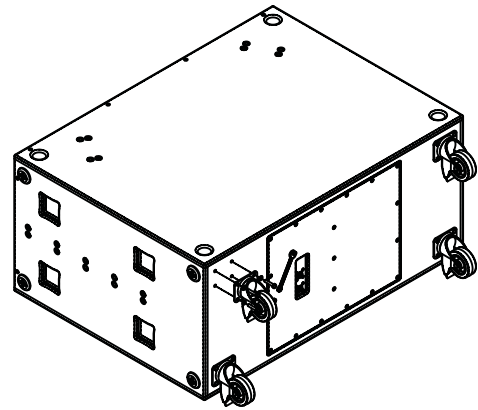

Figure 6.2: Wheel removal

Step 3:
Replace the M8 bolts by hand until finger tight before using hand tools.



Note: Replacing bolts is of particular importance as without them there can be air leakage and detuning.

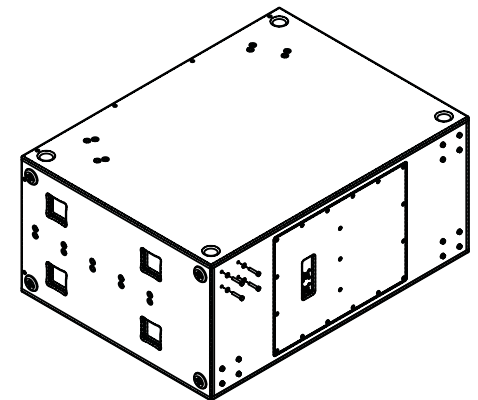

Figure 6.3: Bolt tightening

6 Adjustments

6.2 Grille removal

Step 1:

Undo all twelve M6 tab bolts using a 4 mm Allen key, take care NOT to remove the tab bolts as they may become lost within the enclosure.

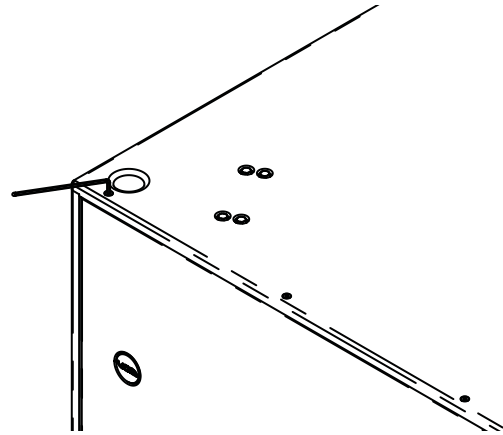

Figure 6.4: Bolt removal

Step 2:

Remove grille.

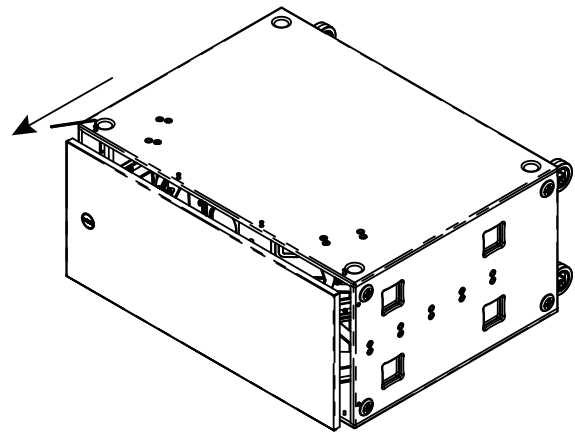

Figure 6.5: Grille removal

Step 3:

Replace the M6 bolts by hand until finger tight before using hand tools.

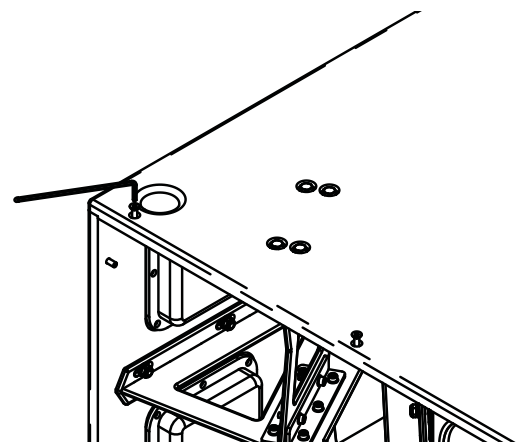

Figure 6.6: Bolt replacement

7 Service

Void Xair loudspeakers should only be serviced by a fully-trained technician.



No user serviceable parts inside. Refer servicing to your dealer.

7.1 Return authorisation

Before returning your faulty product for repair, please remember to get an R.A.N. (Return Authorisation Number) from the Void dealer who supplied the system to you. Your dealer will handle the necessary paperwork and repair. Failure to go through this return authorisation procedure could delay the repair of your product.

Note that your dealer will need to see a copy of your sales receipt as proof of purchase so please have this to hand when applying for return authorisation.

7.2 Shipping and packing considerations

- When sending a Void Xair loudspeaker to an authorised service centre, please write a detailed description of the fault and list any other equipment used in conjunction with the faulty product.
- Accessories will not be required. Do not send the instruction manual, cables or any other hardware unless your dealer asks you to.
- Pack your unit in the original factory packaging if possible. Include a note of the fault description with the product. Do not send it separately.
- Ensure safe transportation of your unit to the authorised service centre.

8 Appendix

8.1 Architectural specifications

The loudspeaker shall be an active bandpass sub bass system consisting of two high power 18" (455 mm), long excursion, low frequency (LF) transducers mounted in a rectangular enclosure.

The low frequency transducers shall be constructed on a cast aluminium frame, with a treated paper cone, dual 101.6 mm (4") voice coil, wound with copper wires on a high quality voice coil former and a neodymium magnet for high power handling and long-term reliability.

Performance specifications for a typical production unit shall be as follows: the usable bandwidth of 33 Hz to preset dependent (-10 dB IEC 60268-5), with a maximum SPL of 145 dB peak (139 dB continuous) measured at 1 m using IEC268-5 pink noise. Power handling shall be at 3200 W AES at a rated impedance of 4 Ω . Pressure sensitivity shall be 104 dB measured at 1W/1m. The system shall be powered by its own dedicated power amplification module with DSP management, with the wiring connection via two 4-pin locking connector (one for input and one for loop-out to another speaker), to allow for pre-wiring of the connector before installation.

The enclosure shall be constructed from an 18 mm multi-laminate birch plywood finished in a textured polyurea and contain fixture points for a pressed steel, powder coated grille to protect the horn path from object ingress. The cabinet shall have eight handles (four per side) for efficient manual handling. External dimensions of (H) 562 mm x (W) 1226 mm x (D) 903 mm (22.1" x 48.3" x 35.6"). Weight shall be 116 kg (255.7 lbs).

The loudspeaker shall be the Void Acoustics Xair.

8.2 Changelog

Document Version	Notes	Valid for S.N
UG10526-2.2	Updated specs to IEC 60268-5	SXV2AXX - Current

NORTH AMERICA

Void Acoustics North America

Call: +1 (630) 686 6616

Email: sales.usa@voidacoustics.com

HEAD OFFICE

Void Acoustics Research Ltd

Unit L, The Fulcrum

Vantage Way

Poole

BH12 4NU

United Kingdom

Call: +44(0) 1202 666006

Email: hello@voidacoustics.com



Hear. Feel. Connect.

voidacoustics.com