

VOID

Hear. Feel. Connect.



Air Motion

Iconic Styling, Incredible Performance

USER GUIDE V2.2

©2026 Void Acoustics Research Ltd.

This user guide is subject to change without notice.
For the latest online version, visit: www.voidacoustics.com

Void Acoustics and the Void logo are registered trademarks of Void Acoustics Research Ltd. in the United Kingdom, USA and other countries; all other Void trademarks are the property of Void Acoustics Research Ltd.

Contents

1	Safety and regulations	4
1.1	Important safety instructions	4
1.2	Limitations	4
1.3	EC declaration of conformity	4
1.4	UKCA Conformity	4
1.5	Warranty Statement	4
1.6	WEEE directive	4
2	Unpacking and Checking	5
3	About	6
3.1	Welcome	6
3.2	Air Motion overview	6
3.3	Key features	6
3.4	Air Motion specifications	7
3.5	Air Motion dimensions	8
4	Cable and wiring	9
4.1	Electrical safety	9
4.2	Cable considerations for fixed installations	9
4.3	Air Motion wiring diagram	10
4.4	Bias D1+/Q1+/Q1.5+/Q2+ phoenix wiring	11
4.5	Bias Q3/Q5 4-pin locking connector wiring	11
5	Mounting	12
5.1	Installation safety	12
5.2	Mounting the U bracket	13
5.3	Air Motion ground stacking	15
5.4	Wall mounting	17
5.5	Ceiling mounting	19
5.6	Truss mounting	21
5.7	Ceiling pole mounting	23
5.8	Pole mounting	25
6	Service	27
6.1	Return authorisation	27
6.2	Shipping and packing considerations	27
7	Appendix	28
7.1	Architectural Specifications	28
7.2	Changelog	29

1 Safety and Regulations

1.1 Important safety instructions



The lightning flash with an arrowhead symbol within an equilateral triangle is intended to alert the user to the presence of uninsulated "dangerous voltage" within the product's enclosure that may be of sufficient magnitude to constitute a risk of electric shock to persons.



The exclamation point within an equilateral triangle is intended to alert the user of the presence of important operating and maintenance (servicing) instructions in the literature accompanying the appliance.

Safety instructions - read this first

1. Read these instructions.
2. Keep these instructions.
3. Heed all warnings.
4. Follow all instructions.
5. Do not use this apparatus near water.
6. Clean only with a dry cloth.
7. Do not block any ventilation openings. Install in accordance with the manufacturer's instructions.
8. Do not install near any heat source such as radiators, heat registers, stoves, or other such apparatus that produce heat.
9. Do not defeat the safety purpose of the grounding-type plug. A grounding type plug has two blades and a third grounding prong. The third prong is provided for your safety. If the provided plug does not fit into your outlet, consult an electrician for replacement of the obsolete outlet.
10. Protect power cords from being walked on or pinched particularly at plugs, convenience receptacles, and the point where they exit the apparatus.
11. Only use attachments and accessories specified by Void Acoustics.
12. Only use with the cart, stand, tripod, bracket, or table specified by the manufacturer, or sold with the apparatus. When a cart is used, use caution when moving the cart/apparatus combination to avoid injury from tip-over.
13. Unplug the apparatus during lightning storms or when unused for long periods of time.
14. Refer all servicing to qualified service personnel. Servicing is required when the apparatus has been damaged in any way, such as when the power-supply cord or plug is damaged, liquid has been spilled or objects have fallen into the apparatus, the apparatus has been exposed to rain or moisture, does not operate normally, or has been dropped.
15. Since the mains power supply cord attachment plug is used to disconnect the device, the plug should always be easily accessible.
16. Void loudspeakers can produce sound levels capable of causing permanent hearing damage from prolonged exposure. The higher the sound level, the less exposure needed to cause such damage. Avoid prolonged exposure to the high sound levels from the loudspeaker.

1.2 Limitations

This guide is provided to help familiarise the user with the loudspeaker system and its accessories. It is not intended to provide comprehensive electrical, fire, mechanical and noise training and is not a substitute for industry-approved training. Nor does this guide absolve the user of their obligation to comply with all relevant safety legislation and codes of practice. While every care has been taken in creating this guide, safety is user-dependent and Void Acoustics Research Ltd cannot guarantee complete safety whenever the system is rigged and operated.

1.3 EC declaration of conformity

For EC Declaration of Conformity please go to:

www.voidacoustics.com/eu-declaration-loudspeakers

1.4 UKCA marking

For details of the UKCA marking go to:

www.voidacoustics.com/uk-declaration-loudspeakers

1.5 Warranty statement

For warranty statement go to:

<https://voidacoustics.com/terms-conditions/>

1.6 WEEE directive

If the time arises to throw away your product, please recycle all the components possible.



This symbol indicates that when the end-user wishes to discard this product, it must be sent to separate collection facilities for recovery and recycling. By separating this product from other household-type waste, the volume of waste sent to incinerators or land-fills will be reduced and natural resources will thus be conserved.

The Waste Electrical and Electronic Equipment Directive (WEEE Directive) aims to minimise the impact of electrical and electronic goods on the environment. Void Acoustics Research Ltd complies with the Directive 2002/96/EC and 2003/108/EC of the European Parliament on waste electrical and electronic equipment (WEEE) in order to reduce the amount of WEEE that is being disposed of in land-fill sites. All of our products are marked with the WEEE symbol; this indicates that this product must NOT be disposed of with other waste. Instead it is the user's responsibility to dispose of their waste electrical and electronic equipment by handing it over to an approved reprocessor, or by returning it to Void Acoustics Research Ltd for reprocessing. For more information about where you can send your waste equipment for recycling, please contact Void Acoustics Research Ltd or one of your local distributors.



2 Unpacking and Checking

All Void Acoustics products are carefully manufactured and thoroughly tested before being despatched. Your dealer will ensure that your Void products are in pristine condition before being forwarded to you but mistakes and accidents can happen.

Before signing for your delivery:

- Inspect your shipment for any signs of contamination, abuse or transit damage as soon as you receive it
- Check your Void Acoustics delivery fully against your order
- If your shipment is incomplete or any of its contents are found to be damaged; inform the shipping company and inform your dealer.

Air Motion loudspeakers are heavy (35.4 kg/78 lbs) and require a minimum two people to lift.

- Undo the four butterfly catches on the transport case then remove the lid making sure the lid is clear before moving sideways
- If you need to place the Air Motion on a flat surface ensure you use a lint free product to protect the finish
- To remove from the transport case, each person should hold the Air Motion on each side, with one hand on the edge of the horn flare, and the other supporting the weight of the drivers to the rear, as shown in figure 2.1
- When removing the Air Motion take care not to damage the lower tray of the transport case.

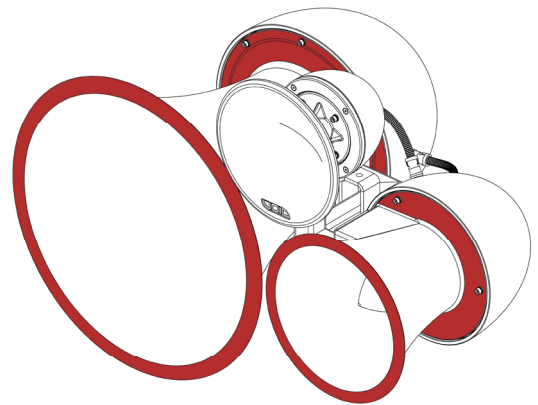

Figure 2.1: Safe handling positions diagram
(Indicated in red)

Keep the original packaging in case you need to return a product for service later.

See section 1.5 for warranty conditions and see section 6 if your product needs servicing.

3 About

3.1 Welcome

Many thanks for purchasing this Void Acoustics Air Motion. We truly appreciate your support. At Void, we design, manufacture and distribute advanced professional audio systems for the installed and live sound market sectors. Like all Void products, our highly skilled and experienced engineers have successfully combined pioneering technologies with ground-breaking design aesthetics, to bring you superior sound quality and visual innovation. In buying this product, you are now part of the Void family and we hope using it brings you years of satisfaction. This guide will help you both use this product safely and ensure it performs to its full capability.

3.2 Air Motion overview

The Air Motion is a timeless work of art, instantly recognisable as a Void-signature product, known for both its iconic appearance and exceptionally balanced sound.

3.3 Key features

- Three-way, bi-amped sculpted loudspeaker array
- Wide 60°H x 50°V dispersion for controlled coverage
- FIR optimised preset with Void amplifiers
- Low-resonance fibreglass composite construction
- Integrated flying and mounting system
- Visually striking appearance for style led environments
- Available in left and right configurations
- Available as standard in red, black, and white
- Custom RAL and KROME finishes are available upon request

3 About

3.4 Air Motion specifications

Frequency Response ¹	135 Hz - 20 kHz
Maximum Output ²	132 dB cont, 138 dB peak
Nominal Dispersion	60°H x 50°V
Sensitivity ³	LF: 106 dB 1W/1m, MHF: 108 dB 1W/1m
Driver Configuration	1 x 12" LF, 1 x 8" MF, 1 x 1.5" HF compression driver
Power Handling	LF: 500 W AES, MHF: 250 W AES
Nominal Impedance	LF: 8 Ω , MHF: 8 Ω
Suggested Minimum Amplifier	Bias Q1.5+
Weight	35.4 kg (78 lbs)
Connections	2 x 4-pin locking connector
Enclosure	Fibreglass composite
Finish	Smooth cellulose
Mounting	Integral mounting system
Height	672 mm (26.5")
Width	854 mm (33.6")
Depth	658 mm (25.9")
Colour	Custom colours available upon request

1-10 dB IEC 60268-5 2 Calculated 3 Measured in half space

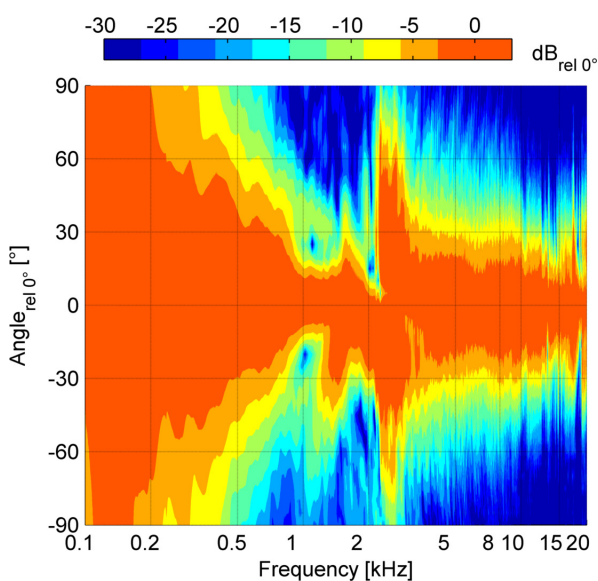

Figure 3.1: Horizontal directivity isobars

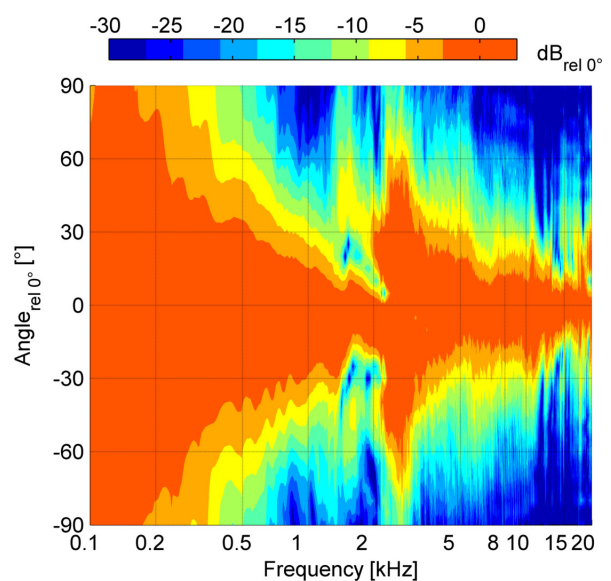

Figure 3.2: Vertical directivity isobars

3 About

3.5 Air Motion dimensions

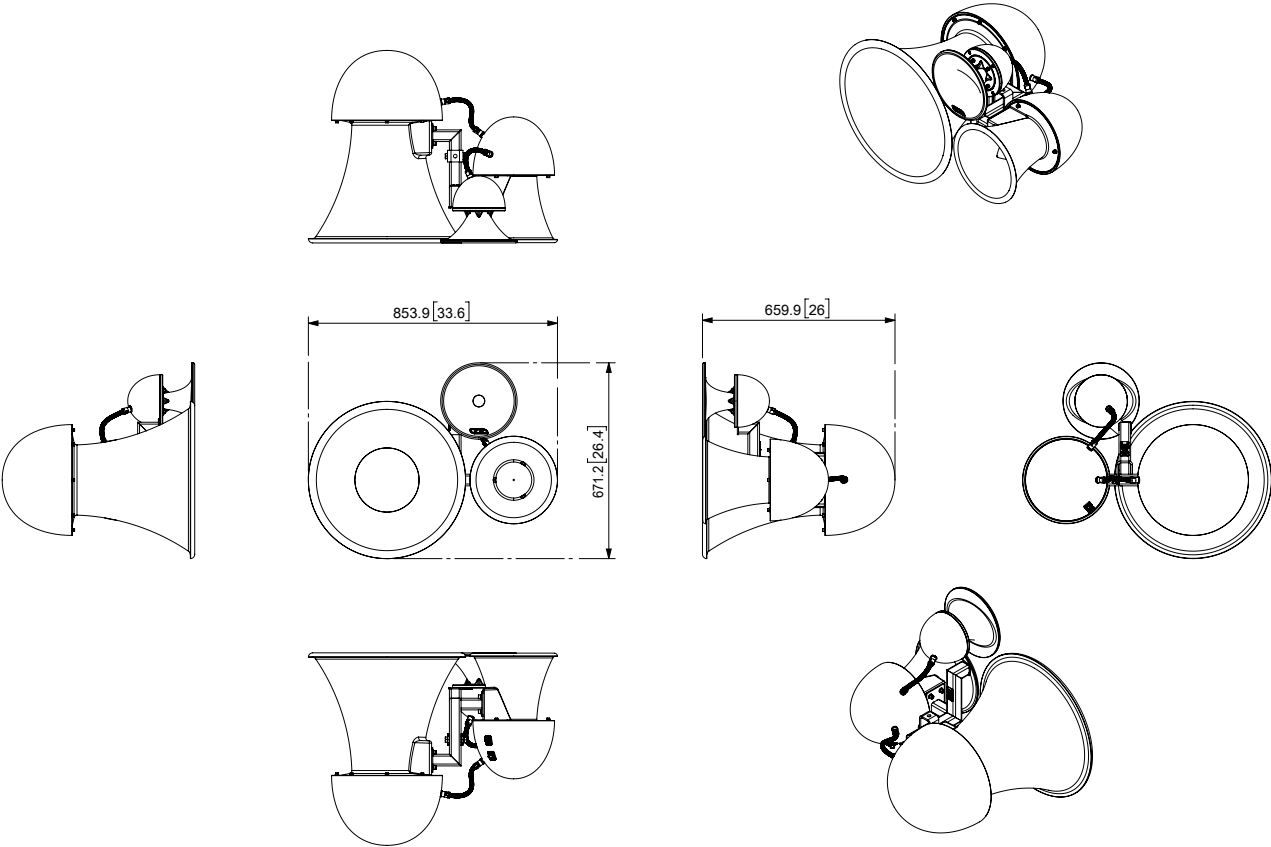

Figure 3.3: Dimensions (right-handed)

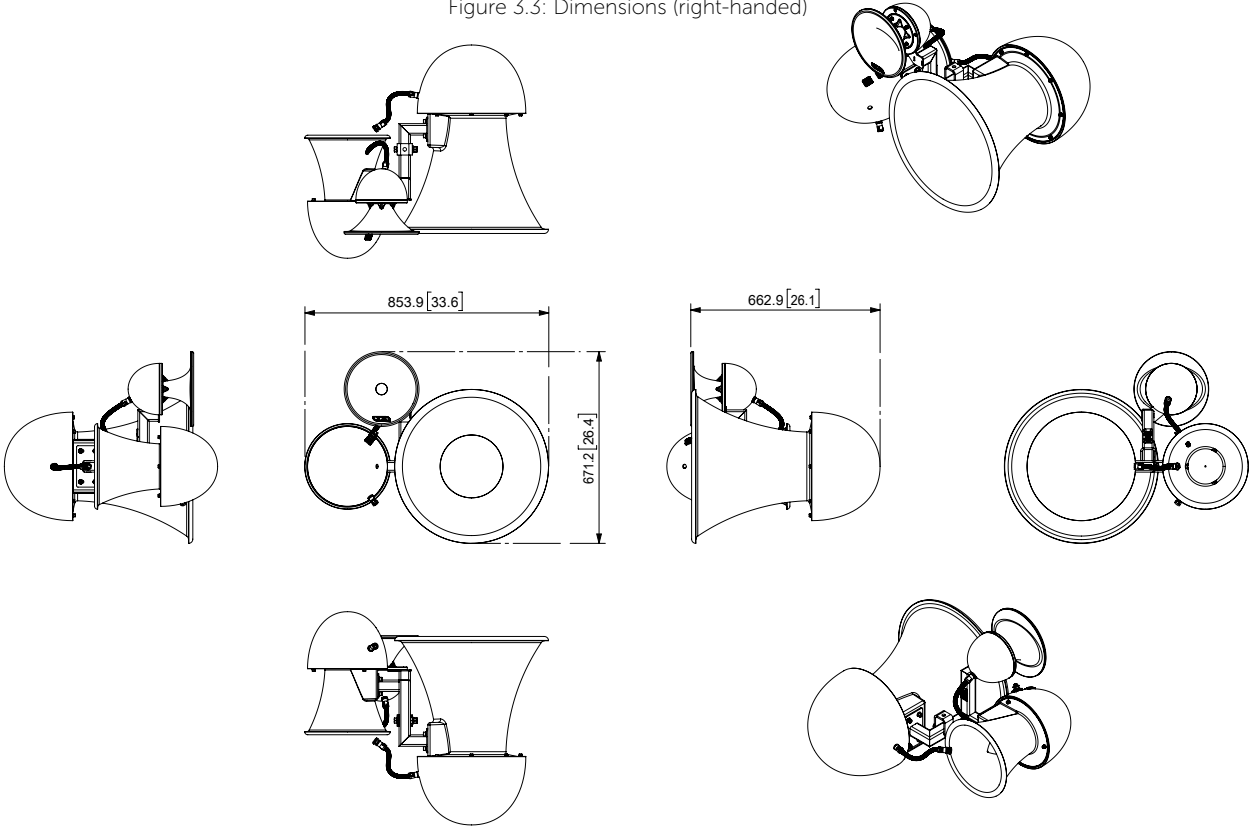

Figure 3.4: Dimensions (left-handed)

4 Cable and Wiring

4.1 Electrical safety



To avoid electrical hazards please note the following:

- Do not access the inside of any electrical equipment. Refer servicing to Void-approved service agents.

4.2 Cable considerations for fixed installations

We recommend specifying installation-grade Low Smoke Zero Halogen (LSZH) cables for permanent installations. The cables should use Oxygen Free Copper (OFC) of grade C11000 or above. Cables for permanent installations should be compliant with the following standards:

- IEC 60332.1 Fire retardancy of a single cable
- IEC 60332.3C Fire retardancy of bunched cables
- IEC 60754.1 Amount of Halogen Gas Emissions
- IEC 60754.2 Degree of acidity of released gases
- IEC 61034.2 Measurement of smoke density.

Air Motion loudspeakers are 3-way, bi-amplified. They require two amplifier channels to drive them via 4-pin locking connector cables. We suggest using the following maximum copper cable lengths to keep level losses below 0.6 dB.

Metric mm ²	Imperial AWG	8 Ω load	4 Ω load	2 Ω load
2.50 mm ²	13 AWG	36 m	18 m	9 m
4.00 mm ²	11 AWG	60 m	30 m	15 m

4 Cable and Wiring

4.3 Air Motion wiring diagram

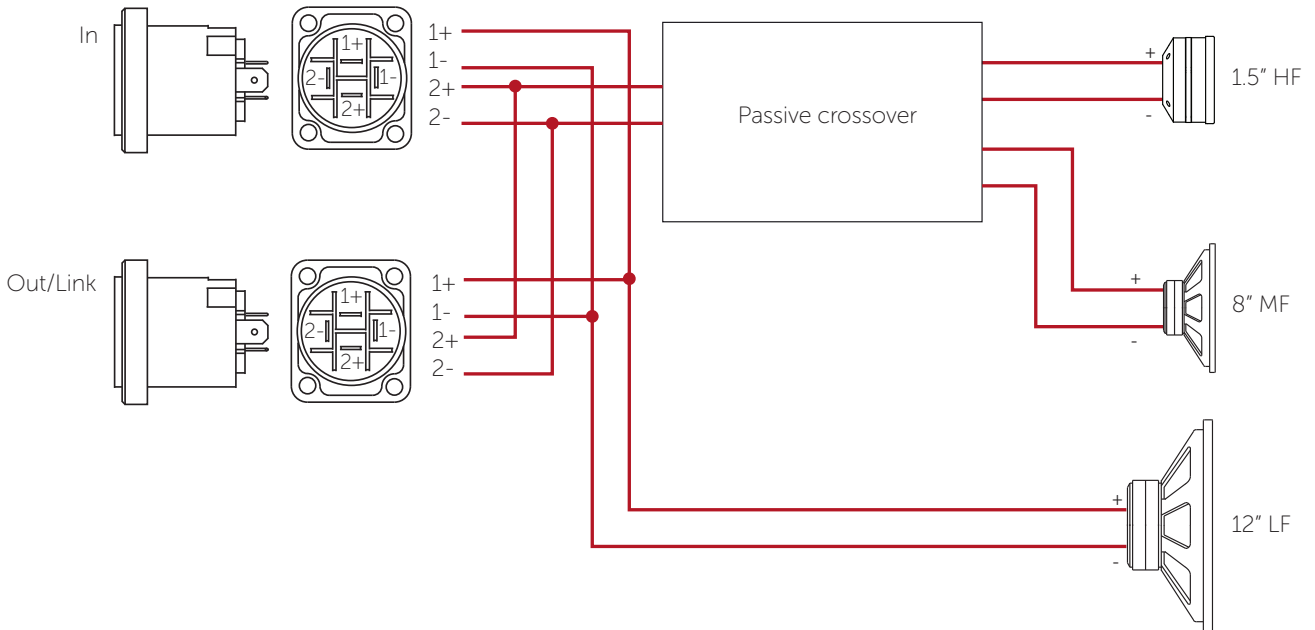

Figure 4.1: Wiring diagram

	4-pin locking connector pins 1+/1-	4-pin locking connector pins 2+/2-
In	LF (12")	MHF (8" + 1.5")
Out	LF link	MHF link

4 Cable and Wiring

4.4 Bias D1+/Q1+/Q1.5+/Q2+ phoenix wiring

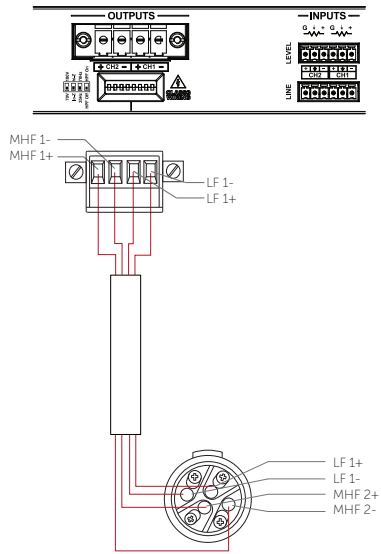

Figure 4.2: Bias D1

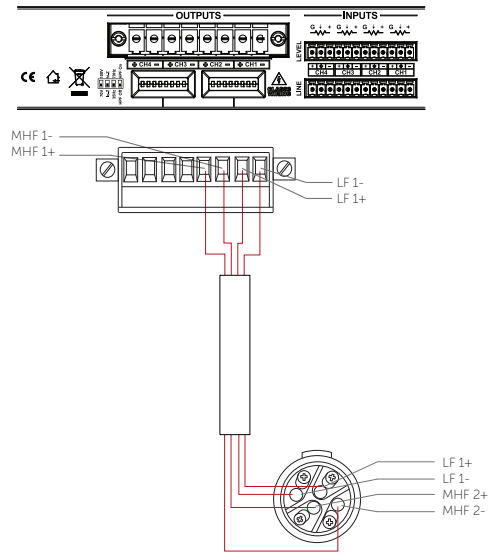

Figure 4.3: Bias Q1/Q2

Bias D1+/Q1+/Q1.5+/Q2+	Output 1	Output 2
Output	LF (12")	MHF (8"+1.5")
Max parallel units	4 (2 Ω load to amplifier)*	4 (2 Ω load to amplifier)*

*Recommended max parallel units 2 (4 Ω load to amplifier) due to the power rating of the amplifier.

4.5 Bias Q3/Q5 4-pin locking connector wiring

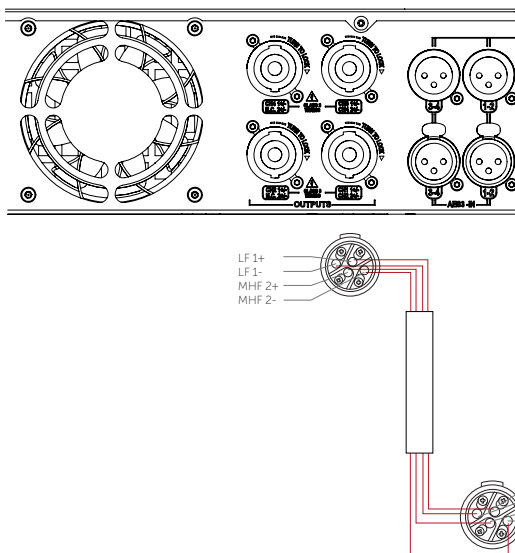

Figure 4.4: Bias Q3

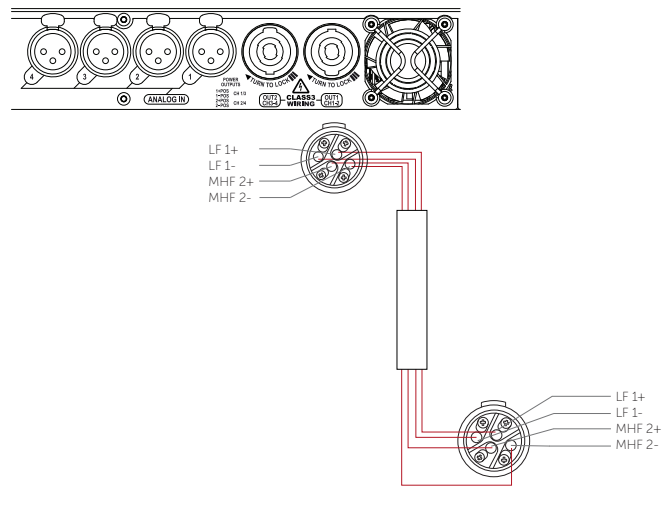

Figure 4.5: Bias Q5

Bias Q3/Q5	Output 1	Output 2
Output	LF (12")	MHF (8"+1.5")
Max quantity per channel	2 (4 Ω load to amplifier)	2 (4 Ω load to amplifier)

5 Mounting

Tools required

- 19 mm ratchet spanner/wrench
- 6 mm Allen key

5.1 Installation safety



To avoid mechanical hazards, please note the following:

- Safety regulations vary in different regions. Full compliance with those regulations must be your priority
- Installations must only be undertaken by fully qualified and experienced engineers/technicians who understand local regulations
- This may include consulting a structural engineer before installation of wall brackets
- Remember that all personnel have a duty of care to themselves, to their assistants, to the venue staff and to the public
- Before lifting any part of the system above head height, check the whole rig for loose tools or other items that may fall and cause injury
- Do not use a telephone (even if hands-free) whilst installing. Always concentrate fully on the installation operation
- Do not install equipment that is worn, damaged, corroded, mishandled or overstressed in any way
- Use only Void-approved mounting equipment and accessories
- Secondary safeties should be provided in all instances where cabinets are flying or fixing overhead and should conform to local regulations

5.2 Mounting the U Bracket

Parts required:

TU - Stud Bracket	White - IT1085
	Black - IT1083

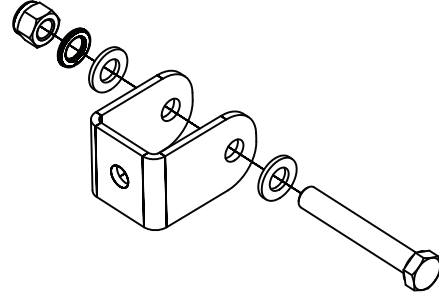

Figure 5.1: TU Stud Bracket

Step 1:

Lay a soft lint-free rug clear of debris on a work surface to avoid damage to the loudspeaker. Place the Air Motion with the horns face down and remove all four M8 socket cap Allen bolts from the 12" LF driver.

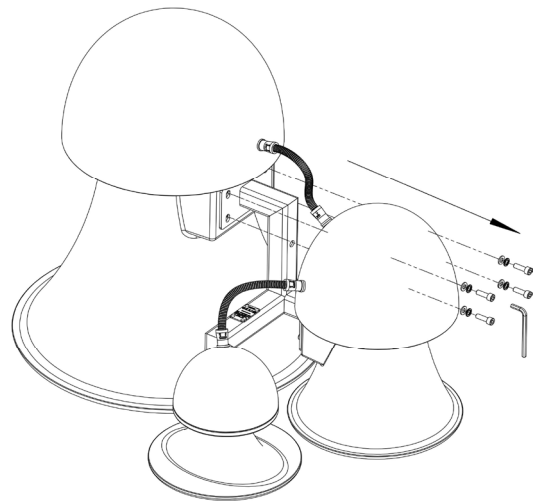

Figure 5.2: M8 socket cap removal

Step 2:

Remove the 12" LF driver from the main bracket taking care not to place any strain on the cable connecting to the 8" mid driver.

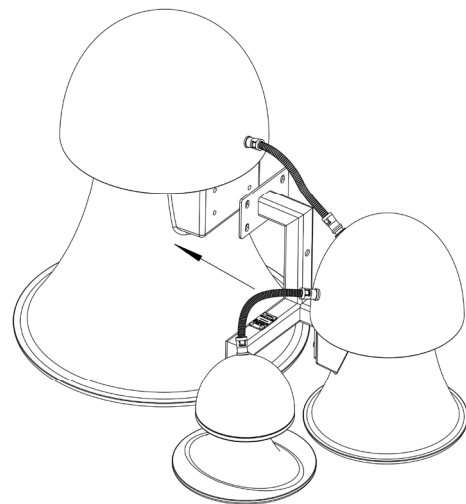

Figure 5.3: M8 LF driver removal

5.2 Mounting the U Bracket

Step 3:

Insert the U bracket for the desired orientation. Then insert the M12 x 70 mm bolt through the non-threaded side of the U bracket, 12" LF driver side, and tighten the bolt. Then tighten the M12 Aerotight nut to the 8" mid driver side.

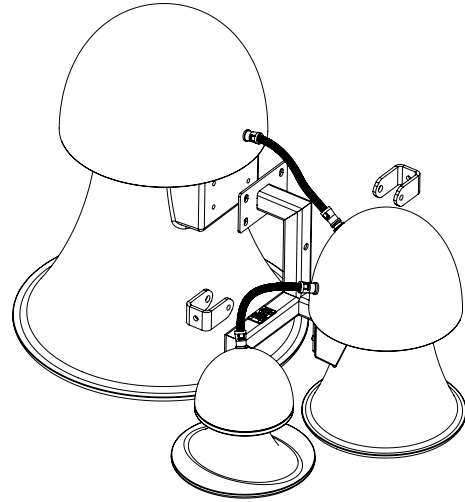

Figure 5.4: U bracket positioning



Note:

The U bracket is threaded for the bolt on one side only. Ensure that the threaded side faces the 8" MHF driver and the non-threaded side faces the 12" LF driver.

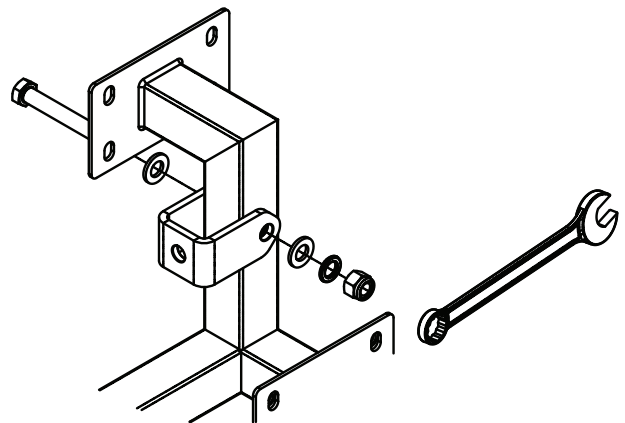

Figure 5.5: M12 x 70 mm bolt insertion

Step 4:

Finally reattach the 12" LF driver with the four M8 socket cap Allen bolts, taking care not to over tighten.

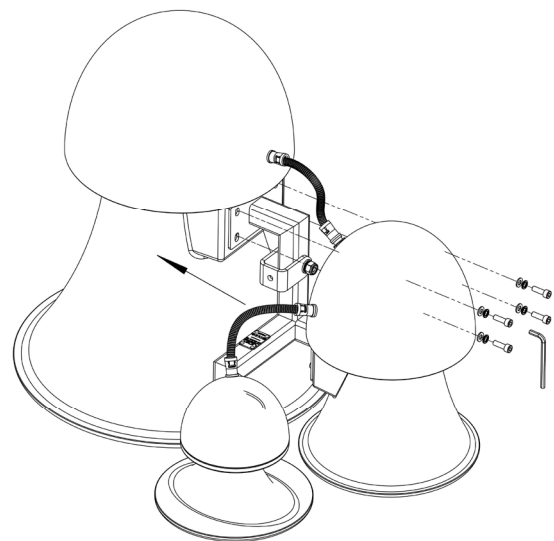

Figure 5.6: M8 socket cap reattaching

5.3 Air Motion Ground Stacking

Parts required:

Stasys X V2/Xair Mounting Board	White - IT1592
	Black - IT1591
TU - Multi Bracket (600mm)	White - IT1089
	Black - IT1088

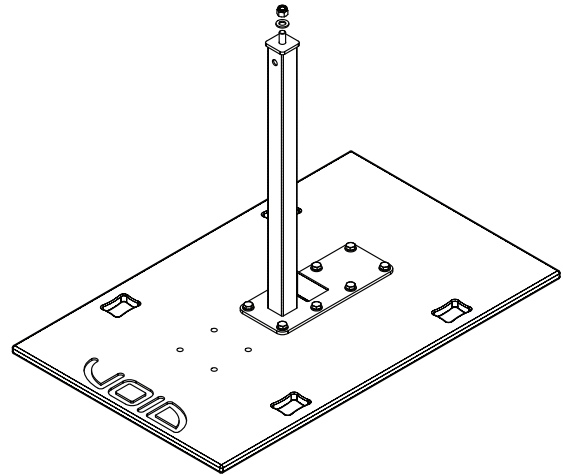

Figure 5.7: Stasys Xair/X V2 mounting board with bracket

Step 1:
Remove M12 nut from the stand using a 19 mm ratchet spanner.

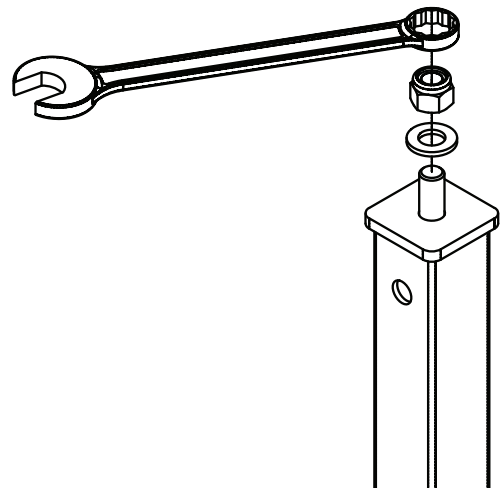

Figure 5.8: M12 Aerotight nut removal



Step 2:

Lift the Air Motion with two people (with one hand on the edge of the horn flare and the other supporting the weight of the drivers at the rear) and position the mounting hole over the stand bolt. For safe handling locations see section 2.

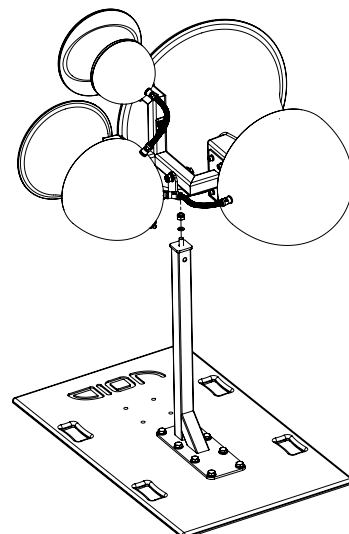

Figure 5.9: Air Motion mounting

5.3 Air Motion Ground Stacking

Step 3:

Tighten the M12 Aerotight nut using a 19 mm ratchet spanner while another person supports the Air Motion.

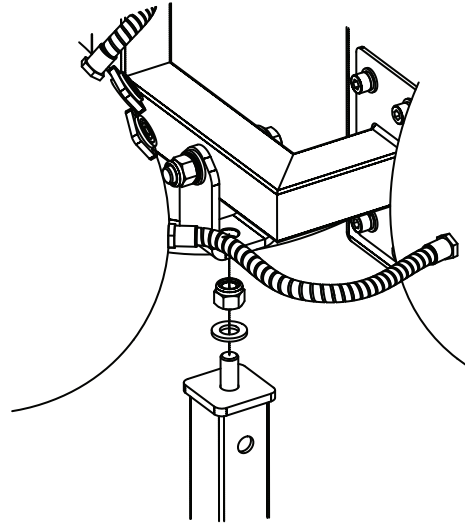

Figure 5.10: M12 Aerotight nut tightening

Step 4:

Confirm the Air Motion is securely fastened to the stand, and lift the assembly onto the bass-cabinet with suitable equipment.



The assembly is heavy; be aware of the high centre of gravity! You will need to tilt the mounting board forward to place one hand under the board and get a secure grip on the hand hold. Then place your other hand on the horn-flare. Raise the assembly to the bass cabinet and slide until the feet drop into the feet pockets. If the bass cabinet is on an uneven surface, ensure that it is stabilised with wedges before mounting the Air Motion.

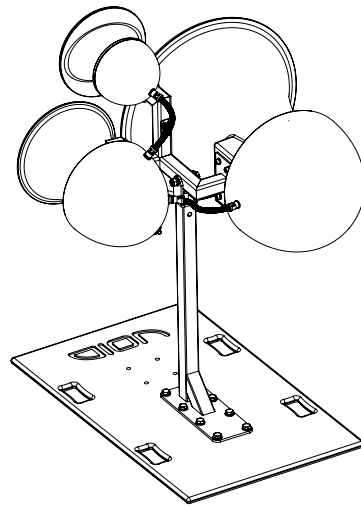

Figure 5.11: Air Motion on mounting board and bracket

Step 5:

Secure with a minimum of one 1 tonne SWL ratchet straps. Ensure the stand is secured from sliding or rotating and on a level surface.

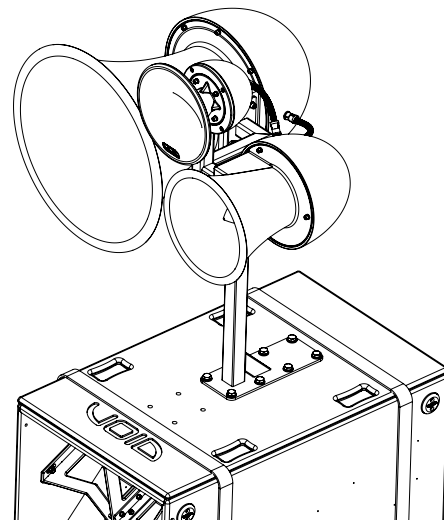

Figure 5.12: Air Motion mounted on bass-cabinet

5.4 Wall Mounting

Parts required:

Multi Bracket Extension	White - IT2088
	Black - IT2089
TU - Multi Bracket (600mm)	White - IT1089
	Black - IT1088

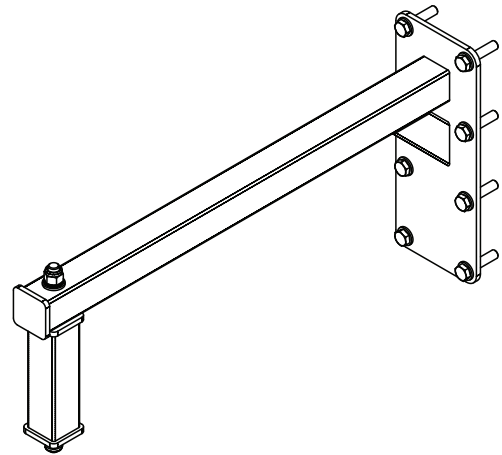

Figure 5.13: TU - Multi Bracket (600mm) with extension piece

Step 1:

Begin by fixing the bracket to the wall and then fix the extension piece to the bracket with the M12 nut using a 19 mm ratchet spanner.



All eight bolts must be fitted when securing the bracket to the wall. Take care when mounting the bracket to the wall, making sure to use the correct fixing and that the wall can take the load.

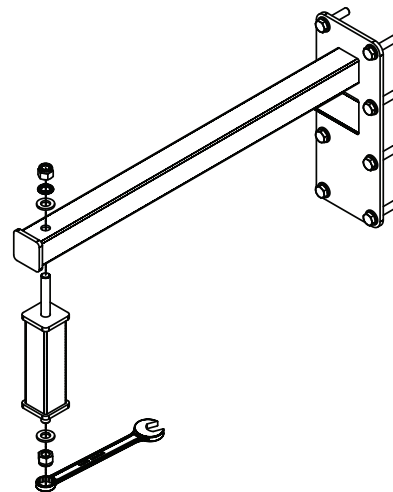

Figure 5.14: Extension piece assembly

Step 2:

Lift the Air Motion into position making sure to hold by the safe lifting positions detailed in section 2.

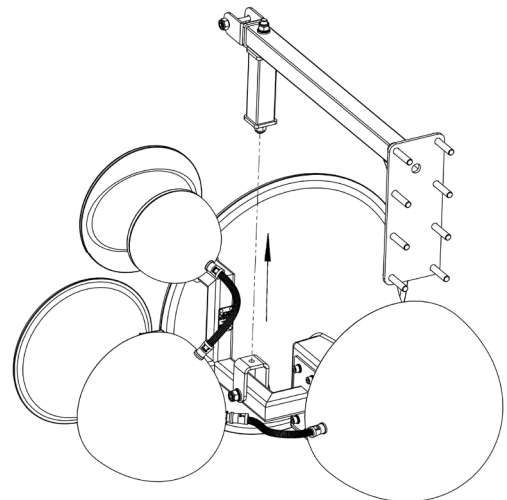

Figure 5.15: Air Motion lifting

5.4 Wall Mounting

Step 3:

Attach the U bracket to the extension piece with the M12 Aerotight nut using a 19 mm ratchet spanner.

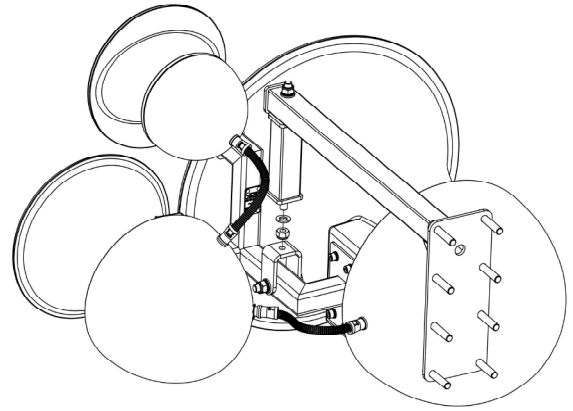

Figure 5.16: Air Motion wall mount

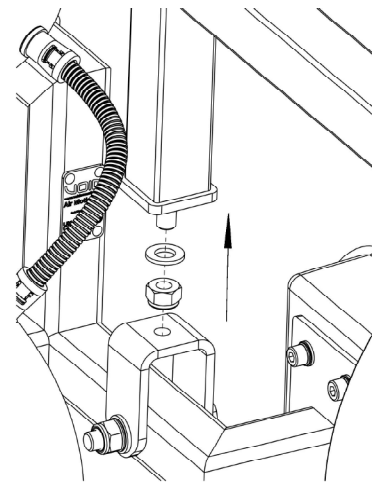

Figure 5.17: Air Motion wall mount detail

Step 4:

With the lifting equipment still in place, attach the secondary bond safety wire (not supplied) to the central box section. The safety wire should be attached to a secondary fixing point, close to where the bracket is fixed to the wall.

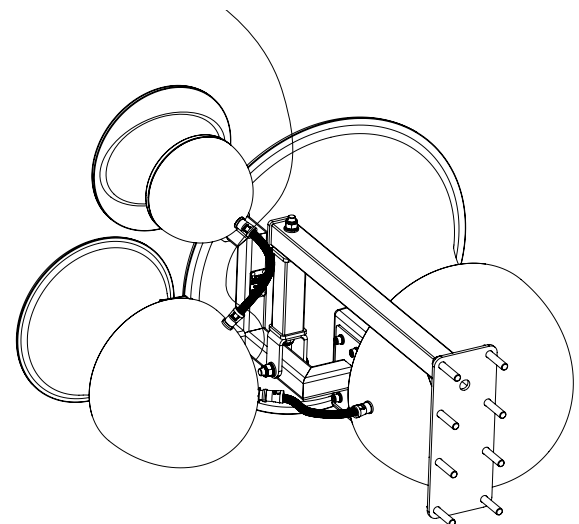

Figure 5.18: Safety wire attachment

5.5 Ceiling Mounting

Parts required:

TU - Multi Bracket (600mm)	White - IT1089
	Black - IT1088

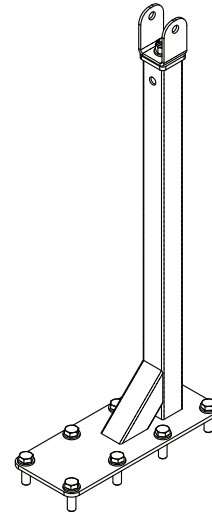

Figure 5.20: TU - Multi Bracket

Step 1:

Lift the Air Motion into position making sure to hold it by the safe lifting positions detailed in section 2.



All eight bolts must be fitted when securing the bracket to the ceiling.

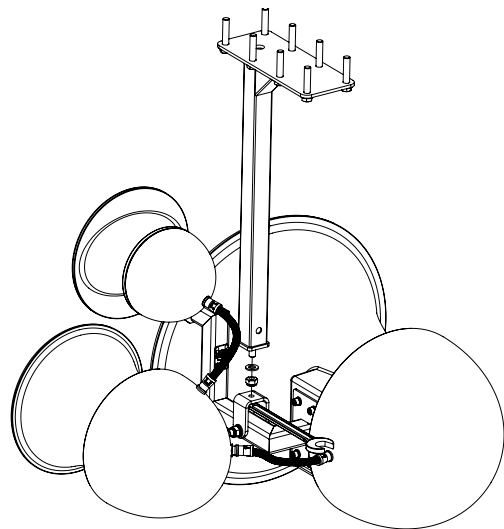

Figure 5.21: Air Motion ceiling mount

Step 2:

Attach the Air Motion to the bracket with the M12 Aerotight nut using a 19 mm ratchet spanner.

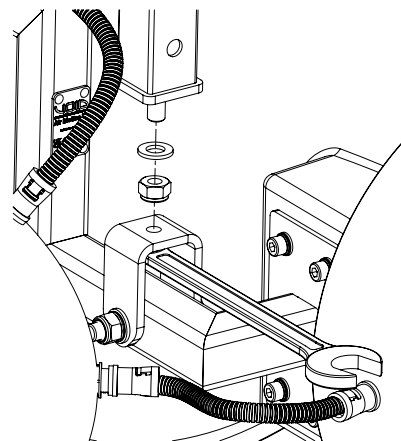

Figure 5.22: Air Motion ceiling mount detail

5.5 Ceiling Mounting

Step 4:

With the lifting equipment still in place, attach the secondary bond safety wire (not supplied) to the central box section. The safety wire should be attached to a secondary fixing point, close to where the bracket is fixed to the wall.

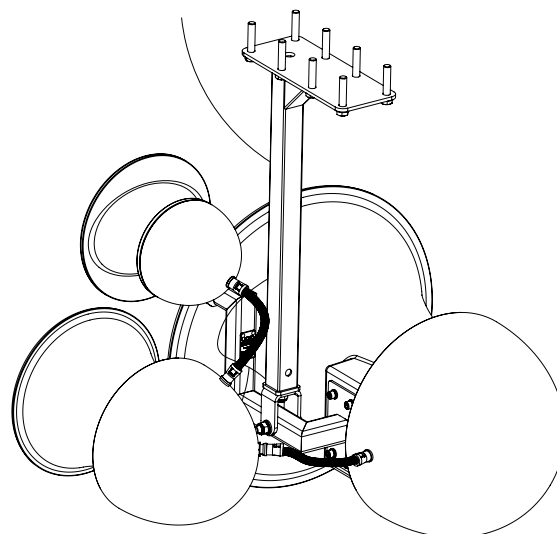

Figure 5.23: Safety wire attachment



The safety wire must be rated to 35.4 kg (78 lbs) with a safety factor conforming to local regulations.

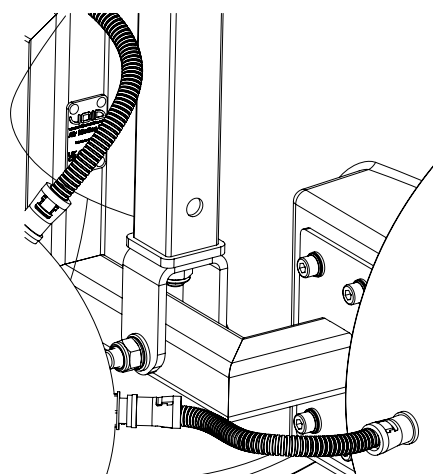

Figure 5.24: Safety wire attachment

5.6 Truss Mounting

Parts required:

TU - Truss Bracket	White - IT1082
	Black - IT1081

Step 1:

Remove the wing-nuts from the couplers and position the bracket in the desired location on the truss.

Step 2:

Tighten the wing-nuts on the couplers so that the bracket is securely fastened. Remove the M12 Aerotight nut using a 19 mm ratchet spanner.

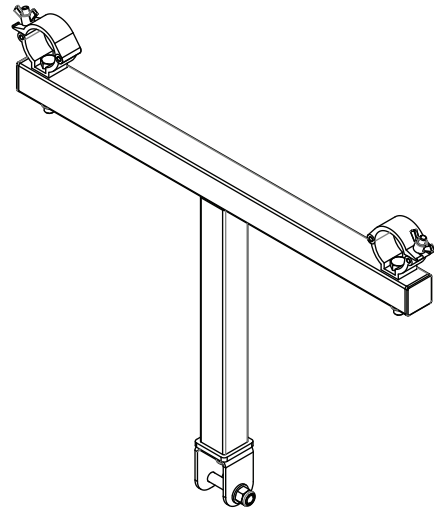

Figure 5.25: TU - Truss Bracket

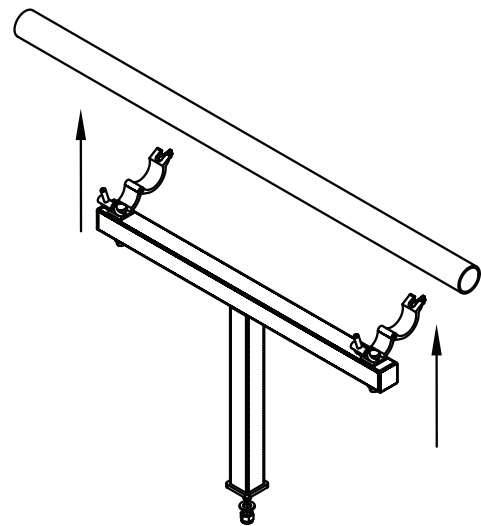

Figure 5.26: Positioning the truss bracket

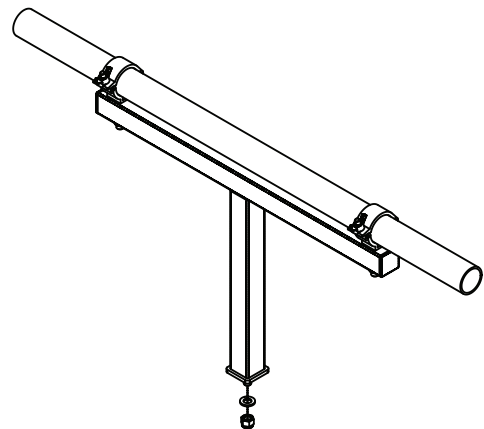

Figure 5.27: Attaching the truss bracket

5.6 Truss Mounting

Step 3:

Lift the Air Motion into position making sure to hold it by the safe lifting positions detailed in section 2.

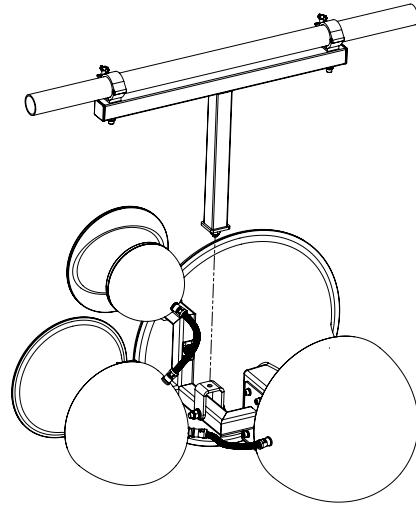

Figure 5.28: Air Motion truss mount

Step 4:

Attach the Air Motion the bracket with the M12 Aerotight nut using a 19 mm ratchet spanner.

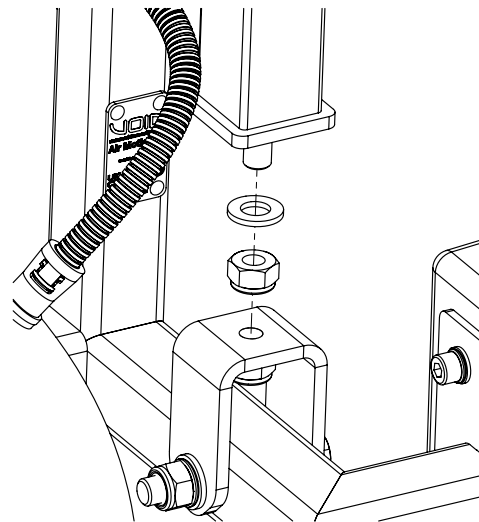

Figure 5.29: Air Motion truss mount detail

Step 5:

Attach the secondary bond (safety wire) to the central box section.



The safety wire must be rated to 35.4 kg (78 lbs) with a safety factor conforming to local regulations.

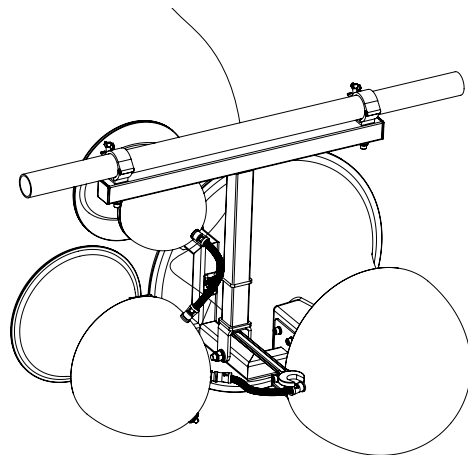

Figure 5.30: Safety wire attachment

5.7 Ceiling Pole Mounting

Parts required:

TU - Ceiling Bracket (1000mm)	White - IT3486
	Black - IT3485
TU - Ceiling Bracket (1500mm)	White - IT3149
	Black - IT2462
TU - Ceiling Bracket (500mm)	White - IT2817
	Black - IT2816

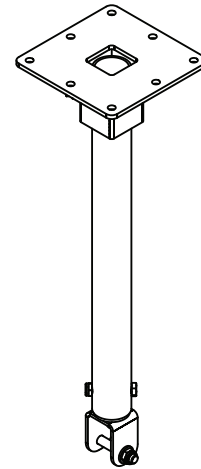

Figure 5.31: TU - Ceiling Bracket

Step 1:
Lift the Air Motion into position making sure to hold it by the safe lifting positions detailed in section 2.

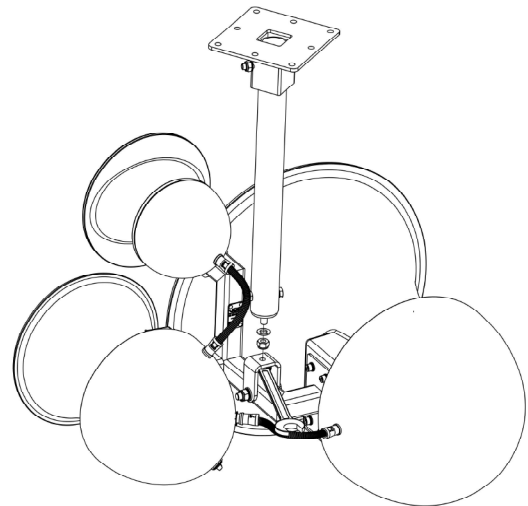

Figure 5.32: Air Motion positioning

Step 2:
Attach the Air Motion to the bracket with the M12 Aerotight nut using a 19 mm ratchet spanner.

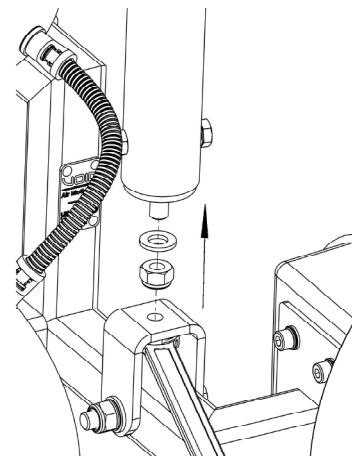

Figure 5.33: Attaching the Air Motion

5.7 Ceiling Pole Mounting

Step 3:

Attach the secondary bond (safety wire) to the central box section.



The safety wire must be rated to 35.4 kg (78 lbs) with a safety factor conforming to local regulations.

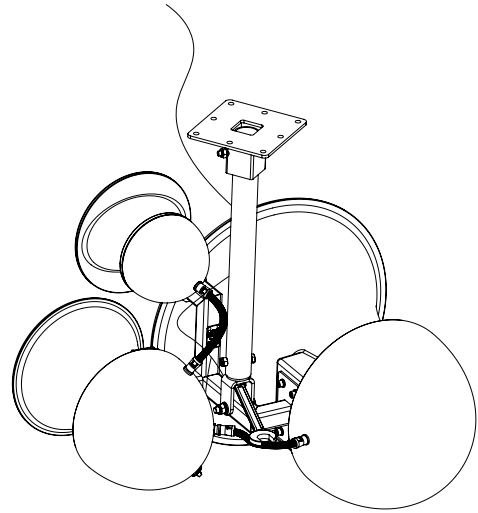

Figure 5.34: Safety wire attachment

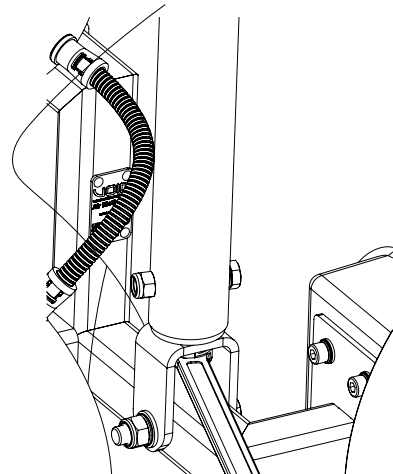

Figure 5.35: Safety wire detail

5.8 Pole Mounting

Parts required:

TU - Pole Bracket	White - IT3514
	Black - IT3513

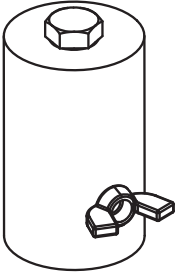

Figure 5.36: TU - Pole Bracket

Step 1:
Remove the M12 bolt from the pole mount bracket.

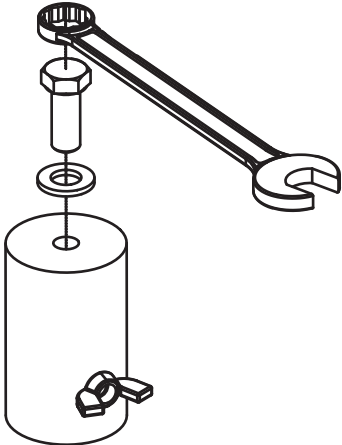

Figure 5.37: Pole mount bracket removal

Step 2:
Mount the pole mount bracket to the U bracket.

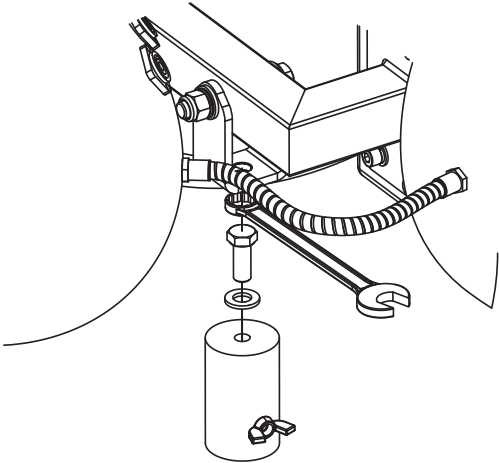

Figure 5.38: Mounting to the U bracket

5.8 Pole Mounting

Step 3:

Lift the Air Motion loudspeaker into position taking care to follow the safe handling positions detailed in section 2.

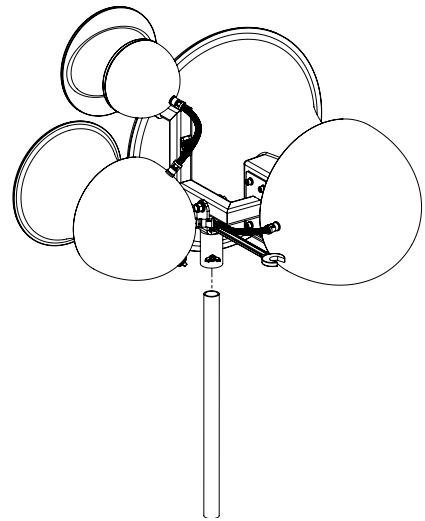

Figure 5.39: Positioning the loudspeaker

Step 4:

Adjust the loudspeaker into the desired position and then tighten the wing nut on the pole mount bracket.

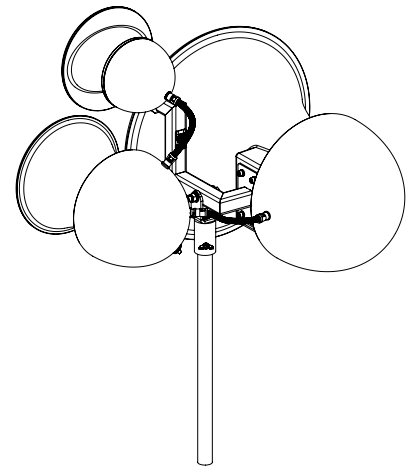

Figure 5.40: Adjusting the loudspeaker position

6 Service

Void Air Motion loudspeakers should only be serviced by a fully-trained technician.



No user serviceable parts inside. Refer servicing to your dealer.

6.1 Return authorisation

Before returning your faulty product for repair, please remember to get an R.A.N. (Return Authorisation Number) from the Void dealer who supplied the system to you. Your dealer will handle the necessary paperwork and repair. Failure to go through this return authorisation procedure could delay the repair of your product.

Note that your dealer will need to see a copy of your sales receipt as proof of purchase so please have this to hand when applying for return authorisation.

6.2 Shipping and packing considerations

- When sending a Void Air Motion loudspeaker to an authorised service centre, please write a detailed description of the fault and list any other equipment used in conjunction with the faulty product.
- Accessories will not be required. Do not send the instruction manual, cables or any other hardware unless your dealer asks you to.
- Pack your unit in the original factory packaging if possible. Include a note of the fault description with the product. Do not send it separately.
- Ensure safe transportation of your unit to the authorised service centre.

7 Appendix

7.1 Architectural specifications

The loudspeaker shall be an active, three-way, bi-amped system consisting of a high power 12" (305 mm) isometric conical horn loaded low frequency (LF) transducer with a passive two way, mid-high frequency section consisting of an 8" (200 mm) isometric conical horn loaded mid frequency (MF) transducer and a 1.5" (38.1 mm) diameter exit high frequency (HF) compression driver.

Low frequency (LF), mid and high frequency (MF and HF) transducers shall be enclosed in separate and independent moulded conical fibreglass cabinets with a smooth, high gloss finish of any RAL colour.

The LF and MF transducers shall be constructed on a cast aluminium frame, with a treated paper cone, 63.5 mm (4") for the LF and 50.8 mm (2") for the MF voice coil, wound with copper wires on a high quality voice coil former, for high power handling and long-term reliability. The HF transducer shall project its sound through an elliptic conical waveguide with a 200 mm (8") baffle diameter.

Performance specifications for a typical production unit shall be as follows: the usable on-axis bandwidth of 135 Hz to 20 kHz (-10 dB IEC 60268-5), with an average 50° directivity pattern on the vertical axis and 60° on the horizontal one (-6 dB down from on-axis level) from 1 kHz to 12 kHz; maximum SPL of 137 dB peak, measured at 1 m using IEC268-5 pink noise. Crossover points shall be at 140 Hz and 600 Hz for the LF section and 1.7 kHz passive for the MHF. The system shall be powered by its own dedicated power amplification module with DSP management, with the wiring connection via two 4-pin locking connector; one for input and one for link out to another speaker.

The aesthetically designed enclosures shall be bolted onto a powder-coated steel frame using a minimum of four M8 bolts per horn. This frame aligns the horns in the correct acoustic space to achieve a good directivity across the loudspeaker system's entire spectrum. The frame includes mounting holes for a "U" bracket fixture, compatible with both ceiling and wall mounting brackets. The external dimensions of the enclosures and frame shall be (W) 854 mm x (H) 672 mm x (D) 658 mm (33.6" x 26.5" x 25.9"). Weight shall be 35.4 kg (78 lbs).

The loudspeaker shall be the Void Acoustics Air Motion V2.

7 Appendix

7.2 Changelog

Document Version	Notes	Valid for S.N
UG10519-2.2	<p>Product diagrams, images, specs, updated product images & diagrams to reflect changes to the physical appearance made in the latest generation of Air Motion.</p> <p>Physical changes to Air Motion include:</p> <ul style="list-style-type: none">• HF driver updated with a protective chamber• Stainless grilles and internal bracket• Ingress proof conduit and glands• Hydrophobic coating on the drivers	A6MXXXX 2024 models - Current
UG10519-2.3	Updated specs to IEC 60268-5	A6MXXXX - Current

NORTH AMERICA

Void Acoustics North America

Call: +1 630 686 6616

Email: sales.usa@voidacoustics.com

HEAD OFFICE

Void Acoustics Research Ltd

Unit L, The Fulcrum

Vantage Way

Poole

BH12 4NU

United Kingdom

Call: +44(0) 1202 666006

Email: hello@voidacoustics.com



Hear. Feel. Connect.

voidacoustics.com