

VOID

Hear. Feel. Connect.

voidacoustics.com



Airten V3

Big impact, small footprint

USER GUIDE V2.2

©2026 Void Acoustics Research Ltd.

This user guide is subject to change without notice.
For the latest online version, visit: www.voidacoustics.com

Void Acoustics and the Void logo are registered trademarks of Void Acoustics Research Ltd. in the United Kingdom, USA and other countries; all other Void trademarks are the property of Void Acoustics Research Ltd.

Contents

1	Safety and regulations	4
1.1	Important safety instructions	4
1.2	Limitations	4
1.3	EC declaration of conformity	4
1.4	UKCA Conformity	4
1.5	Warranty Statement	4
1.6	WEEE directive	4
2	Unpacking and Checking	5
3	About	6
3.1	Welcome	6
3.2	Airten overview	6
3.3	Key features	6
3.4	Airten V3 specifications	7
3.5	Airten dimension	8
4	Cabling and wiring	9
4.1	Electrical safety	9
4.2	Cable considerations for fixed installations	9
4.3	Airten wiring diagram	9
4.4	Bias D1/Q1/Q2 Phoenix wiring	10
4.5	Bias Q3/Q5 4-pin locking connector wiring	10
5	Mounting	11
5.1	Installation safety	11
5.2	Airten pole mounting	12
5.3	Attaching the stud bracket	14
5.4	Airten wall mounting	16
5.6	Airten ceiling mounting	18
5.7	Pole mounting on U bracket	20
6	Service	22
6.1	Return authorisation	22
6.2	Shipping and packing considerations	22
7	Appendix	23
7.1	Architectural Specifications	23
7.2	Changelog	23

1 Safety and Regulations

1.1 Important safety instructions



The lightning flash with an arrowhead symbol within an equilateral triangle is intended to alert the user to the presence of uninsulated "dangerous voltage" within the product's enclosure that may be of sufficient magnitude to constitute a risk of electric shock to persons.



The exclamation point within an equilateral triangle is intended to alert the user of the presence of important operating and maintenance (servicing) instructions in the literature accompanying the appliance.

Safety instructions - read this first

1. Read these instructions.
2. Keep these instructions.
3. Heed all warnings.
4. Follow all instructions.
5. Do not use this apparatus near water.
6. Clean only with a dry cloth.
7. Do not block any ventilation openings. Install in accordance with the manufacturer's instructions.
8. Do not install near any heat source such as radiators, heat registers, stoves, or other such apparatus that produce heat.
9. Do not defeat the safety purpose of the grounding-type plug. A grounding type plug has two blades and a third grounding prong. The third prong is provided for your safety. If the provided plug does not fit into your outlet, consult an electrician for replacement of the obsolete outlet.
10. Protect power cords from being walked on or pinched particularly at plugs, convenience receptacles, and the point where they exit the apparatus.
11. Only use attachments and accessories specified by Void Acoustics.
12. Only use with the cart, stand, tripod, bracket, or table specified by the manufacturer, or sold with the apparatus. When a cart is used, use caution when moving the cart/apparatus combination to avoid injury from tip-over.
13. Unplug the apparatus during lightning storms or when unused for long periods of time.
14. Refer all servicing to qualified service personnel. Servicing is required when the apparatus has been damaged in any way, such as when the power-supply cord or plug is damaged, liquid has been spilled or objects have fallen into the apparatus, the apparatus has been exposed to rain or moisture, does not operate normally, or has been dropped.
15. Since the mains power supply cord attachment plug is used to disconnect the device, the plug should always be easily accessible.
16. Void loudspeakers can produce sound levels capable of causing permanent hearing damage from prolonged exposure. The higher the sound level, the less exposure needed to cause such damage. Avoid prolonged exposure to the high sound levels from the loudspeaker.

1.2 Limitations

This guide is provided to help familiarise the user with the loudspeaker system and its accessories. It is not intended to provide comprehensive electrical, fire, mechanical and noise training and is not a substitute for industry-approved training. Nor does this guide absolve the user of their obligation to comply with all relevant safety legislation and codes of practice. While every care has been taken in creating this guide, safety is user-dependent and Void Acoustics Research Ltd cannot guarantee complete safety whenever the system is rigged and operated.

1.3 EC declaration of conformity

For EC Declaration of Conformity please go to:

www.voidacoustics.com/eu-declaration-loudspeakers

1.4 UKCA marking

For details of the UKCA marking go to:

www.voidacoustics.com/uk-declaration-loudspeakers

1.5 Warranty statement

For warranty statement go to:

<https://voidacoustics.com/terms-conditions/>

1.6 WEEE directive

If the time arises to throw away your product, please recycle all the components possible.



This symbol indicates that when the end-user wishes to discard this product, it must be sent to separate collection facilities for recovery and recycling. By separating this product from other household-type waste, the volume of waste sent to incinerators or land-fills will be reduced and natural resources will thus be conserved.

The Waste Electrical and Electronic Equipment Directive (WEEE Directive) aims to minimise the impact of electrical and electronic goods on the environment. Void Acoustics Research Ltd complies with the Directive 2002/96/EC and 2003/108/EC of the European Parliament on waste electrical and electronic equipment (WEEE) in order to reduce the amount of WEEE that is being disposed of in land-fill sites. All of our products are marked with the WEEE symbol; this indicates that this product must NOT be disposed of with other waste. Instead it is the user's responsibility to dispose of their waste electrical and electronic equipment by handing it over to an approved reprocessor, or by returning it to Void Acoustics Research Ltd for reprocessing. For more information about where you can send your waste equipment for recycling, please contact Void Acoustics Research Ltd or one of your local distributors.



2 Unpacking and Checking

All Void Acoustics products are carefully manufactured and thoroughly tested before being despatched. Your dealer will ensure that your Void products are in pristine condition before being forwarded to you but mistakes and accidents can happen.

Before signing for your delivery:

- Inspect your shipment for any signs of contamination, abuse or transit damage as soon as you receive it
- Check your Void Acoustics delivery fully against your order
- If your shipment is incomplete or any of its contents are found to be damaged; inform the shipping company and inform your dealer.

Airten V3 loudspeakers are heavy (20 kg/44.1 lbs) and require a minimum two people to lift.

- Airten V3 loudspeakers come double boxed and are stapled shut; take care when unboxing and removing the staples to avoid injury or damage to the loudspeaker
- If you need to place the loudspeaker on a flat surface ensure you use a lint free product to protect the finish
- When you have removed the Airten V3 loudspeaker from the packaging inspect it to ensure there is no damage and keep all original packaging in case it needs to be returned for any reason.

See section 1.5 for registration and warranty conditions and see section 6 if your product needs service.

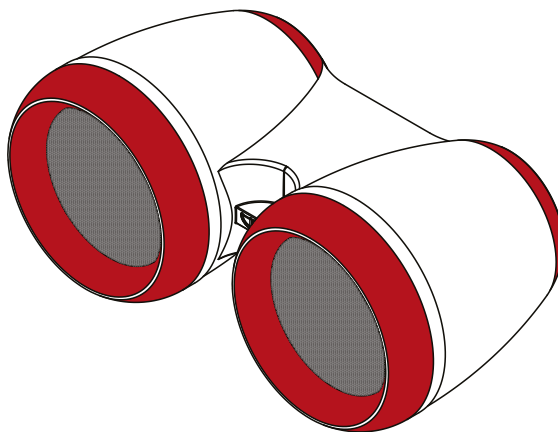

Figure 2.1: Safe handling positions
(Indicated in red)

3 About

3.1 Welcome

Many thanks for purchasing this Void Acoustics Airten V3. We truly appreciate your support. At Void, we design, manufacture and distribute advanced professional audio systems for the installed and live sound market sectors. Like all Void products, our highly skilled and experienced engineers have successfully combined pioneering technologies with ground-breaking design aesthetics, to bring you superior sound quality and visual innovation. In buying this product, you are now part of the Void family and we hope using it brings you years of satisfaction. This guide will help you both use this product safely and ensure it performs to its full capability.

3.2 Airten overview

This small, futuristic-styled composite loudspeaker is particularly favoured for high-end club and bar applications. Enjoy exceptional fidelity, very low resonance and accurately controlled dispersion.

Three key enhancements have been made in this latest V3 model to improve performance. The new crossover provides better frequency linearity, coherence and summation between the drivers. By introducing the Finite Element Analysis (FEA) optimised rear port, with refined aesthetics, noise and distortion are reduced while airflow is increased to reduce power compression. In addition, the diaphragm size within the compression driver has increased from 44 mm to 63 mm, allowing each driver to operate at its optimal frequency band with more efficiency and more accurate high frequency detail.

3.3 Key features

- Compact high-output dual 10 inch loudspeaker
- Small footprint ideal for DJ monitoring
- Cabinet geometry optimised for minimal resonance
- 80°H x 70°V dispersion pattern
- Space saving coaxial MF/HF driver
- Low-resonance fibreglass composite construction
- Extended response, with rear reflex loading
- T75-style fixing points for compatibility with a wide range of mounting options
- Available as standard in red with a black grille, black with a black grille, and white with a white grille. Custom RAL and KROME finishes are available upon request

3 About

3.4 Airten V3 specifications

Frequency Response ¹	80 Hz - 20 kHz
Maximum output ²	125 dB cont, 131 dB peak
Nominal Dispersion	80°H x 70°V
Sensitivity ³	99 dB 1W/1m
Driver configuration	2 x 10" LF, 1 x 1.3" exit HF compression driver
Power handling	500 W AES
Crossover points	Passive 1.2 kHz
Nominal impedance	4 Ω
Suggested Minimum Amplifier	Bias Q1.5+
Weight	20 kg (44.1 lbs)
Connections	2 x 4-pin locking connector
Enclosure	Fibreglass composite
Finish	Smooth cellulose
Height	303 mm (11.9")
Width	681 mm (26.8")
Depth	366 mm (14.4")
Mounting	Integral mounting plate
Colour	Custom colours available upon request

1 -10 dB IEC 60268-5 2 Calculated 3 Measured in half space

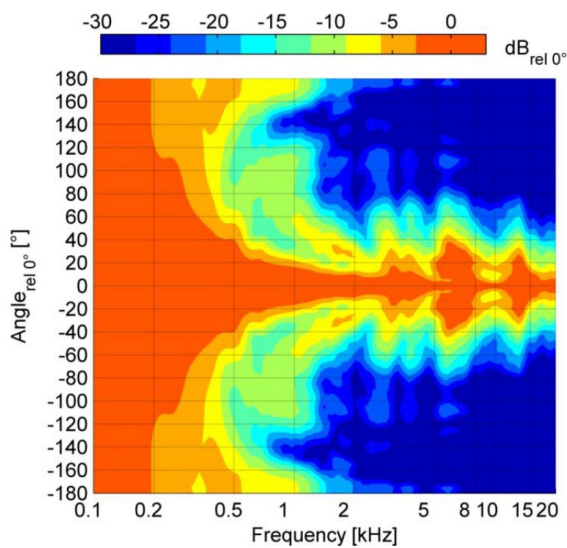

Figure 3.1: Horizontal directivity isobars

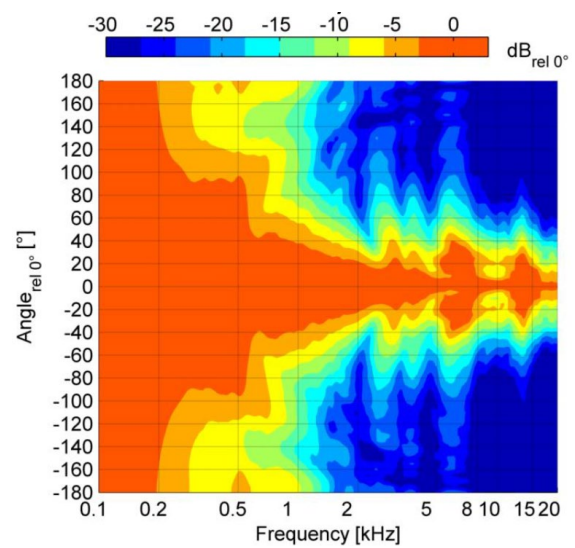

Figure 3.2: Vertical directivity isobars

3 About

3.5 Airten V3 dimensions

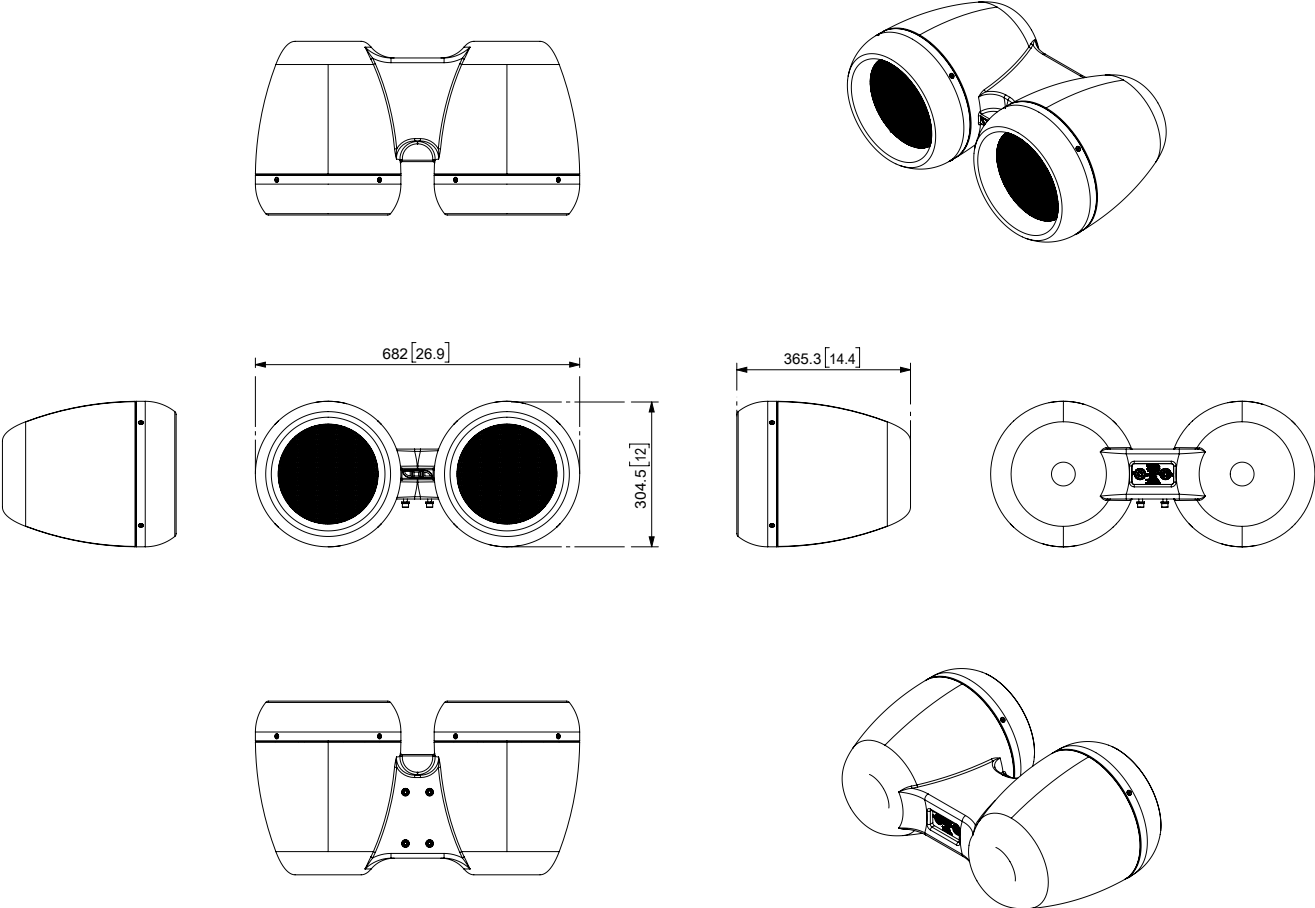

Figure 3.3: Dimensions

4 Cable and Wiring

4.1 Electrical safety



To avoid electrical hazards please note the following:

- Do not access the inside of any electrical equipment. Refer servicing to Void-approved service agents

4.2 Cable considerations for fixed installations

We recommend specifying installation-grade Low Smoke Zero Halogen (LSZH) cables for permanent installations. Cables for permanent installations should be compliant with the following standards:

- IEC 60332.1 Fire retardancy of a single cable
- IEC 60332.3C Fire retardancy of bunched cables
- IEC 60754.1 Amount of Halogen Gas Emissions
- IEC 60754.2 Degree of acidity of released gases
- IEC 61034.2 Measurement of smoke density

We suggest using the following maximum copper cable lengths to keep level losses below 0.6 dB.

Metric mm ²	Imperial AWG	8 Ω load	4 Ω load	2 Ω load
2.50 mm ²	13 AWG	36 m	18 m	9 m
4.00 mm ²	11 AWG	60 m	30 m	15 m

4.3 Airten V3 wiring diagram

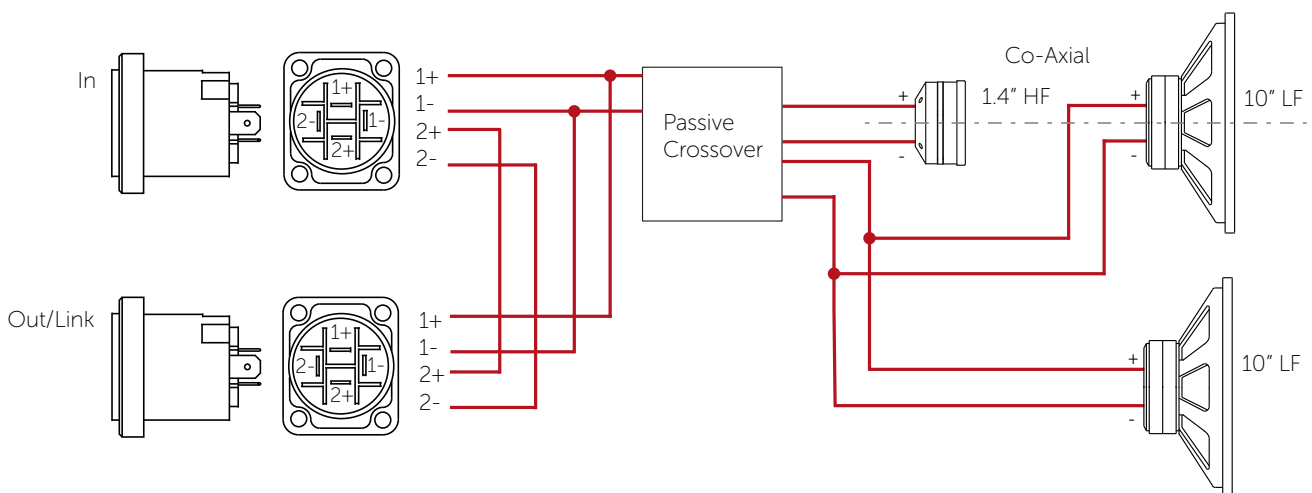

Figure 4.1: Airten V3 wiring diagram

	4-pin locking connector pins 1+/1-	4-pin locking connector pins 2+/2-
In	HF (1.4") and LF (2 x 10")	Link/out
Out	Link/out	Link/out

4 Cable and Wiring

4.4 Bias D1/Q1/Q2 Phoenix wiring

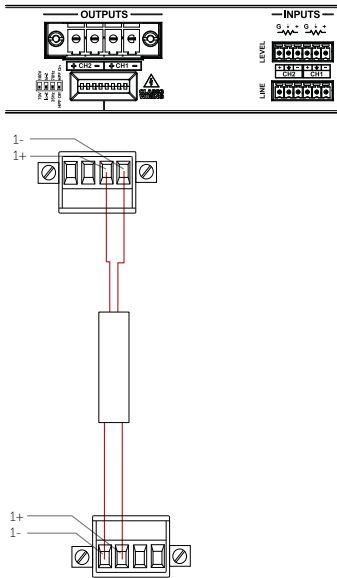

Figure 4.2: Bias D1

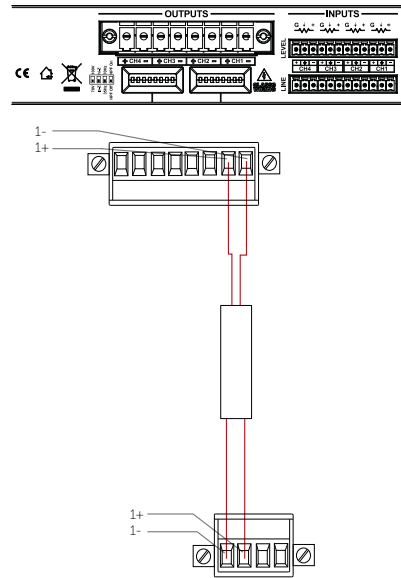

Figure 4.3: Bias Q1/Q2

Bias D1/Q1/Q2	Output 1 or 2
Output	LF (2 x 10") and HF (1.4")
Max parallel units	2 (2 Ω load to amplifier)

4.5 Bias Q3/Q5 4-pin locking connector wiring

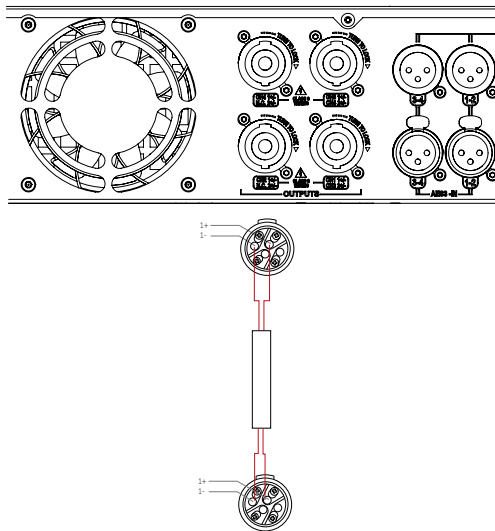

Figure 4.4: Bias Q3

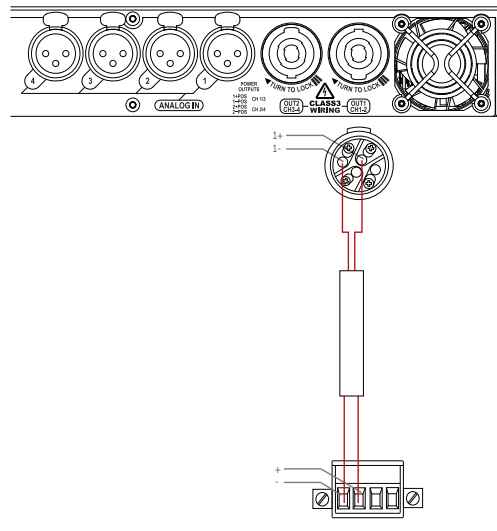

Figure 4.5: Bias Q5

Bias Q3/Q5	Output 1
Output	LF (2 x 10") and HF (1.4")
Max quantity per channel	2 (2 Ω load to amplifier)

5 Mounting

Tools Required

- 6 mm Allen key
- 19 mm ratchet spanner/wrench
- 17 mm ratchet spanner/wrench

5.1 Installation safety



To avoid mechanical hazards, please note the following:

- Safety regulations vary in different regions. Full compliance with those regulations must be your priority
- Installations must only be undertaken by fully qualified and experienced engineers/technicians who understand local regulations
- This may include consulting a structural engineer before installation of wall brackets
- Remember that all personnel have a duty of care to themselves, to their assistants, to the venue staff and to the public
- Before lifting any part of the system above head height, check the whole rig for loose tools or other items that may fall and cause injury
- Do not use a telephone (even if hands-free) whilst installing. Always concentrate fully on the installation operation
- Do not install equipment that is worn, damaged, corroded, mishandled or over-stressed in any way
- Use only Void-approved mounting equipment and accessories
- Secondary safeties should be provided in all instances where cabinets are flying or fixing overhead and should conform to local regulations

5.2 Pole Mounting

Parts required:

T75 Pole Bracket	White - IT1102
	Black - IT1099

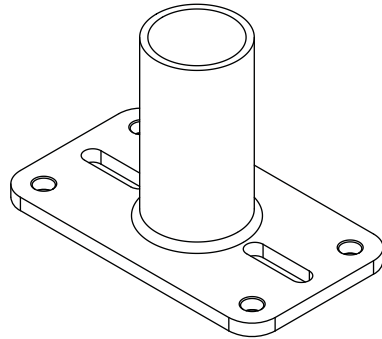

Figure 5.1: T75 Pole Bracket

Step 1:

Lay a soft lint free rug clear of debris on the ground to avoid damage to the loudspeaker. Place the Airten with the grilles face down and remove all four M8 bolts.

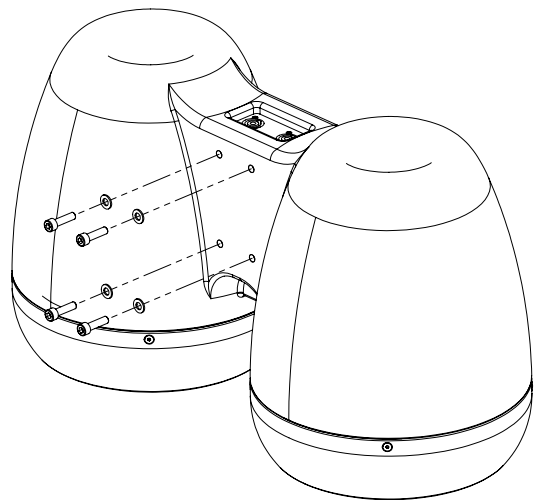

Figure 5.2: M8 socket cap removal

Step 2:

Place the T75 Pole Bracket into position and insert the M8 bolts.

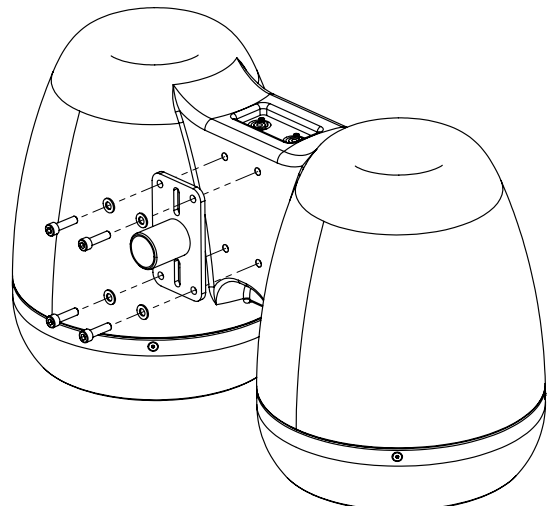

Figure 5.3: T75 pole bracket positioning

5.2 Pole Mounting

Step 3:

Fix all four M8 bolts taking care not to over tighten.

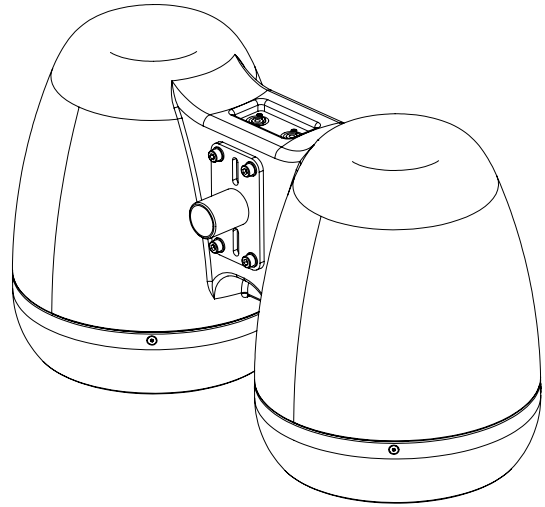

Figure 5.4: T75 pole bracket fixing

Step 4:

After erecting the pole use two people to lift the Airten loudspeaker into position taking care to use the safe handling positions in section 3.

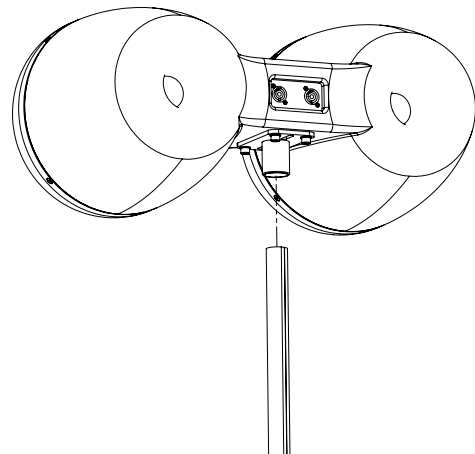

Figure 5.5: T75 pole mount positioning

Step 5:

Finally ensure that the Airten loudspeaker is safely in place by tightening the wingnut.

Maximum vertical rotation: 0°

Maximum horizontal rotation: 360°

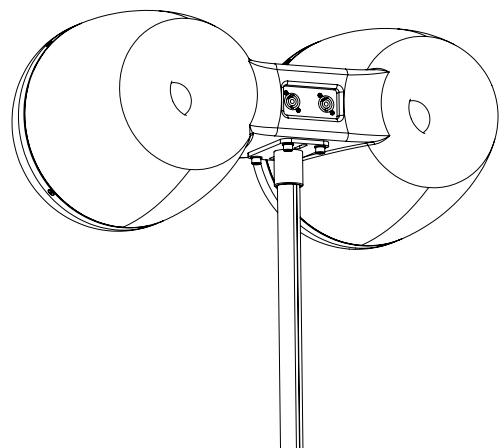

Figure 5.6: T75 pole mount

5.3 Attaching the Stud Bracket

Parts required:

T75 - Stud Bracket	White - IT1126
	Black - IT1125

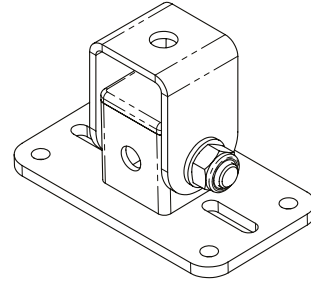

Figure 5.7: T75 - Stud Bracket

Step 1:

Lay a soft lint free rug clear of debris on the ground to avoid damage to the loudspeaker. Place the Airten with the horns face down and remove all four M8 bolts.

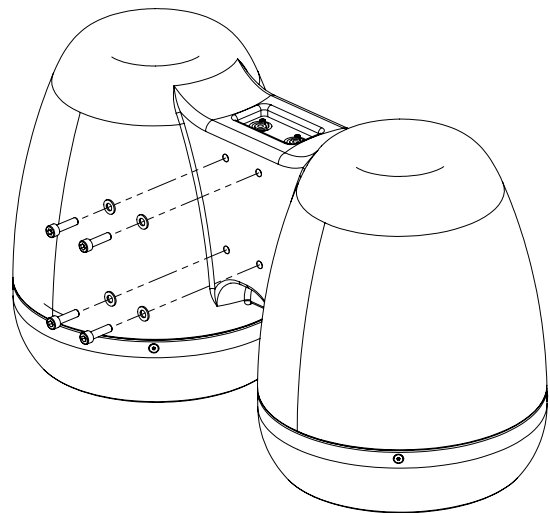

Figure 5.8: M8 socket cap removal

Step 2:

Place the T75 - Stud Bracket into position and insert the M8 bolts.

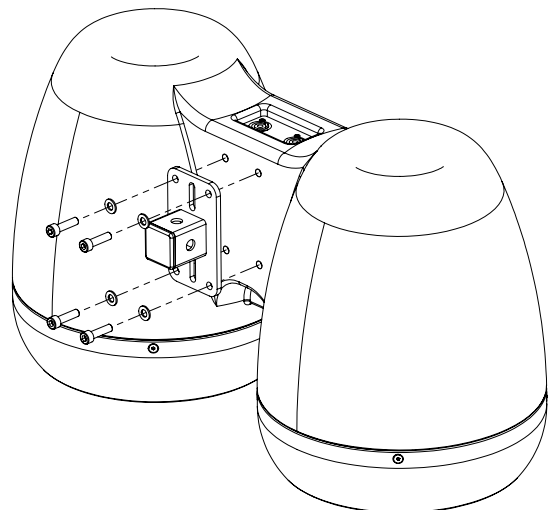

Figure 5.9: T75 - Stud Bracket positioning

5.3 Attaching the Stud Bracket

Step 3:

Fix all four M8 bolts taking care not to over tighten.

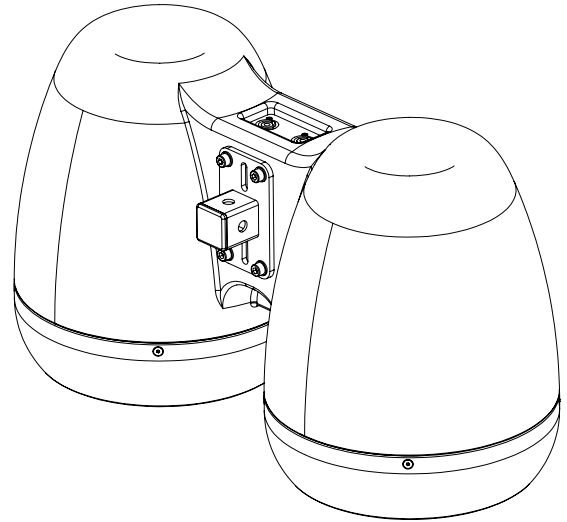

Figure 5.10:T75 - Stud Bracket fixing

Step 4:

Attach the TU - Stud Bracket.



Note:

The bracket is threaded for the bolt on one side only. Insert the M12 x 70 mm bolt through the non-threaded side and tighten. Then tighten the M12 nut.

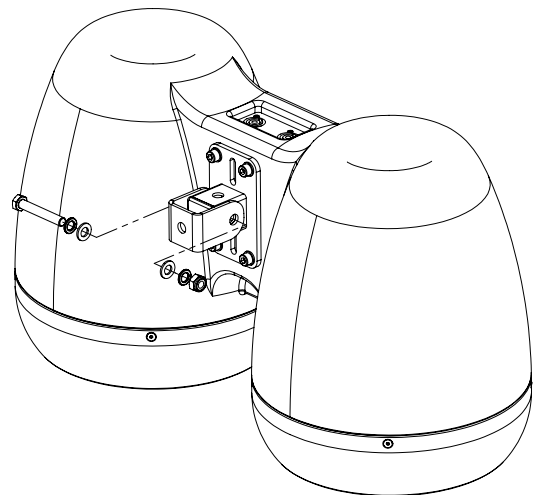

Figure 5.11: T75 - Stud Bracket U bracket fixing

5.4 Airten Wall Mounting

Parts required:

T75 - Wall Bracket	White - IT1133
	Black - IT1132



Note:
All bolts must be fitted when securing the bracket to the wall.

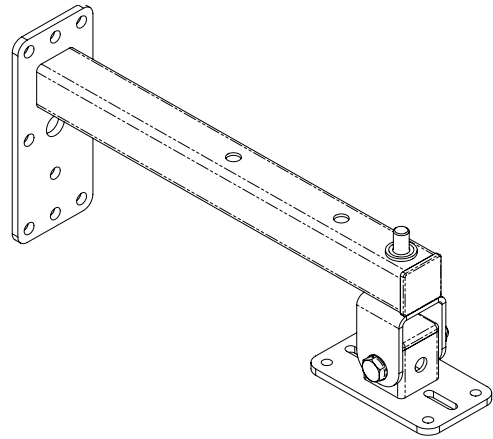

Figure 5.12: T75 - Wall Bracket

Step 1:
Attach the T75 bracket and TU bracket as shown in section 5.3. Lift the Airten loudspeaker into place using two people and the safe handling positions indicated in section 3.

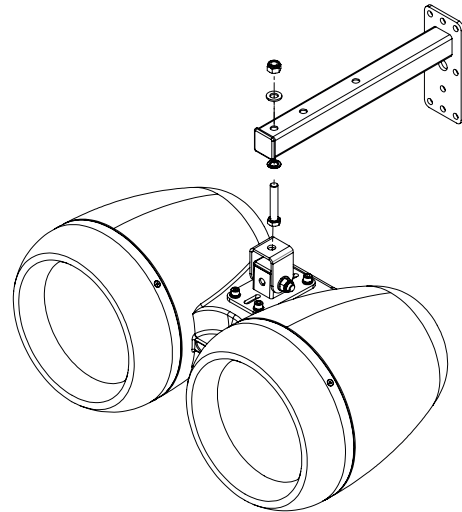

Figure 5.13: Airten loudspeaker positioning

Step 2:
With the Airten in position attach the M10 bolt above but do not tighten.

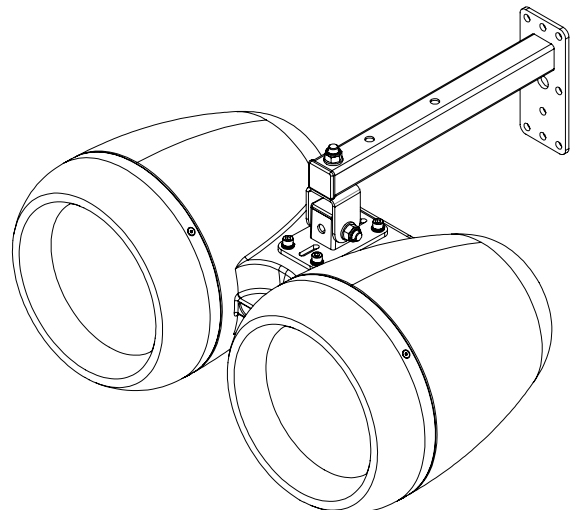

Figure 5.14: Airten loudspeaker fixing

5.4 Airten Wall Mounting Over Bracket

Step 3:

Rotate the Airten loudspeaker into the desired position and fully tighten the M10 bolt.

Maximum vertical rotation: 55°

Maximum horizontal rotation: 85°

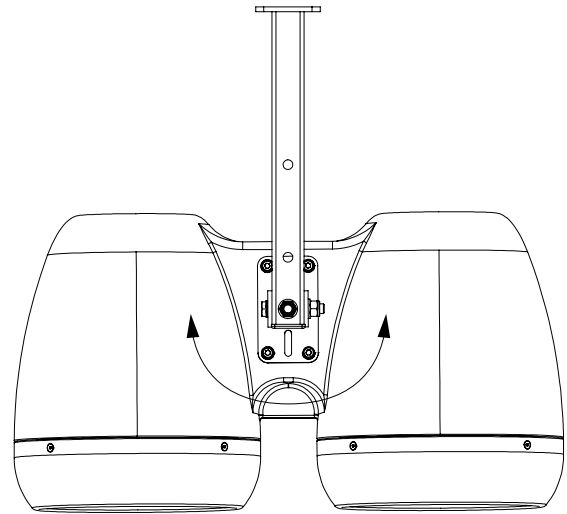

Figure 5.15: Airten loudspeaker positioning

Step 4:

Attach the secondary bond (safety wire) to the central box section.



The safety wire must be rated to 20 kg with a safety factor conforming to local regulations.

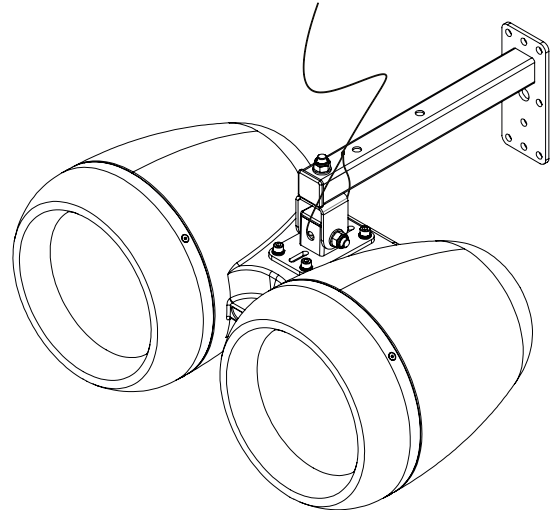

Figure 5.16: Safety wire attachment

5.5 Ceiling Pole Mounting

Parts required:

T75 - Ceiling Bracket (500 mm)	White - IT1905
	Black - IT1140
T75 - Ceiling Bracket (1000 mm)	White - IT3218
	Black - IT3217
T75 - Ceiling Bracket (1500 mm)	Black - IT3688



Note:

All eight bolts must be fitted when securing the bracket. Pole can be cut to length on site to accommodate installation requirements.

Step 1:

Remove the T75 plate from the ceiling bracket and fix it to the cabinet using all M8 bolts and washers.

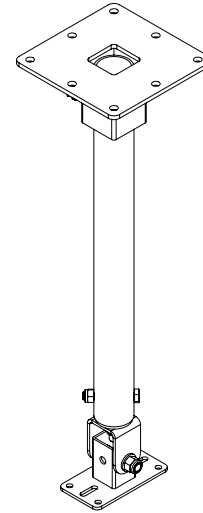

Figure 5.17: T75 - Ceiling Bracket

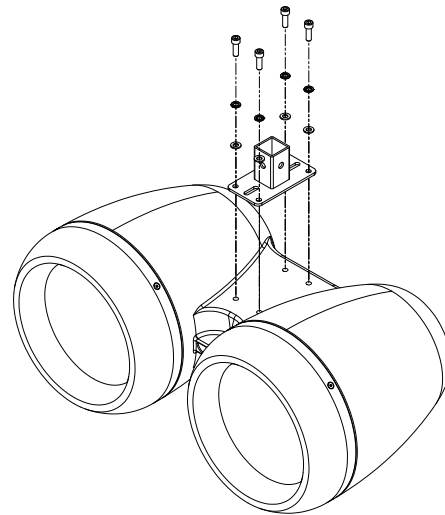

Figure 5.18: T75 attachment

Step 2:

Attach the Airten bracket with the M12 nut and bolt using a 19 mm ratchet spanner.



Note:

The bracket is threaded for the bolt on one side only. Insert the M12 x 70 mm bolt through the non-threaded side and tighten. Then tighten the M12 nut.

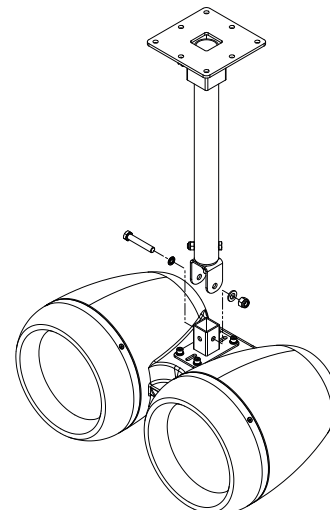

Figure 5.19: Airten positioning

5.5 Ceiling Pole Mounting

Step 3:

Attach the secondary bond (safety wire) to the central box section.



The safety wire must be rated to 20 kg with a safety factor conforming to local regulations.

Max horizontal rotation: 360°

Max vertical rotation: 90°

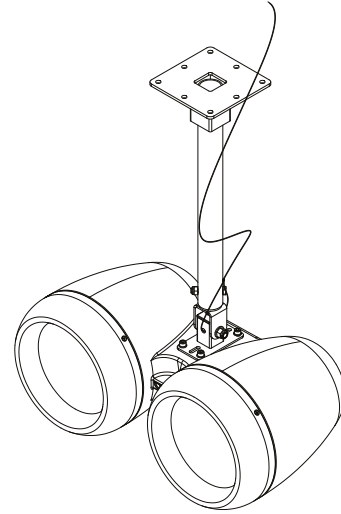

Figure 5.20: Safety wire attachment

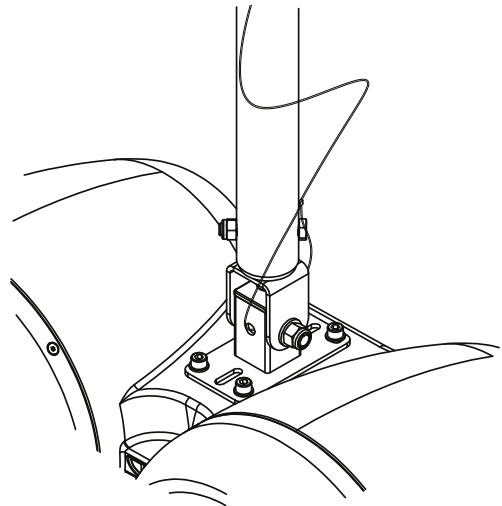

Figure 5.21: Safety wire attachment detail

5.6 Pole Mounting with Vertical Adjustment

Parts required:

Pole Mount Sleeve	White - IT2237
	Black - IT2238
T75 - Stud Bracket	White - IT1126
	Black - IT1125

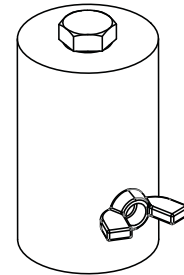

Figure 5.22: Pole mount sleeve

Step 1:
Remove the M12 bolt from the pole mount sleeve.

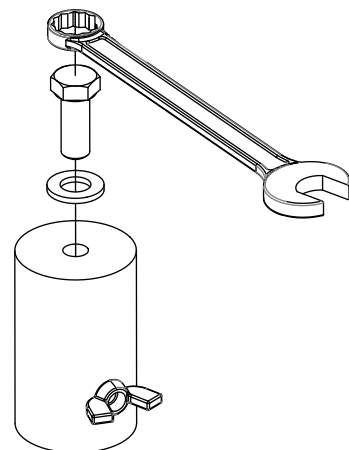

Figure 5.22: Pole mount bracket removal

Step 2:
Remove the U bracket from the T75 stud bracket.

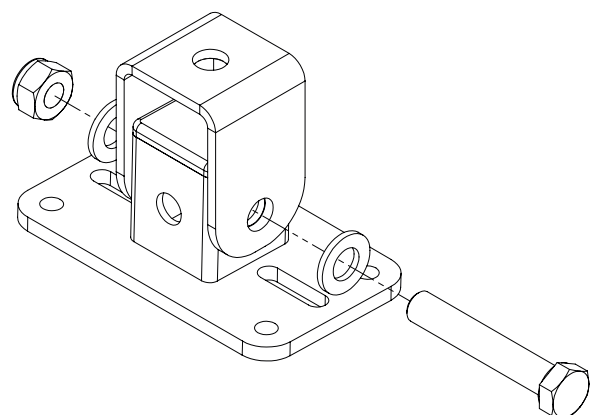

Figure 5.23: Remove U bracket

5.6 Pole Mounting with Vertical Adjustment

Step 3:

Attach the U bracket to the pole mount sleeve using the M12 bolt that was removed in step 1.

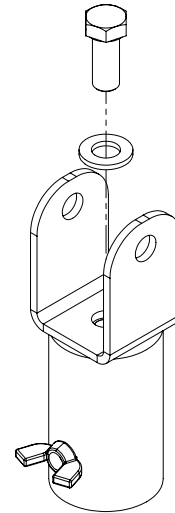

Figure 5.24: Attach U bracket

Step 4:

Attach the T75 bracket to the assembly using the M12 bolt removed in step 2.



Note:

The bracket is threaded for the bolt on one side only. Insert the M12 x 70 mm bolt through the non-threaded side and tighten. Then tighten the M12 nut.

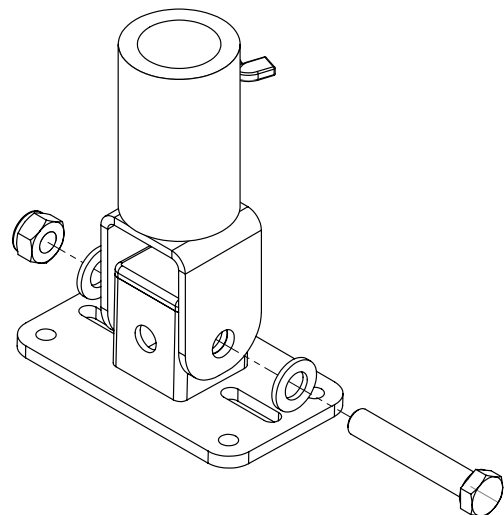

Figure 5.25: Remove U bracket

Step 5:

Attach the T75 bracket to the loudspeaker with all four M8 bolts and washers.

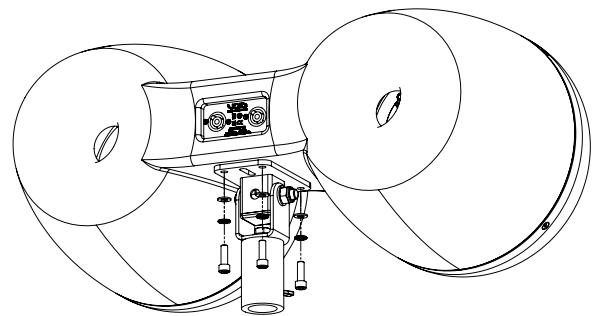

Figure 5.26: Attaching the bracket

Step 6:

Lift the loudspeaker into position taking care to follow the safe handling positions detailed in section 2.

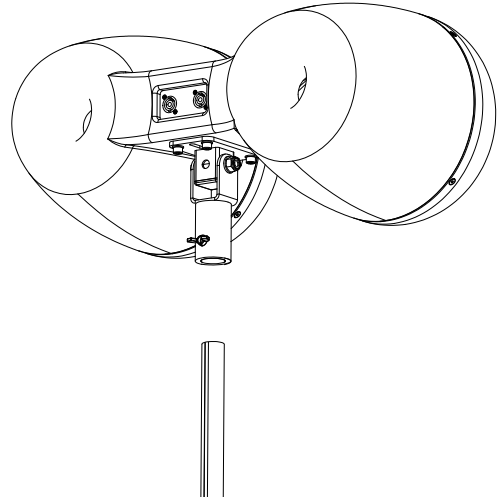

Figure 5.27: Adjusting the loudspeaker position

Step 7:

Adjust the loudspeaker into the desired position and then tighten the wing nut on the pole mount bracket.

Max horizontal rotation: 360°

Max vertical rotation: 90°

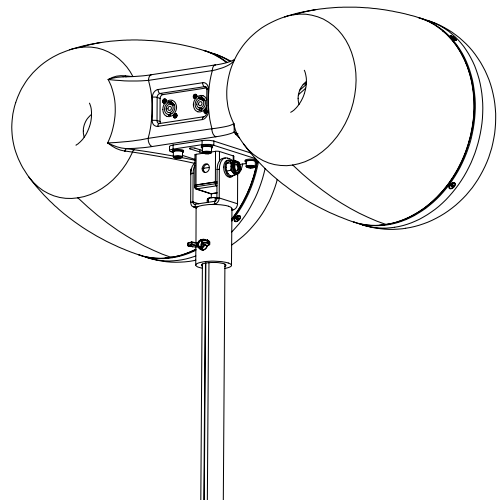

Figure 5.28: Adjusting the loudspeaker position

6 Service

Void Airten loudspeakers should only be serviced by a fully-trained technician.



No user serviceable parts inside. Refer servicing to your dealer.

6.1 Return authorisation

Before returning your faulty product for repair, please remember to get an R.A.N. (Return Authorisation Number) from the Void dealer who supplied the system to you. Your dealer will handle the necessary paperwork and repair. Failure to go through this return authorisation procedure could delay the repair of your product.

Note that your dealer will need to see a copy of your sales receipt as proof of purchase so please have this to hand when applying for return authorisation.

6.2 Shipping and packing considerations

- When sending a Void Airten loudspeaker to an authorised service centre, please write a detailed description of the fault and list any other equipment used in conjunction with the faulty product.
- Accessories will not be required. Do not send the instruction manual, cables or any other hardware unless your dealer asks you to.
- Pack your unit in the original factory packaging if possible. Include a note of the fault description with the product. Do not send it separately.
- Ensure safe transportation of your unit to the authorised service centre.

7 Appendix

7.1 Architectural specifications

The loudspeaker shall be a passive two-way system, consisting of two high power 10" (250 mm) direct radiating reflex loaded low frequency (LF) transducers, and 1.3" (35.6 mm) diameter co-axial direct radiating reflex loaded high frequency (HF) transducer, mounted in an aesthetically designed enclosure.

The co-axial transducer shall be constructed on a cast aluminium frame, with the low frequency transducer consisting of a polycarbonate LF cone with its dust cap removed and a 64 mm (2.5") diameter voice coil, wound with copper wire on a high quality voice coil former, for high power handling and long-term reliability. The high frequency transducer shall be bolted through the rear of the magnet structure that belongs to the low frequency transducer to form a co-axial drive unit. The sound shall project through a machined waveguide that exits in the centre of the low frequency transducer and uses the 250 mm (10") baffle diameter to achieve pattern control and low distortion.

Power handling shall be at 500 W AES at a rated impedance of 4 Ω ; and crossover point at 1.2 kHz using 2nd order filters (12 dB per octave). The system shall be powered by its own dedicated power amplification module with DSP management, with the wiring connection via two 4-pin locking connector (one for input and one for link-out to another speaker), to allow for pre-wiring of the connector before installation.

Performance specifications for a typical production unit shall be as follows: a usable on-axis bandwidth of 80 Hz to 20 kHz (-10 dB IEC 60268-5), with an average 70° directivity pattern in the vertical axis and 80° in the horizontal one (-6 dB down from on-axis level) from 1 kHz to 10 kHz; maximum SPL of 131 dB peak measured at 1m using IEC268-5 pink noise;

The enclosure shall be moulded fibreglass reinforced plastic construction, with a smooth cellulose finish of any RAL colour, and shall include integral threaded inserts for the fitment of wall and ceiling mounting hardware. The external dimensions shall be (H) 303 mm x (W) 681 mm x (D) 366 mm (11.9" x 26.8" x 14.4"). Weight shall be 20 kg (44.1 lbs).

The loudspeaker shall be the Void Acoustics Airten V3.

7.2 Changelog

Document Version	Notes	Valid for S.N
UG10517-2.2	Updated specs to IEC 60268-5	A6TXXXX - Current

7 Appendix

Accessories

IT3340 - Airten V3 Flightcase (holds two)



NORTH AMERICA

Void Acoustics North America

Call: +1 (630) 686 6616

Email: sales.usa@voidacoustics.com

HEAD OFFICE

Void Acoustics Research Ltd

Unit L, The Fulcrum

Vantage Way

Poole

BH12 4NU

United Kingdom

Call: +44(0) 1202 666006

Email: hello@voidacoustics.com



Hear. Feel. Connect.

voidacoustics.com